

Mounting Bases and Vibration Isolation for Greenheck Centrifugal Fans

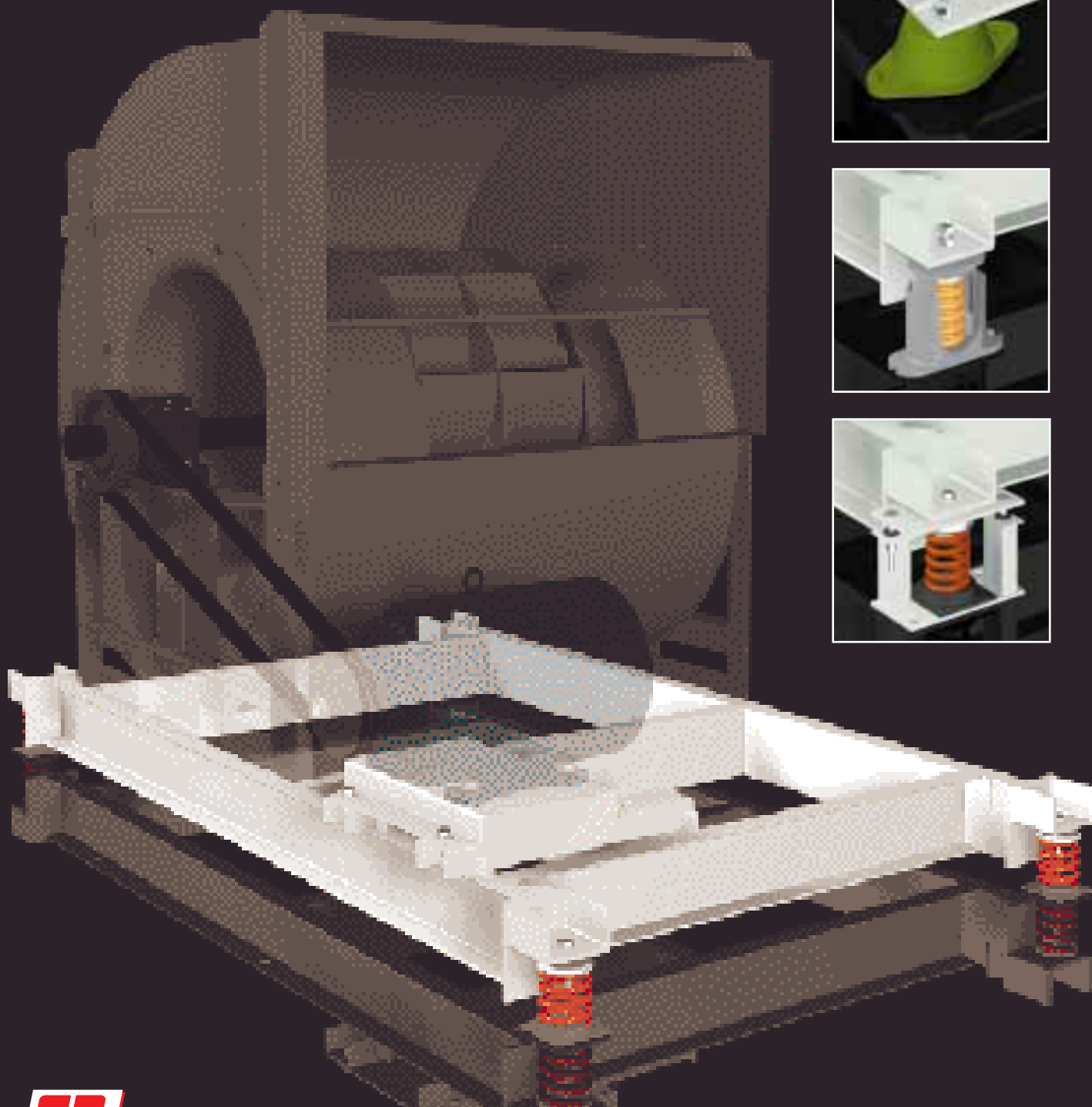

 **GREENHECK**

MOUNTING BASES AND VIBRATION ISOLATION

for Greenheck Centrifugal Fans

This catalog outlines the types of bases and isolators as offered by Greenheck for use with both utility and centrifugal fans. The use of isolation equipment is more important than ever when considering the trends towards lighter construction of modern buildings and the increasing use of mechanical equipment. In addition, the fact that building owners and occupants are more sensitive to vibration-related problems makes proper selection and installation of isolation equipment extremely important.

The advantages of buying fan and isolation equipment directly from Greenheck include proper selection and identification of isolators, assembled fan and base packages, final vibration testing and trim balancing of the fan on the isolation base.

Included in this catalog are easy to use selection guides and typical specifications. For more complete selection criteria, refer to the latest ASHRAE Handbook, HVAC Applications - Sound and Vibration Control.

Table of Contents

Benefits of Greenheck Supplied Bases	3
Mounting Options	4
Isolator Options	5
Mounting Selection Guide	6
Isolator Selection Guide	7
Specification Checklist	8

Shown below are typical examples of different isolation equipment used with centrifugal fans.

Utility fans are typically mounted on mounting rails incorporating either neoprene or spring mounts. (Fan shown is Model SWB-30)

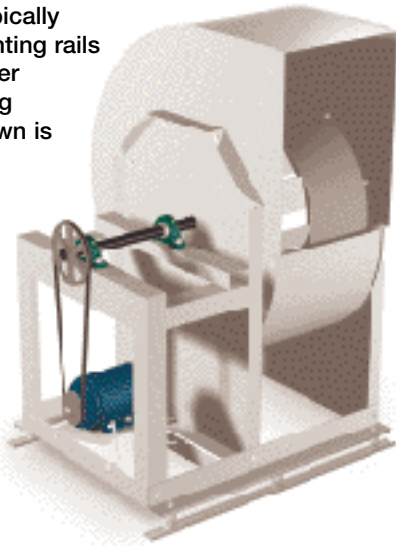

Smaller centrifugal fans can be directly mounted on isolators. (Fan shown is a Model 18-BISW Arr. 10)

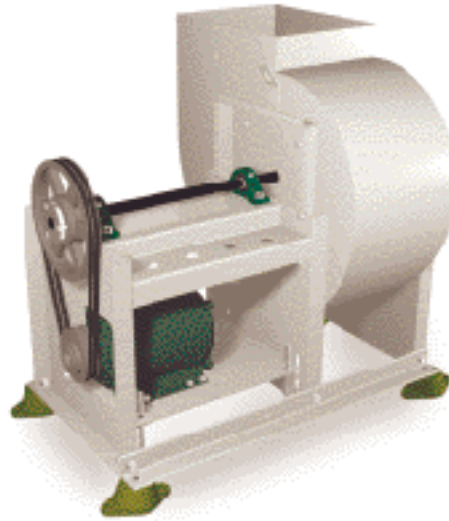

Belt drive plenum fans are typically mounted on structural bases and shipped as a packaged unit including motor and drives. (Fan shown is Model 36-PLN Arr.3)

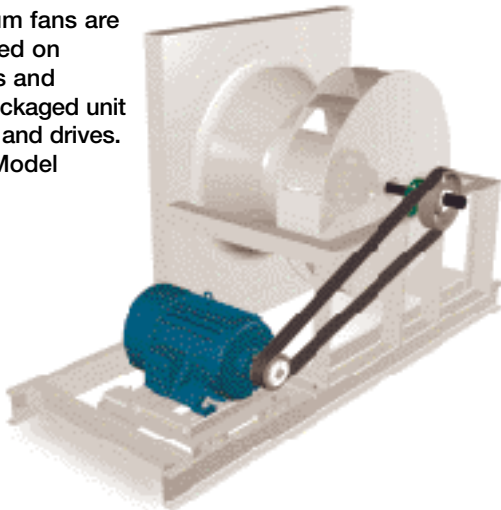

Larger centrifugal fans and all sizes of Arr. 1 or 3 fans are typically mounted on structural bases. The fan shown in this photo is mounted on a structural base with height saving brackets and free standing springs. (Fan shown is Model 30 AFDW, Arr. 3)

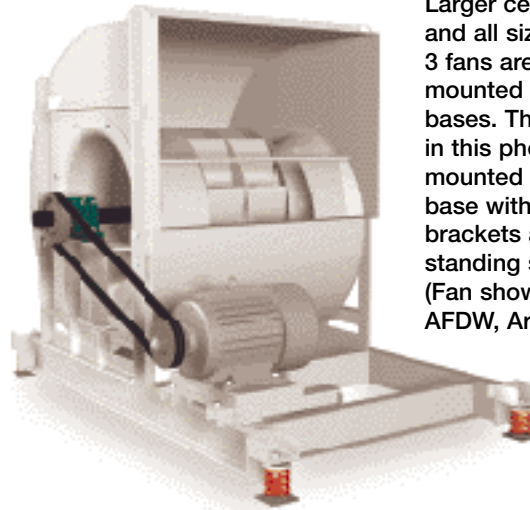

BENEFITS OF GREENHECK SUPPLIED BASES

Availability of detailed and accurate mounting dimensions is extremely important. Greenheck will furnish, upon request, submittal drawings for all bases specified.

In addition, to complete dimensional information the submittal includes isolator location and identification (see letters A, B, C D).

The isolators will be packaged and color coded for identification. The isolator package ships loose (not mounted).

An example of a base request form is shown on [page 8](#). This form guides you in furnishing all the information required to request your Greenheck base submittal drawing.

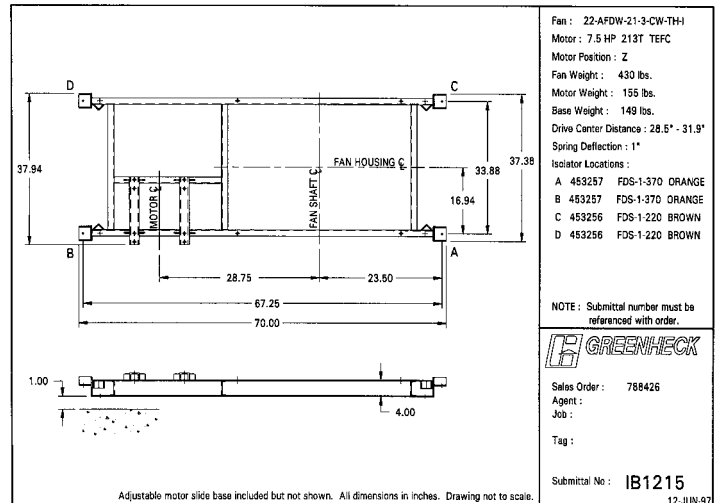

The example shown is for a 22" double width arrangement 3 fan with the motor in position Z. (This is the same unit as shown in the photo below).

MOST FANS WITH BASES CAN SHIP COMPLETELY ASSEMBLED AND TESTED

Most Greenheck fans that are ordered with motors, drives, guards and bases can be assembled, tested and shipped as a complete package.

For limitations on sizes that can be shipped assembled see information below.

Benefits:

- Installation time and costs are reduced.
 - Motors and drives are installed and aligned for smooth operation.
 - Guards and accessories are installed.
 - Vibration testing of the entire fan package (excluding utility fans) is performed.
- Belt drive fans are tested for maximum allowable vibration of 0.15 in /sec -peak (filter in). Vibration readings are taken at each bearing in the horizontal, vertical and axial direction. These vibration signatures become part of the fans permanent records and are available on request.

Mounting Limitations and Guidelines

- Fan and base must be ordered through GFC.
- Centrifugal fans up to size 33" and Industrial fans up to size 23" (40" wheel dia.) will be mounted to structural steel base as standard. (For fans to ship loose, factory must be notified)
- Consult factory for mounting larger sizes.
- Mounting larger sizes may require additional shipping costs.
- All inertia bases ship loose.
- Hardware and assembly instructions are included for bases shipped loose.

Typical Vibration Signature

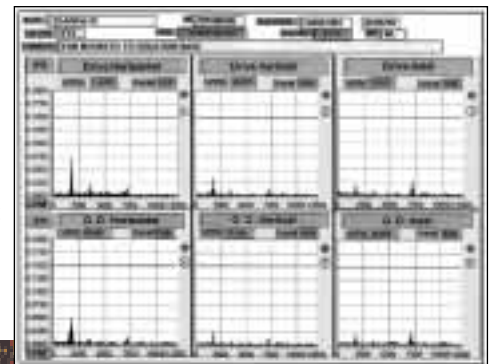

Copies of these signatures are kept on file and are available upon request



Assembled Fan Package on Vibration Test Stand

MOUNTING OPTIONS

The mounting options shown on this page (type A, B and C) relate to the Selection Guide For Vibration Isolation as published in the latest ASHRAE applications handbook, HVAC Applications-Sound and Vibration Control.

See page 6 for mounting selection based on fan arrangements and Greenheck fan types by model number.

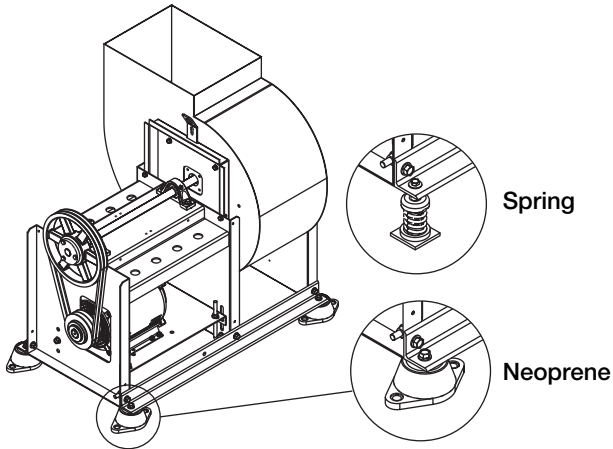

Direct Mount - Type A

No base required. Isolators are attached directly to equipment. Direct isolation can be used if equipment is unitary and rigid without the use of additional support. Direct isolation is not recommended for equipment having large overhung loads (e.g. motors on Arr. 9 fans). If there is any doubt that equipment can be supported directly on isolators, use rails, bases or consult the factory.

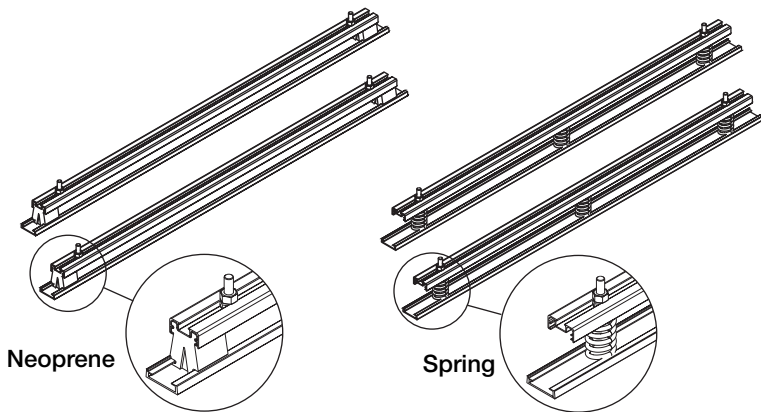

Mounting Rails - Type B1

Mounting rails consist of aluminum top and bottom rail construction with equipment mounting bolts which slide within slots for easier installation. Aluminum rails are available with 3 types of mounting: **1.** With neoprene mounting for up to 3/8" deflection **2.** With free-standing spring mounts for up to 1" static deflection. **3.** With zinc plated hardware and springs incorporating vertical limit stops providing up to 1" static deflection. This type is recommended for outdoor applications requiring rails with springs. (Rails are shipped loose not mounted)

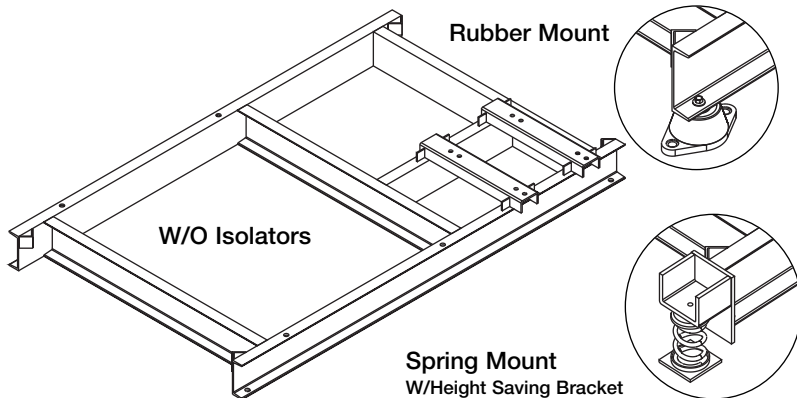

Structural Bases - Type B2

Structural steel bases consist of structural steel members welded into a rigid one piece base. Motor slide rails are included where applicable. Bases are required for all Arr. 1 and 3 fans with independently mounted motors. Structural steel bases are available without isolators, with rubber mounts or with spring mounts. All structural steel bases with spring mounts incorporate height saving brackets.

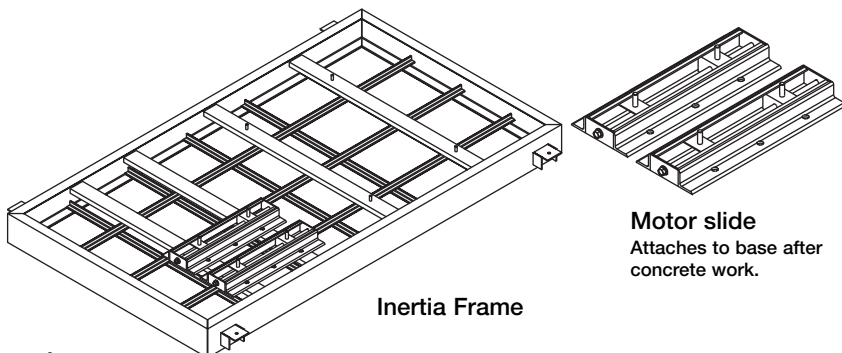

Inertia Bases - TYPE C

Inertia bases may be desirable where structural steel bases do not provide sufficient mass or where discharge velocities cause greater reaction forces. The additional weight of the concrete reduces the vibration amplitude and reduces reaction forces from fan thrust and start and stop motion. Concrete is by others. (Note: Motor slide rails are included on Arr. 1&3 fans)

ISOLATOR OPTIONS

Shown below are the various types of isolators available from Greenheck. The drawings below are representative of each type. The appearance will vary based on application and isolator manufacturer. See page 6 for isolator selection guidelines.

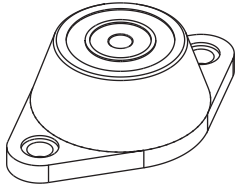

Rubber Mounts - Type 2

Neoprene mountings consist of a steel top plate and base plate completely embedded in colored (oil-resistant) neoprene for easy identification of capacity. Neoprene mountings are furnished with a tapped hole in the center. This enables the equipment to be bolted securely to the rubber mount.

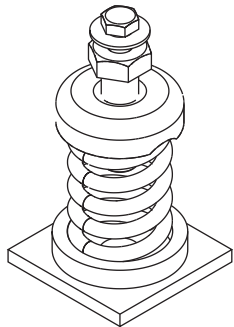

Free-Standing Open Spring Mounts - Type 3

Free-standing spring isolators are unboxed laterally stable steel springs. They provide a minimum horizontal stiffness of 0.8 times the rated vertical stiffness and provide an additional 50% overload capacity. These isolators are equipped with a top mounted adjusting bolt and an acoustical non-skid base. Springs are coded or identified to indicate load capacity.

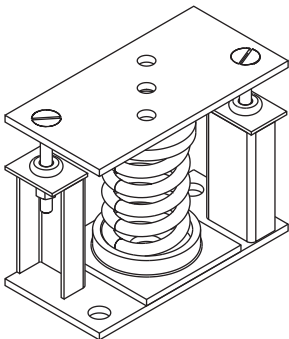

Restrained Spring Mounts - Type 4A

Restrained spring isolators consist of laterally stable, free-standing springs assembled into a steel housing. These assemblies are designed for vertical and horizontal motion restraint. Restrained spring isolators are provided with leveling bolts that can be used for blocking during equipment installation. Springs provide 50% overload capacity and are color coded or identified to indicate load capacity. Restrained spring mounts are recommended for equipment subject to wind loading or large torquing forces. They are also used for equipment subject to large weight changes such as swingout fans.

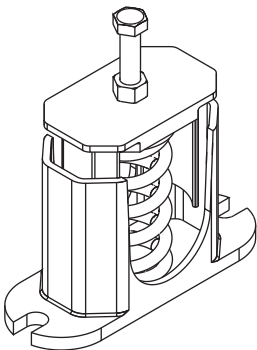

Housed Spring Mounts - Type 4B

Housed spring isolators consist of steel springs assembled into a telescoping housing with a top mounted adjusting bolt and an acoustical non-skid base. Housed spring isolators include resilient inserts to prevent metal-to-metal contact and provide snubbing for side loads. Springs provide an additional 50% overload capacity and are color coded or identified to indicate load capacity.

In addition to structural bases and isolators, your application may require thrust restraints and snubbers as shown below.

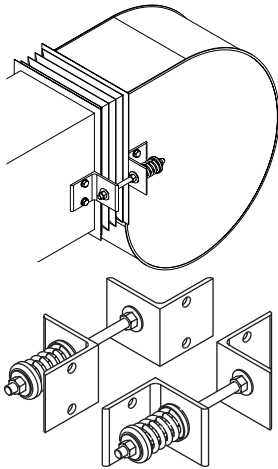

Thrust Restraints - Type 5

Thrust restraints, similar to spring mounts or hangers, are installed in pairs to resist reaction forces caused by air pressure. Thrust restraints are recommended where thrust exceeds approximately 10% of equipment weight. Thrust restraints should be selected with the same deflection requirements as spring isolators.

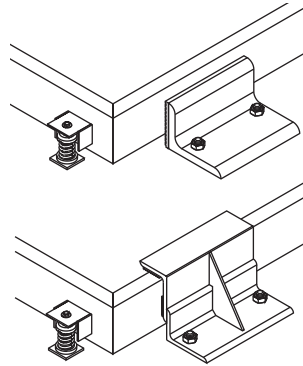

Snubbers

Snubbers are designed for use in locations where external forces could displace resiliently supported equipment. Snubbers anchored to the building limit equipment motion.

MOUNTING SELECTION GUIDE

The following shows the available mounting options for various fans. The size of motor, proximity to noise sensitive areas and building construction will affect the final selection. You must know the fan arrangement, the Greenheck model and fan size before making your selection. The first mounting selection stating “yes” will be the lowest cost. However, a second selection may be required depending on the application.

Arr.	Fan Type	Mounting Selection			
		Direct Mount	Mounting Rails ¹	Structural Base ²	Inertia Base ³
		Type A	Type B1	Type B2	Type C
1	AF/BISW IPA	NO	NO	YES	YES
3	AF/BISW AF/BIDW PLN	NO	NO	YES	YES
	PLN-HMOS/HMOT 12-36	CF	NO	YES	YES
	PLN-HMOS/HMOT 40-73	NO	NO	YES	YES
	PLN-VMOS 12-36	CF	NO	YES	NO
	PLN-VMOS 40-54	NO	NO	YES	NO
4	SFD	YES	YES	CF	CF
	PLN4	YES ⁴	NO	NO	YES ⁴
	IPA	CF	NO	YES	YES
8	IPA	CF	NO	YES	YES
9	AF/BISW 7-36 IPA 5-19	CF	NO	YES	YES
	AF/BISW 40-73 IPA 21-41	NO	NO	YES	YES
	SFB/SWB	YES	YES	CF	CF
10	AF/BISW 7-36	YES	NO	YES	YES
	AF/BISW 40-73	NO	NO	YES	YES
	IPA 5-19	YES ⁵	NO	YES	YES

Notes

1. Type B1 - Not available on DB, BAD or TAD discharges.
2. Type B2 - Consult factory on DB, BAD and TAD discharges
3. Type C - Not available on DB, BAD or TAD discharges.
4. Consult product literature for more mounting options
5. Type 'A' Direct Mount is not available if an inlet box is required

ISOLATOR SELECTION GUIDE

The most important part of selecting the proper isolator is determining the deflection required. The following examples will help guide you to selecting the proper isolator.

NOTE:

- Deflections of 1", 2", 3" and 4" will be assumed as nominal
- It is critical that deflections or efficiencies specified as minimum be stated as minimum on quotes and orders.
- When selecting an isolator, nominal deflection must be greater than minimum deflection.

Example 1:

If deflection is already specified, use that number for isolator selection process. Select isolator type based on required deflection and application as shown in Chart 1.

Deflection	Applications	Isolator Type
up to 1/4"	Indoor/Outdoor Where 0.3" or less deflection is required	Single Deflection Rubber Mount
up to 1/2"		Double Deflection Rubber Mount
1",2",3" or 4"	Indoor	Free Standing Spring Mounts
1",2",3" or 4"	Indoor/Outdoor Fans subject to wind loading or torquing forces	Restrained Spring Mounts
up to 1"*	Indoor Non-critical applications	Housed Spring Mounts

*consult factory above 1"

Chart 1

Example 2:

If isolator efficiency is specified, calculate the deflection required based on the fan RPM or motor RPM *whichever is lower*. The criteria shown in the sample below is illustrated in Chart 2 for approximate deflection. To calculate the deflection accurately use the following equation:

$$Deflection = \left[\frac{188 \sqrt{100/(100-E)+1}}{RPM} \right]^2$$

e.g. 95% Efficiency, 700 Fan RPM, 1800 motor RPM

$$\left[\frac{188 \sqrt{100/(100-95)+1}}{700} \right]^2 = 1.51"$$

In this example, select 2" deflection isolator

Note: These equations assume that the fan is installed on an extremely stiff foundation.

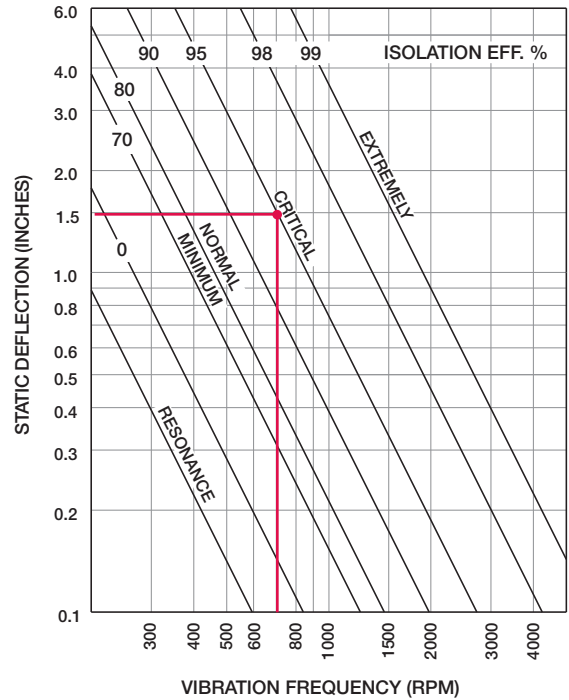

Chart 2

Example 3:

If no deflection or isolator efficiency is specified, then use the efficiencies shown in Chart 3 and calculate deflections as shown in Example 2.

**NOTE:* Assumes that the fan is installed on an extremely stiff foundation

Application	Efficiency*
Minimum	70-80%
Normal	80-90%
Critical	90-95%
Extremely Critical	95-99%

Chart 3

For further information on calculating deflection required, see ASHRAE Selection Guide for Vibration Isolation. This is especially important for critical and above grade applications.

SPECIFICATION CHECK LIST

To ensure proper isolation selection and application, the specifications must include the following information.

Fan Size _____

Model

- Utility : SFB SFD SWB
- Series 21: AFSW BISW
 AFDW BIDW
- Series 41: AFSW BISW
 AFDW BIDW
- Industrial: IPA IPO IPW
- Plenum: Horizontal: Standard
 Horizontal: Motor on Top
 Horizontal: Motor on Side
 Vertical (upblast)

Arrangement

- 1 3 4 8 9 10

Rotation

- CW CCW

Discharge

- TH BH UB TAU
- BAU DB TAD BAD

Class/Duty

- Series 21/41, plenum: I II III
- Industrial: Std. Hvy.

Motor Position

- Arrangement 9: Left Right
- Arrangements 1 & 3: W X Y Z

Fan RPM: _____

Motor

Horsepower: _____
RPM: _____
Frame Size: _____

Space Limits/Comments: _____

Mounting Rails

- Rails with Rubber Mounts
- Rails with Spring Mounts (Indoor)
- Rails with Spring Mounts (Outdoor)

Structural Steel Base

- Structural Base (no isolators)
- Structural Base with Rubber Mounts
Deflection: 1/4" 1/2"
- Structural Base with Spring Mounts
Deflection:
Nominal: 1" 2" 3" 4"
 Minimum: _____
- Isolator Type:
 Free Standing
 Housed
 Restrained

Concrete Inertia Base

- Inertia Base with Spring Mounts
Deflection:
Nominal: 1" 2" 3" 4"
 Minimum: _____
- Isolator Type:
 Free Standing
 Housed
 Restrained
- Base Thickness:
 Standard Depth
 Min. Depth _____
 6" 8" 10" 12"

Coating (on Base)

- Standard Coating
- Special Coating Required
- Specify Coating: _____

WARRANTY

Greenheck warrants this equipment to be free from defects in material and construction for a period of one year from the purchase date. Any units or parts which prove to be defective during the warranty period will be repaired at our option when returned to our factory, transportation prepaid. Greenheck will not be responsible for any installation or removal costs.

Due to continuing research and development Greenheck reserves the right to change specifications without notice.