

Medium Pressure Axial Fans

Model TBI-FS Levels 3, 4 & 5

with Fabricated Steel Propeller

Belt Drive – Inline or Roof Mounted Upblast

- Clean Air or Fume Exhaust
- High Temperature Process Exhaust
- Emergency Smoke



First Inline fan in the industry to be UL/cUL Listed "Power Ventilator for Smoke Control Systems"

 **GREENHECK**
The Solution Company.

February 2002

Axial Inline Fans

Model TBI-FS inline fans are the ideal choice for installations with straight-through airflow in ducted or unducted systems. These axial fans are designed for commercial and industrial applications where large air volumes are required at low to moderate pressures. TBI-FS models have continuously welded housing and are belt drive with motors and drives out of the airstream.

Typical applications include:

- General exhaust, supply or return air
- Industrial space and warehouse ventilation
- UL/cUL listed for emergency heat and smoke removal
- High temperature process ventilation

Industrial Duty Propellers

TBI-FS fabricated steel propellers are available in two levels of construction and include “Low and High” pressure blade pitch angles. Each angle is selected to optimize the fan’s efficiencies for a wide range of performances. All propellers are constructed with airfoil blades that are continuously welded to heavy duty hubs to ensure long life in the harshest commercial or industrial applications.

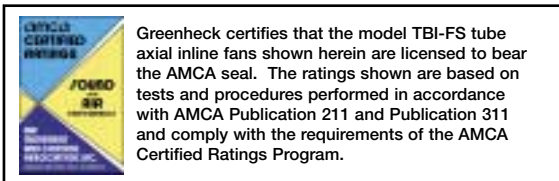
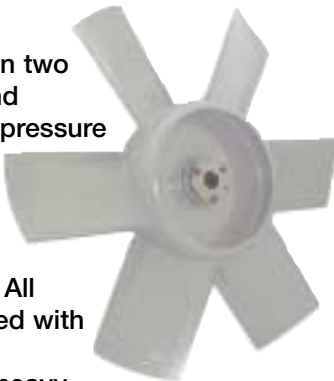

Level 3 - Tube Axial

- Maximum pressure capabilities of 2 inches wg (500 Pa)
- Volume 3,900 - 52,000 cfm (6,600 - 88,000 m³/hr)
- Highest efficiencies at static pressures below 1.5 inches wg (370 Pa)



Level 4 - Medium Pressure Axial

- Maximum pressure capabilities of 4 inches wg (1,000 Pa)
- Volume 3,300 - 77,000 cfm (5,600 - 130,000 m³/hr)
- Highest efficiencies at static pressures above 1.5 inches wg (370 Pa)



Level 5 - Vane Axial

- Maximum pressure capabilities of 4.5 inches wg (1,120 Pa)
- Volume 3,300 - 77,000 cfm (5,600 - 130,000 m³/hr)
- Highest efficiencies at static pressures above 1.5 inches wg (370 Pa)
- Designed to Level 4 construction specifications with added bolt-on vane section



Leading Edge Support

All Greenheck's products are supported by the industry's best product literature, electronic media, and Computer Aided Product Selection program (CAPS). You'll also find extensive product and Installation and Operation Manual (IOM) information on the Internet.

And, of course, you can always count on the personal service and expertise of our national and international representative organization. To locate your nearest Greenheck's representative call 715-359-6171 or visit our website at www.greenheck.com



Quick Delivery and Quick Build Programs

Greenheck's Quick Delivery (QD) and Quick Build (QB) Programs ensure rapid response time with your needs dictating manufacturing time. Use CAPS or visit www.greenheck.com/qd to determine what programs are available for these products.



Electrostatic Powder Paint

Powder coatings offer a uniform, durable and high quality finish. Powder coating is a one-coat process applied over a phosphatized surface that meets or exceeds the corrosion resistance of a comparable wet paint.

Greenheck offers a number of in-house coatings applied via “electrostatic powder.” The standard coating, Permator, is excellent for indoor or outdoor applications and also has resistance to many common chemicals. See Greenheck’s Product Application Guides for a complete list of available coatings and their chemical resistance. An updated list is available on-line at www.greenheck.com.

Maintenance / Serviceable Construction Advantages

The following value added features have been incorporated into the design to allow for quick and easy field service.

- Bearing lubrication is performed through extended grease fittings located on the outside of the fan housing.
- An adjustable motor base is provided for tightening the fan belts.
- Level 5’s bolt-on vane section can be removed to allow access to hub and blades.
- Propellers are easily removed with the use of taper lock bushings.

For additional access to the propeller and internal fan components for field service, see the “Easy Access Construction” option in the Accessories section.



Complete Assembly and Testing

The TBI-FS fan is completely assembled and tested before shipment. Our inspectors ensure that the fan is vibration free and that they are electrically safe for field operation.

Easy to Install and Operate

The compact design helps when fitting into tight spaces. In addition, integral connection punched flanges or optional Universal Mounting brackets accommodate motor position changes for last minute modifications or unexpected installation obstacles. Also available in roof upblast configuration (see pg. 5).

Reading the Cataloged Data

Model Number Code

The model number system is designed to completely identify the fan. A detailed explanation of the model number code for TBI-FS is shown.

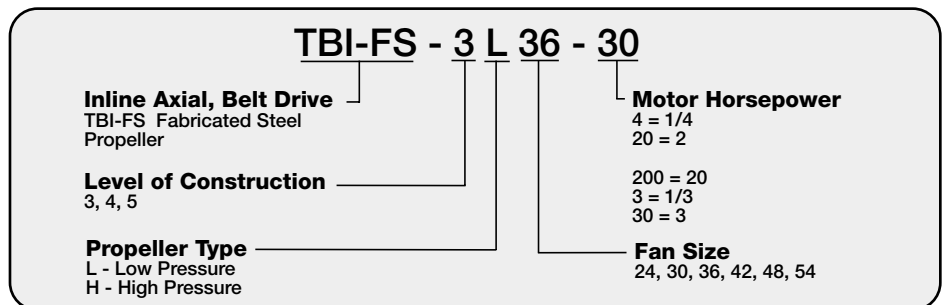

Sound Power vs. Sound Pressure

The sound values displayed on the following performance pages are in terms of inlet sound power (L_{wA}), or the acoustic power radiating from the inlet of the fan. Sound pressure, expressed as dBA, is the acoustic pressure at a point in space which can be measured with a microphone or can be heard. To convert sound power (L_{wA}) into sound pressure (dBA), the following corrections are typically applied.

Distance from fan	3ft (0.9m)	5ft (1.5m)	10ft (3.0m)
Correction	7	11.5	17.5

$$dBA = L_{wA} - \text{Correction}$$

Note: Refer to AMCA Publication 303, Application of Sound Power Level Ratings, for additional information on calculating typical sound pressure levels for fan installations.

STANDARD CONSTRUCTION FEATURES

Housing

Housings are continuously welded to assure no air leakage. Standard housing material is painted steel with Permator coating. Stainless steel construction available upon request.

Propellers - Airfoil

Propeller hubs and blades are sized to match performance requirements. Reinforced airfoil blades ensure efficient performance selections. Propellers are available in steel or stainless steel.

Inlet & Outlet Flanges

Integral inlet & outlet flanges with mounting holes are provided for airtight ductwork connections.

Bearings

Bearings are air handling quality, grease lubricated, pillow block type. Bearings are selected with a basic rating fatigue life (L10) in excess of 80,000 hours at each fan's maximum operating speed when mounted in a horizontal configuration.

Belt & Bearing Tube

Belts, bearings, and drives are protected from the airstream by heavy gauge steel belt tubes and bearing covers.

Adjustable Motor Bases

Rigid structural steel motor bases are welded to the fan housing and include heavy duty adjustment screws for belt tensioning.

Extended Lube Lines

Lubrication lines with grease fittings allow bearing lubrication without disassembling the fan.

Vane Section (Level 5)

Straightening vanes improve efficiencies 20% by making the air flow more uniform and less turbulent. Additionally this section can be removed to allow access to the fan propeller.



UNIVERSAL MOUNTING ACCESSORY

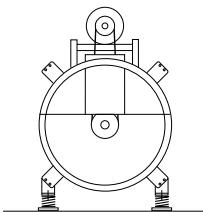

Horizontal Base Mount
Fig. 1

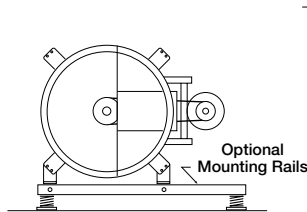

Horizontal Base Mount
Motor at 3 or 9 O'clock Position
Fig. 2

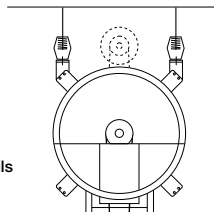

Horizontal Ceiling Hung
Fig. 3

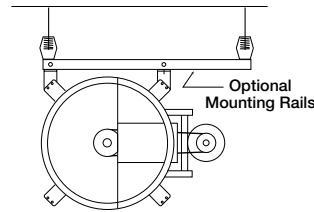

Horizontal Ceiling Hung
Motor at 3 or 9 O'clock Position
Fig. 4

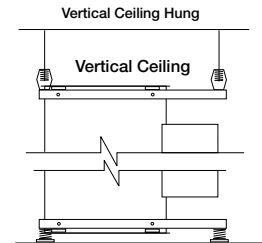

Vertical Ceiling Hung
Fig. 5

Horizontal and Vertical Mounting Configurations (Brackets Optional)

All fans can be mounted horizontally or vertically. For ease of installation, eight optional mounting brackets are welded on each fan. These eight brackets along with mounting supports provide for Greenheck's universal mounting system.

Fig. 1 Horizontal Base Mount

Each fan is shipped as standard in this arrangement. Motor at 12 o'clock is standard.

Fig. 2 Horizontal Base Mount with motor at 3 or 9 o'clock

A set of optional mounting rails are required for this installation. This is the base mounting position required with the easy access option.

Fig. 3 Horizontal Ceiling Hung

In this installation the supports can be positioned for mounting the motor at either 6 or 12 o'clock.

Fig. 4 Horizontal Ceiling Hung with motor at 3 or 9 o'clock A set of optional mounting rails are required for this installation.

Fig. 5 Vertical Mount

All TBI-FS fans can be mounted vertically (ceiling hung or base mount) for either upward or downward airflow. Optional mounting rails are recommended for belt driven fans.

NOTE:

All fans are shown with optional mounting brackets and vibration isolators. See the appropriate submittal drawings or installation manual for complete dimensional data.

High Temperature - Emergency Smoke Options - UL/cUL Listed

Model TBI-FS axial fans can withstand high temperature process exhaust or emergency smoke and heat relief. The table to the right lists temperature operation ranges and durations for each high temperature option.

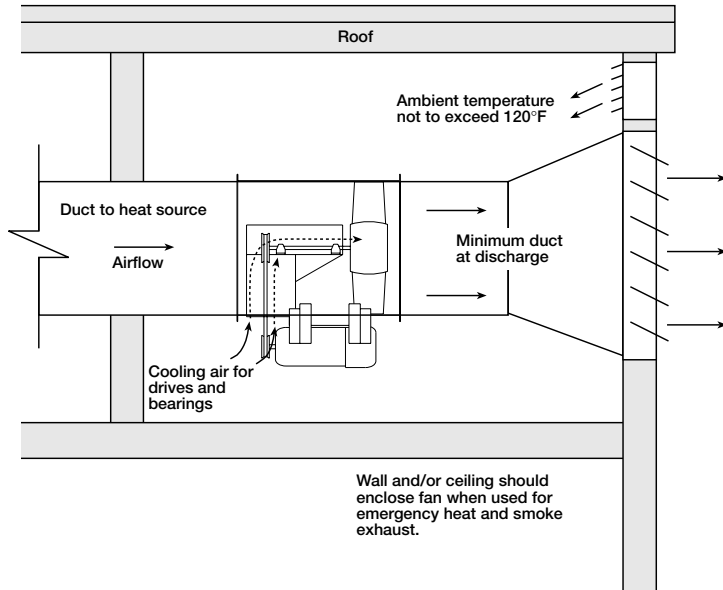

For the greatest amount of internal cooling discharge static pressure should be kept to a minimum while keeping most of the pressure on the inlet side. Locate the fan at ends of the duct runs and near the discharge point in the system. This set-up will promote the ambient air cooling effect.

High Temp Option	Operating Temperature		Time Duration
	F°	C°	Hours
Std. Construction	180	82	Continuous
HT-I	400	260	Continuous
HT-II	500	260	4
	572	300	1
HT-III	752	400	2
	1000	538	1
HT-UL/cUL	300	149	5
	750	399	4
	1000	538	0.25

- **HT-I Designed for Continuous Duty** industrial applications. Includes high temperature paint and copper extended lubrication lines.
- **HT-II Emergency Smoke Construction** that meets Industrial Risk Insurers (IRI) requirements of 500° F operation for a minimum of 4 hours.
- **HT-III Emergency Smoke Construction** that meets Southern Building Code Congress International (SBCCI) requirements of 1000° F for a 15 minutes. HT-III also exceeds IRI requirements listed in HT-II option.
- **HT-IV UL/cUL Listed** for “Power Ventilators for Smoke Control”. This construction option meets or exceeds IRI and SBCCI and includes a UL/cUL Power Ventilators for Smoke Control label adhered to the product.

All high temperature options include a minimum of dual groove drives.



Roof Upblast Construction

The upblast configuration is ideal for exhausting contaminants, smoke or high temperature air away from the building to prevent roof damage and intake air contamination. Additional features include: windband, butterfly dampers, curb cap and motor cover. Consult the Greenheck Computer Aided Product Selection (CAPS) program or a Greenheck representative for performance information.



Easy Access Construction

The Easy Access option is highly recommended to provide inspection, cleaning, and service of internal fan components. This option allows for the removal of the fan shaft and bearings through the housing without removing the fan from the duct. For service or removal of the propeller, the inspection section with removable access panel is recommended.

Universal Mounting Brackets

Universal Mounting brackets include all hardware necessary to position the fan horizontally or vertically in either base mount or ceiling hung applications.

Mounting Rails

Mounting rails are recommended for horizontal mounting of TBI-FS fans when the motor is to be located in the 3 or 9 o'clock position or for any vertically mounted applications. *Universal mounting brackets are required.*



Companion Flanges

Companion inlet flanges and outlet flanges with prepunched holes are available for all fan sizes.

Belt Guard

Belt guards provide protection from rotating pulleys and belts. Belt guards meet OSHA standards.

Motor Cover

Weatherproof motor covers shields the motor and drive components from dust, dirt and from moisture for indoor/outdoor installations. Motor cover guards meet OSHA standards.

Inspection Section

Inspection sections are an easily removable length of duct and are recommended to improve serviceability. Inspection sections are provided with a full diameter removable access panel.

Inspection Door

Bolted or hinged, inspection doors provide access through the fan tube for inspection of the propeller, bearings and drives.

Inlet and Outlet Guards

Removable inlet and outlet guards provide protection for personnel and equipment in ducted or non-ducted installations. Guards meet OSHA standards.

Inlet Bell w/ Inlet Guard

Inlet bells minimize entry losses in non-ducted applications by providing more uniform airflow into the propeller blades. Inlet bells are furnished with inlet guards that meet OSHA standards.

Isolators

Both base mount or hanging isolators are available in either neoprene or spring mounts. The isolators are furnished in sets of four and are sized to match the weight of each fan.

Special Coatings

Special coatings are available for protective purposes. Coatings are applied before assembly so that each manufactured component is coated inside and out. Painting the exterior a specified color for appearance is also an option. Consult Greenheck's Special Coating Bulletin or consult your factory representative for details.

UL/cUL 705

UL/cUL 705 electrical listing on 50 or 60 hz motors. Motors are supplied by Greenheck.



Disconnect Switches

Toggle type and heavy duty disconnect switches are available for positive electrical shut-off and safety in servicing fans. Switches can be factory mounted or shipped loose for field mounting.



- NEMA-1 – General purpose
- NEMA-3R – Rainproof
- NEMA-4 – Watertight
- NEMA-7 & 9 – Class 1 and Class 2 hazardous locations.

Greenheck will not factory mount NEMA-7 & 9 disconnect switches.

Windband w/ Butterfly Dampers

Bolt on section that eliminates rain penetration from upblast, roof mounted units. Gasket over raw edge reduces damper noise when closing.

Curb Cap

Provides transition from square roof curb to tubular fan housing. Welded to fan inlet and includes reinforcing gussets for extra strength.

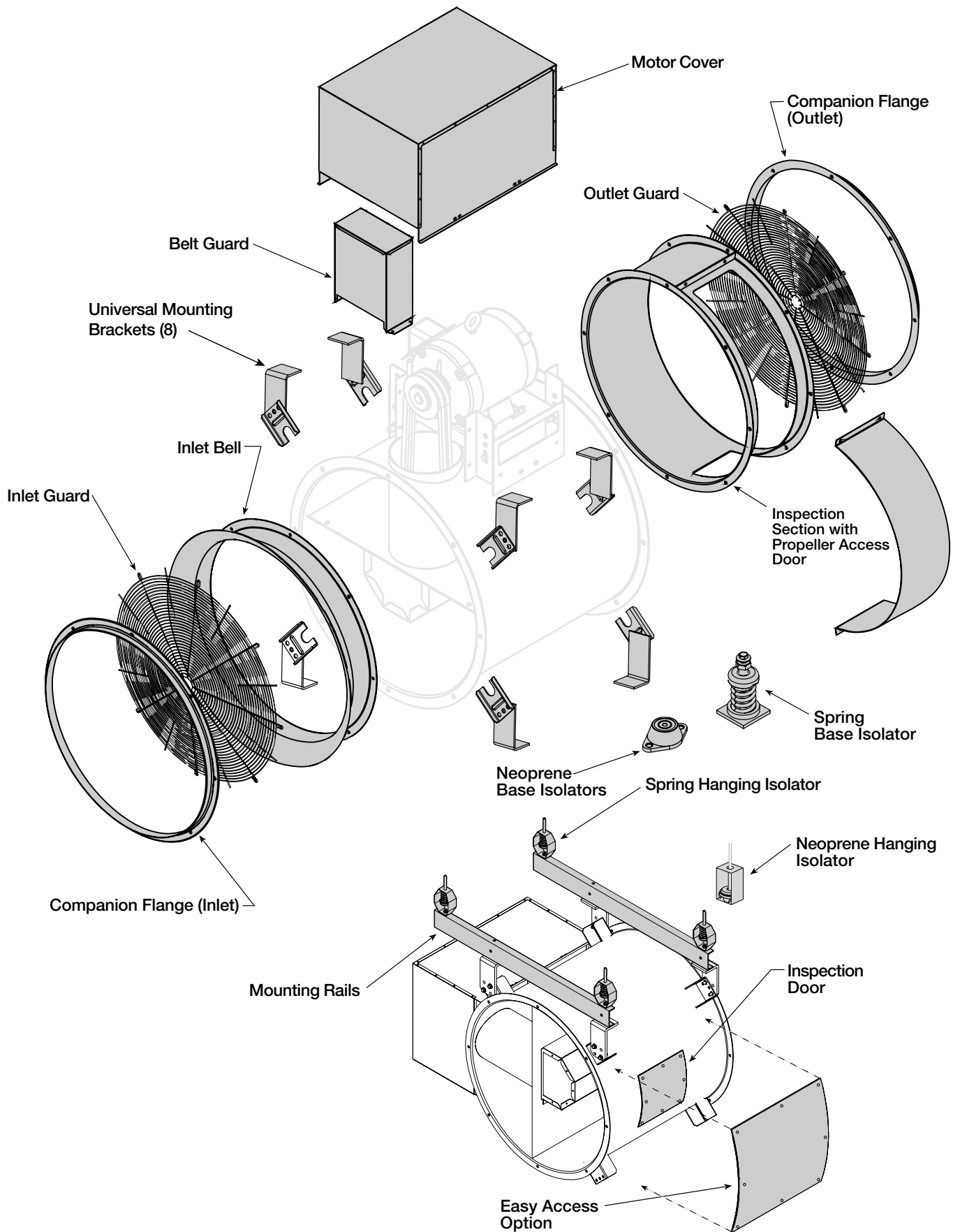

TBI-FS 24 Level 3 Belt Drive



Shown with Optional Brackets

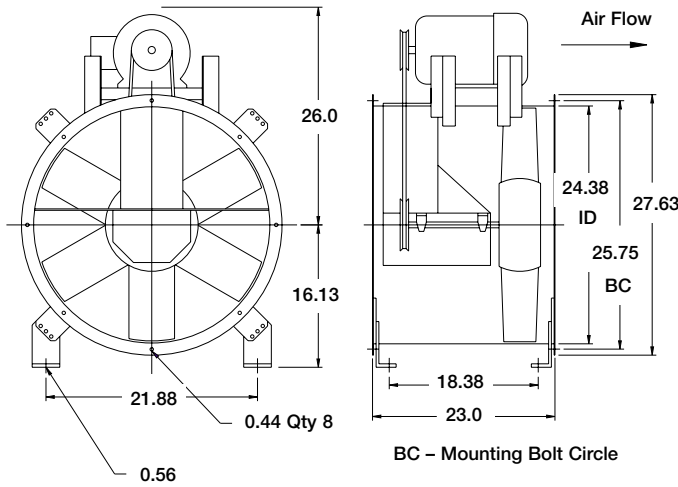

Specifications

- Max FRPM - L = 1798
- Max FRPM - H = 1988
- Max Motor Frame size = 184T
- Shaft Diameter = 1 in.
- Fan Tube Gauge = 12 ga.
- Approx. Weight (Steel) = 150 lbs.

Outlet Velocity (FPM) = CFM / 3.24 ft²
Tip Speed = FRPM x 6.28

Performance Data - Level 3

Optimum selection for propeller type shown in bold. Refer to page 3 for sound pressure corrections.

Model Number	Motor HP	Fan RPM	Max BHP	* L _{wi} A	CFM / Static Pressure in Inches WG												
					0.125	0.250	0.375	0.500	0.625	0.750	0.875	1.000	1.125	1.250	1.375	1.500	
					CFM	CFM	CFM	CFM	CFM	CFM	CFM	CFM	CFM	CFM	CFM	CFM	CFM
3L24-5	1/2	971	0.50	80	5425	4863											
3L24-5	1/2	989	0.55	81	5543	5010	3978										
3H24-5	1/2	1075	0.50	82	5158	4737	4139										
3H24-5	1/2	1107	0.57	82	5334	4936	4387	3314									
3L24-7	3/4	1105	0.75	84	6295	5882	5240										
3L24-7	3/4	1135	0.83	85	6487	6087	5509	4394									
3H24-7	3/4	1227	0.75	85	5985	5648	5236	4658									
3H24-7	3/4	1252	0.83	87	6119	5791	5396	4863	3930								
3L24-10	1	1213	1.00	87	6980	6611	6149	5475									
3L24-10	1	1254	1.10	87	7238	6885	6480	5852									
3H24-10	1	1345	0.95	88	6614	6317	5978	5573	4968								
3H24-10	1	1378	1.10	89	6789	6503	6183	5798	5263	4406							
3L24-15	1 1/2	1387	1.50	90	8071	7762	7433	6989	6406	5251							
3L24-15	1 1/2	1428	1.65	91	8327	8030	7711	7322	6779	6006							
3H24-15	1 1/2	1553	1.50	93	7714	7474	7204	6903	6562	6107	5531						
3H24-15	1 1/2	1578	1.65	94	7846	7612	7346	7058	6722	6300	5758	4883					
3L24-20	2	1531	2.00	91	8967	8697	8400	8102	7654	7123	6339						
3L24-20	2	1575	2.20	92	9240	8982	8692	8403	8012	7522	6902						
3H24-20	2	1694	2.00	95	8455	8242	7999	7751	7454	7141	6724	6219	5493				
3H24-20	2	1740	2.20	95	8696	8489	8256	8015	7741	7436	7076	6631	6081				
3L24-30	3	1751	3.00	95	10327	10095	9847	9587	9327	8983	8558	8071	7381				
3L24-30	3	1798	3.30	95	10616	10391	10154	9900	9647	9360	8946	8499	7979	7090			
3H24-30	3	1926	3.00	97	9667	9480	9286	9068	8850	8603	8328	8052	7665	7240	6744	5876	
3H24-30	3	1988	3.30	99	9990	9810	9627	9416	9204	8985	8718	8452	8138	7754	7308	6827	

Performance shown is for installation type B: free inlet, ducted outlet. Power rating (BHP) does not include drive losses. Performance ratings do not include the effects of appurtenances in the airstream.

The sound power level ratings shown are in decibels, referred to 10⁻¹² watts calculated per AMCA Standard 301. Values shown are for inlet L_{wi}A sound power levels for installation type B: free inlet, ducted outlet. Ratings do not include the effects of end correction.

* Sound power values shown are at the peak cataloged pressure for each RPM.

Shown with Optional Brackets

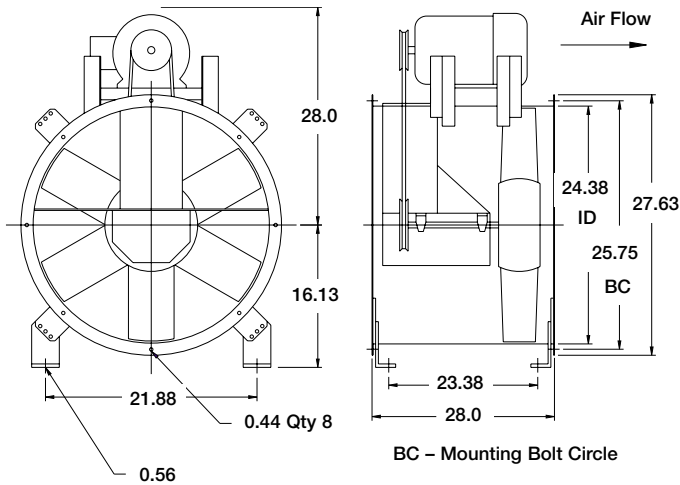

Specifications

- Max FRPM - L = 2494
- Max FRPM - H = 2707
- Max Motor Frame size = 215T
- Shaft Diameter = 1 3/16 in.
- Fan Tube Gauge = 10 ga.
- Approx. Weight (Steel) = 225 lbs.

Outlet Velocity (FPM) = CFM / 3.24 ft²
Tip Speed = FRPM x 6.28

Performance Data - Level 4

Optimum selection for propeller type shown in bold. Refer to page 3 for sound pressure corrections.

Model Number	Motor HP	Fan RPM	Max BHP	* L _{wi} A	CFM / Static Pressure in Inches WG											
					0.500	0.750	1.000	1.250	1.500	1.750	2.000	2.250	2.500	3.000	3.500	4.000
					CFM	CFM	CFM	CFM	CFM	CFM	CFM	CFM	CFM	CFM	CFM	CFM
4L24-10	1	1122	1.00	85	5439											
4L24-10	1	1162	1.10	86	5830											
4H24-10	1	1218	1.00	87	4750	2963										
4H24-10	1	1258	1.10	87	5041	3429	2279									
4L24-15	1½	1283	1.50	89	6900	5461										
4L24-15	1½	1324	1.65	90	7234	6050										
4H24-15	1½	1394	1.50	89	5852	5027	3274	2457								
4H24-15	1½	1439	1.65	90	6116	5399	3802	2782								
4L24-20	2	1418	2.00	92	7966	7089										
4L24-20	2	1468	2.25	93	8339	7570	6110									
4H24-20	2	1535	2.00	92	6669	6139	4971	3450	2749							
4H24-20	2	1588	2.20	92	6969	6459	5568	4008	3130							
4L24-30	3	1622	3.00	94	9469	8862	8037									
4L24-30	3	1668	3.30	95	9802	9233	8482	7219								
4H24-30	3	1756	3.00	95	7904	7453	6979	6009	4582	3667						
4H24-30	3	1812	3.30	95	8213	7779	7328	6601	5237	4054	3460					
4L24-50	5	1917	5.01	99	11550	11090	10589	9979	9162							
4L24-50	5	1978	5.50	99	11961	11535	11062	10494	9761	8605						
4H24-50	5	2082	5.01	99	9647	9601	8922	8530	8009	7158	5916	4805	4266			
4H24-50	5	2149	5.51	100	9992	9672	9308	8929	8535	7851	6760	5593	4731			
4L24-75	7½	2193	7.50	103	13397	13082	12655	12228	11711	11090	10316					
4L24-75	7½	2270	8.26	104	13909	13622	13218	12805	12341	11825	11134	10148				
4H24-75	7½	2383	7.51	103	11187	10951	10623	10294	9952	9609	9080	8362	7312	5380	4476	
4H24-75	7½	2460	8.26	103	11579	11352	11050	10732	10405	10073	9688	9090	8238	6208	5024	
4L24-100	10	2414	10.01	106	14861	14591	14259	13871	13483	13020	12520	11871	10998			
4L24-100	10	2494	11.00	108	15389	15128	14833	14458	14082	13670	13208	12646	12018			
4H24-100	10	2622	10.00	105	12399	12186	11940	11641	11343	11032	10721	10376	9814	8154	6292	5315
4H24-100	10	2707	11.00	106	12829	12622	12403	12114	11825	11529	11228	10926	10491	9161	7285	5907

Performance shown is for installation type B: free inlet, ducted outlet. Power rating (BHP) does not include drive losses. Performance ratings do not include the effects of appurtenances in the airstream.

The sound power level ratings shown are in decibels, referred to 10⁻¹² watts calculated per AMCA Standard 301. Values shown are for inlet L_{wi}A sound power levels for installation type B: free inlet, ducted outlet. Ratings do not include the effects of end correction.

* Sound power values shown are at the peak cataloged pressure for each RPM.

TBI-FS 30

Level 3 Belt Drive



Shown with Optional Brackets

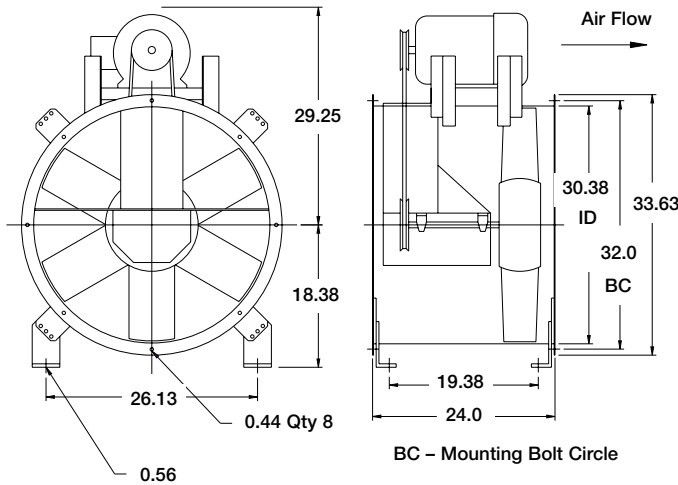

Specifications

- Max FRPM - L = 1534
- Max FRPM - H = 1834
- Max Motor Frame size = 184T
- Shaft Diameter = 1 1/4 in.
- Fan Tube Gauge = 12 ga.
- Approx. Weight (Steel) = 190 lbs.

Outlet Velocity (FPM) = CFM/5.03 ft²
 Tip Speed = FRPM x 7.85

Performance Data - Level 3

Optimum selection for propeller type shown in bold. Refer to page 3 for sound pressure corrections.

Model Number	Motor HP	Fan RPM	Max BHP	* L _{wi} A	CFM / Static Pressure in Inches WG												
					0.125	0.250	0.375	0.500	0.625	0.750	0.875	1.000	1.125	1.250	1.375	1.500	
					CFM	CFM	CFM	CFM	CFM	CFM	CFM	CFM	CFM	CFM	CFM	CFM	CFM
3L30-7	3/4	794	0.75	82	8256	7326											
3L30-7	3/4	822	0.83	82	8603	7732											
3H30-7	3/4	945	0.75	86	7162	6638	5833	4467									
3H30-7	3/4	976	0.83	87	7430	6931	6193	5079									
3L30-10	1	870	1.00	84	9192	8418	7192										
3L30-10	1	898	1.10	85	9534	8812	7724										
3H30-10	1	1039	1.00	89	7968	7504	6899	6059									
3H30-10	1	1073	1.10	90	8254	7810	7257	6522	5321								
3L30-15	1 1/2	996	1.50	88	10684	10085	9315	8101									
3L30-15	1 1/2	1028	1.65	89	11057	10490	9775	8762									
3H30-15	1 1/2	1189	1.50	93	9226	8841	8431	7852	7166	6096							
3H30-15	1 1/2	1228	1.65	94	9552	9184	8787	8265	7624	6749							
3L30-20	2	1098	2.01	91	11869	11367	10767	9975	8684								
3L30-20	2	1130	2.20	92	12239	11764	11204	10464	9447								
3H30-20	2	1309	2.00	96	10225	9891	9519	9106	8555	7927	7024						
3H30-20	2	1351	2.20	97	10573	10255	9895	9534	9009	8419	7664	6607					
3L30-30	3	1254	3.00	95	13667	13289	12784	12238	11562	10643							
3L30-30	3	1297	3.30	95	14160	13805	13324	12836	12187	11395	10223						
3H30-30	3	1498	3.00	100	11788	11509	11195	10870	10534	10059	9542	8993	8175	7140			
3H30-30	3	1547	3.31	101	12191	11922	11624	11309	10994	10572	10101	9570	8917	8104			
3L30-50	5	1488	5.00	98	16344	16034	15690	15265	14839	14312	13743	12990	12008				
3L30-50	5	1534	5.50	99	16868	16567	16253	15840	15428	14963	14410	13785	13002	11827			
3H30-50	5	1776	5.00	104	14070	13836	13601	13332	13058	12784	12500	12099	11699	11238	10776	10141	
3H30-50	5	1834	5.51	104	14545	14318	14090	13838	13572	13307	13041	12701	12313	11903	11455	11006	

Performance shown is for installation type B: free inlet, ducted outlet. Power rating (BHP) does not include drive losses. Performance ratings do not include the effects of appurtenances in the airstream.

The sound power level ratings shown are in decibels, referred to 10⁻¹² watts calculated per AMCA Standard 301. Values shown are for inlet L_{wi}A sound power levels for installation type B: free inlet, ducted outlet. Ratings do not include the effects of end correction.

* Sound power values shown are at the peak cataloged pressure for each RPM.

Shown with Optional Brackets

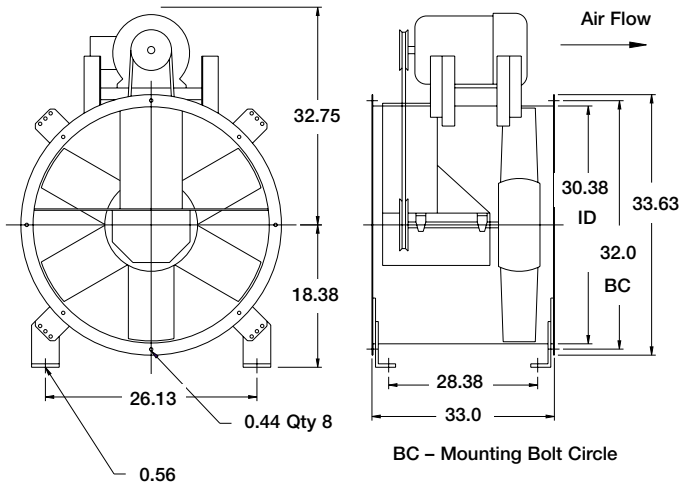

Specifications

- Max FRPM - L = 1923
- Max FRPM - H = 2306
- Max Motor Frame size = 254T
- Shaft Diameter = 1 7/16 in.
- Fan Tube Gauge = 10 ga.
- Approx. Weight (Steel) = 320 lbs.

Outlet Velocity (FPM) = CFM / 5.03 ft²
Tip Speed = FRPM x 7.85

Performance Data - Level 4

Optimum selection for propeller type shown in bold. Refer to page 3 for sound pressure corrections.

Model Number	Motor HP	Fan RPM	Max BHP	* L _{wi} A	CFM / Static Pressure in Inches WG												
					0.500	0.750	1.000	1.250	1.500	1.750	2.000	2.250	2.500	3.000	3.500	4.000	
					CFM	CFM	CFM	CFM	CFM	CFM	CFM	CFM	CFM	CFM	CFM	CFM	CFM
4L30-15	1 1/2	870	1.50	87	7653												
4L30-15	1 1/2	893	1.65	88	8355												
4H30-15	1 1/2	1037	1.50	90	7142	4771											
4H30-15	1 1/2	1072	1.65	91	7606	5373											
4L30-20	2	953	2.00	89	9474												
4L30-20	2	985	2.20	90	10420												
4H30-20	2	1145	2.00	91	8511	6666	4655										
4H30-20	2	1184	2.20	93	8945	7372	5274										
4L30-30	3	1091	3.01	92	11796	10151											
4L30-30	3	1125	3.30	94	12339	10843											
4H30-30	3	1308	3.01	95	10298	9251	7445	5619									
4H30-30	3	1351	3.30	95	10758	9814	8214	6371	4935								
4L30-50	5	1292	5.00	101	14793	13734	12392										
4L30-50	5	1335	5.50	101	15399	14428	13170										
4H30-50	5	1551	5.00	98	12831	12061	11215	9929	8198	6708	5562						
4H30-50	5	1598	5.51	99	13309	12569	11798	10732	9048	7529	6269						
4L30-75	7 1/2	1480	7.51	101	17421	16659	15666	14498	12422								
4L30-75	7 1/2	1529	8.25	101	18097	17359	16459	15375	13933								
4H30-75	7 1/2	1772	7.50	102	15062	14402	13721	13025	12047	10587	9136	7841	6791				
4H30-75	7 1/2	1831	8.25	103	15639	15011	14361	13687	12835	11672	10193	8866	7663				
4L30-100	10	1629	10.00	102	19460	18775	18052	17096	16021	14360							
4L30-100	10	1679	11.00	102	20128	19477	18805	17910	16914	15841							
4H30-100	10	1952	10.01	104	16777	16248	15649	15023	14391	13521	12379	10989	9721	7601			
4H30-100	10	2013	11.01	106	17348	16867	16286	15687	15074	14329	13463	12071	10779	8500			
4L30-150	15	1864	15.00	107	22584	22045	21440	20835	20019	19160	18193	16800					
4L30-150	15	1923	16.50	108	23362	22856	22270	21683	20966	20155	19251	18314	16420				
4H30-150	15	2234	15.00	108	19407	19074	18559	18035	17496	16944	16386	15606	14777	12330	10198	8478	
4H30-150	15	2306	16.50	109	20075	19752	19290	18783	18271	17736	17201	16555	15799	13614	11440	9546	

Performance shown is for installation type B: free inlet, ducted outlet. Power rating (BHP) does not include drive losses. Performance ratings do not include the effects of appurtenances in the airstream.

The sound power level ratings shown are in decibels, referred to 10⁻¹² watts calculated per AMCA Standard 301. Values shown are for inlet L_{wi}A sound power levels for installation type B: free inlet, ducted outlet. Ratings do not include the effects of end correction.

* Sound power values shown are at the peak cataloged pressure for each RPM.

TBI-FS 36

Level 3 Belt Drive



Shown with Optional Brackets

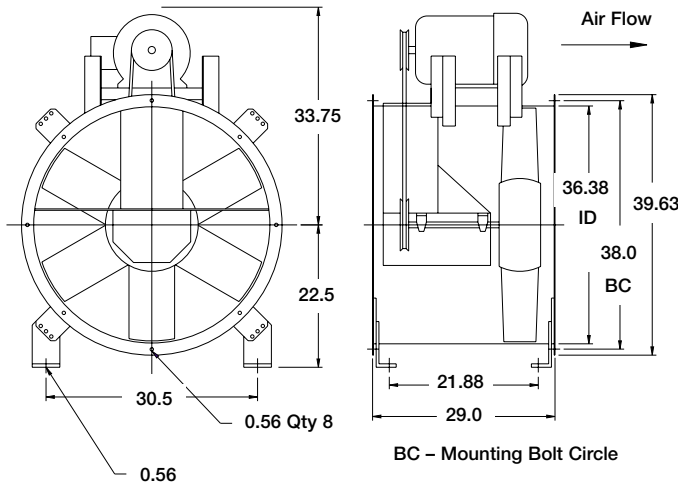

Specifications

- Max FRPM - L = 1325
- Max FRPM - H = 1476
- Max Motor Frame size = 215T
- Shaft Diameter = 1 1/2 in.
- Fan Tube Gauge = 12 ga.
- Approx. Weight (Steel) = 300 lbs.

Outlet Velocity (FPM) = CFM / 7.22 ft²
 Tip Speed = FRPM x 9.42

Performance Data - Level 3

Optimum selection for propeller type shown in bold. Refer to page 3 for sound pressure corrections.

Model Number	Motor HP	Fan RPM	Max BHP	* L _{wi} A	CFM / Static Pressure in Inches WG											
					0.125	0.250	0.375	0.500	0.625	0.750	0.875	1.000	1.125	1.250	1.375	1.500
					CFM	CFM	CFM	CFM	CFM	CFM	CFM	CFM	CFM	CFM	CFM	CFM
3L36-10	1	660	1.00	82	11834	10410										
3L36-10	1	683	1.10	83	12336	10993										
3H36-10	1	732	1.00	84	11123	10184	8027									
3H36-10	1	755	1.10	85	11531	10620	8962									
3L36-15	1 1/2	752	1.50	85	13802	12677	11258									
3L36-15	1 1/2	778	1.65	86	14345	13272	11955									
3H36-15	1 1/2	837	1.50	88	12976	12148	11258	8952								
3H36-15	1 1/2	865	1.65	89	13465	12662	11838	10021								
3L36-20	2	826	2.00	87	15342	14357	13199	11485								
3L36-20	2	854	2.21	88	15921	14983	13903	12523								
3H36-20	2	923	2.01	91	14474	13718	12975	11994	9542							
3H36-20	2	951	2.20	92	14959	14224	13502	12672	10593							
3L36-30	3	953	3.07	91	17953	17164	16258	15221	13935							
3L36-30	3	978	3.30	92	18463	17709	16826	15851	14728							
3H36-30	3	1055	3.00	96	16749	16082	15427	14779	13969	12106	10188					
3H36-30	3	1088	3.31	96	17306	16666	16030	15401	14689	13648	11170					
3L36-50	5	1127	5.07	95	21492	20843	20142	19376	18558	17615	16466					
3L36-50	5	1160	5.51	96	22159	21528	20865	20121	19373	18460	17502	14824				
3H36-50	5	1249	5.01	99	20011	19490	18930	18376	17828	17267	16545	15496	13177			
3H36-50	5	1291	5.50	101	20714	20221	19677	19141	18609	18080	17456	16614	14786	13073		
3L36-75	7 1/2	1289	7.58	100	24760	24186	23623	22987	22317	21647	20848	20014	19077	16065		
3L36-75	7 1/2	1325	8.25	100	25484	24924	24376	23777	23126	22473	21748	20949	20106	18868		
3H36-75	7 1/2	1432	7.52	103	23068	22656	22163	21676	21193	20714	20236	19730	19130	18295	16526	14845
3H36-75	7 1/2	1476	8.26	103	23800	23412	22934	22460	21991	21524	21061	20598	20045	19369	18550	16514

Performance shown is for installation type B: free inlet, ducted outlet. Power rating (BHP) does not include drive losses. Performance ratings do not include the effects of appurtenances in the airstream.

The sound power level ratings shown are in decibels, referred to 10⁻¹² watts calculated per AMCA Standard 301. Values shown are for inlet L_{wi}A sound power levels for installation type B: free inlet, ducted outlet. Ratings do not include the effects of end correction.

* Sound power values shown are at the peak cataloged pressure for each RPM.

Shown with Optional Brackets

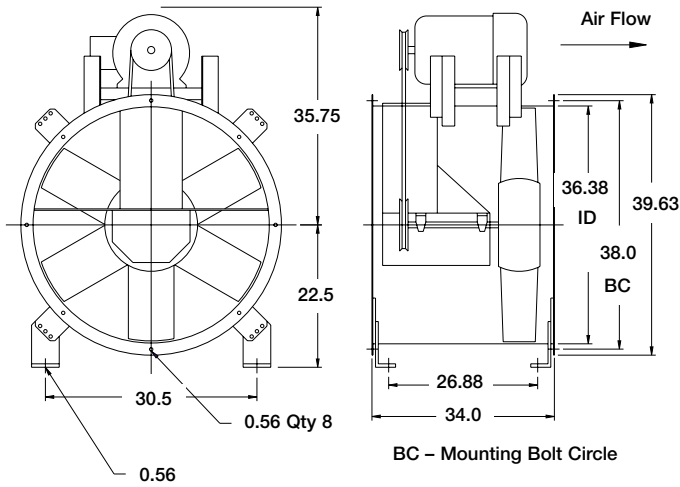

Specifications

- Max FRPM - L = 1748
- Max FRPM - H = 1824
- Max Motor Frame size = 256T
- Shaft Diameter = 1 11/16 in.
- Fan Tube Gauge = 10 ga.
- Approx. Weight (Steel) = 440 lbs.

Outlet Velocity (FPM) = CFM / 7.22 ft²
Tip Speed = FRPM x 9.42

Performance Data - Level 4

Optimum selection for propeller type shown in bold. Refer to page 3 for sound pressure corrections.

Model Number	Motor HP	Fan RPM	Max BHP	* L _{wi} A	CFM / Static Pressure in Inches WG											
					0.500	0.750	1.000	1.250	1.500	1.750	2.000	2.250	2.500	3.000	3.500	4.000
					CFM	CFM	CFM	CFM	CFM	CFM	CFM	CFM	CFM	CFM	CFM	CFM
4L36-20	2	782	2.01	88	11824											
4L36-20	2	809	2.20	89	12542											
4H36-20	2	828	2.01	88	10315	7589										
4H36-20	2	847	2.20	89	10747	8452										
4L36-30	3	907	3.01	91	14979											
4L36-30	3	939	3.30	92	15738											
4H36-30	3	940	3.00	92	12794	10824	7776									
4H36-30	3	972	3.31	93	13449	11522	9487									
4L36-50	5	1071	5.00	95	18886	17390										
4L36-50	5	1106	5.68	96	19708	18230	16724									
4H36-50	5	1116	5.05	96	16059	14906	13155	11628	8323							
4H36-50	5	1148	5.50	97	16607	15600	14023	12541	9350							
4L36-75	7 1/2	1225	7.50	99	22342	21067	19799									
4L36-75	7 1/2	1254	8.25	100	22975	21762	20498	19164								
4H36-75	7 1/2	1274	7.51	99	18735	17998	16892	15413	14101	12013	9133					
4H36-75	7 1/2	1315	8.26	100	19422	18740	17784	16443	14998	13589	10459					
4L36-100	10	1354	10.43	103	25138	24124	22868	21759	20467							
4L36-100	10	1381	11.00	103	25719	24740	23519	22412	21188							
4H36-100	10	1402	10.01	101	20870	20270	19522	18394	17063	15799	14409	11325	9474			
4H36-100	10	1446	11.01	102	21600	21018	20327	19358	18137	16753	15728	13686	10916			
4L36-150	15	1548	15.34	105	29205	28403	27494	26391	25396	24371						
4L36-150	15	1580	16.50	106	29867	29098	28242	27163	26160	25206	24076					
4H36-150	15	1604	15.02	106	24200	23677	23153	22494	21639	20542	19286	18226	17240	12600		
4H36-150	15	1657	16.50	107	25052	24562	24055	23458	22781	21724	20654	19370	18475	15224	11149	
4L36-200	20	1695	20.01	108	32235	31577	20779	29899	28892	27979	27092	26046				
4L36-200	20	1748	22.40	109	33323	32697	31938	31144	30168	29237	28377	27445	26423			
4H36-200	20	1765	20.02	107	29780	26355	25879	25401	24786	24074	23082	22077	20809	19128	14945	
4H36-200	20	1824	22.00	108	27723	27331	26870	26408	25857	25262	24376	23410	22419	20432	17999	13643

Performance shown is for installation type B: free inlet, ducted outlet. Power rating (BHP) does not include drive losses. Performance ratings do not include the effects of appurtenances in the airstream.

The sound power level ratings shown are in decibels, referred to 10⁻¹² watts calculated per AMCA Standard 301. Values shown are for inlet L_{wi}A sound power levels for installation type B: free inlet, ducted outlet. Ratings do not include the effects of end correction.

* Sound power values shown are at the peak cataloged pressure for each RPM.

TBI-FS 42 Level 3 Belt Drive



Shown with Optional Brackets

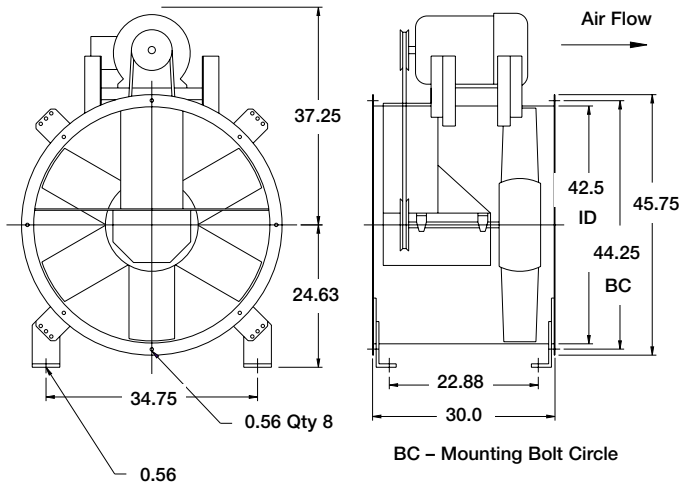

Specifications

- Max FRPM - L = 1154
- Max FRPM - H = 1271
- Max Motor Frame size = 215T
- Shaft Diameter = 1 1/2 in.
- Fan Tube Gauge = 10 ga.
- Approx. Weight (Steel) = 400 lbs.

Outlet Velocity (FPM) = CFM / 9.85 ft²
Tip Speed = FRPM x 11.0

Performance Data - Level 3

Optimum selection for propeller type shown in bold. Refer to page 3 for sound pressure corrections.

Model Number	Motor HP	Fan RPM	Max BHP	* L _{wi} A	CFM / Static Pressure in Inches WG												
					0.125	0.250	0.375	0.500	0.625	0.750	0.875	1.000	1.125	1.250	1.375	1.500	
					CFM	CFM	CFM	CFM	CFM	CFM	CFM	CFM	CFM	CFM	CFM	CFM	CFM
3L42-15	1 1/2	611	1.51	85	16553	15220											
3L42-15	1 1/2	617	1.69	85	16744	15417	11649										
3H42-15	1 1/2	719	1.50	89	14519	13582	12238	9417									
3H42-15	1 1/2	745	1.65	90	15117	14200	13015	10448									
3L42-20	2	666	2.00	87	18357	17008	15219										
3L42-20	2	690	2.21	88	18142	17779	16328										
3H42-20	2	791	2.00	90	16169	15284	14287	12655	9921								
3H42-20	2	817	2.20	91	16761	15892	15036	13638	11132								
3L42-30	3	762	3.01	91	21438	20129	19089	17243									
3L42-30	3	789	3.31	92	22260	21003	19968	18503									
3H42-30	3	909	3.01	93	18775	18029	17311	16371	15081	12678	9398						
3H42-30	3	935	3.31	94	19342	18637	17925	17121	16050	13564	11695						
3L42-50	5	887	5.01	94	25230	24151	23142	22274	20912	17405							
3L42-50	5	932	5.50	96	26587	25636	24612	23735	22747	21059							
3H42-50	5	1074	5.01	97	22360	21846	21164	20565	19961	18962	17786	15472	13914	10103			
3H42-50	5	1108	5.50	99	23096	22624	21957	21366	20785	19896	19054	17467	15346	13446			
3L42-75	7 1/2	1015	7.51	98	29080	28346	27289	26419	25662	24679	23137	19505					
3L42-75	7 1/2	1066	8.26	100	30608	29963	28916	28088	27310	26615	25431	23835					
3H42-75	7 1/2	1229	7.51	104	25709	25317	24770	24181	23658	23134	22422	21593	20588	18859	17105	15540	
3H42-75	7 1/2	1271	8.27	106	26614	26235	25738	25157	24642	24136	23624	22730	22012	20781	18537	17430	
3L42-100	10	1126	10.26	102	32401	31791	30889	30032	29247	28570	27842	26633	25060	21238			
3L42-100	10	1154	11.01	103	33237	32641	31809	30933	30167	29474	28832	27770	26381	23038			

Performance shown is for installation type B: free inlet, ducted outlet. Power rating (BHP) does not include drive losses. Performance ratings do not include the effects of appurtenances in the airstream.

The sound power level ratings shown are in decibels, referred to 10⁻¹² watts calculated per AMCA Standard 301. Values shown are for inlet L_{wi}A sound power levels for installation type B: free inlet, ducted outlet. Ratings do not include the effects of end correction.

* Sound power values shown are at the peak cataloged pressure for each RPM.

Shown with Optional Brackets

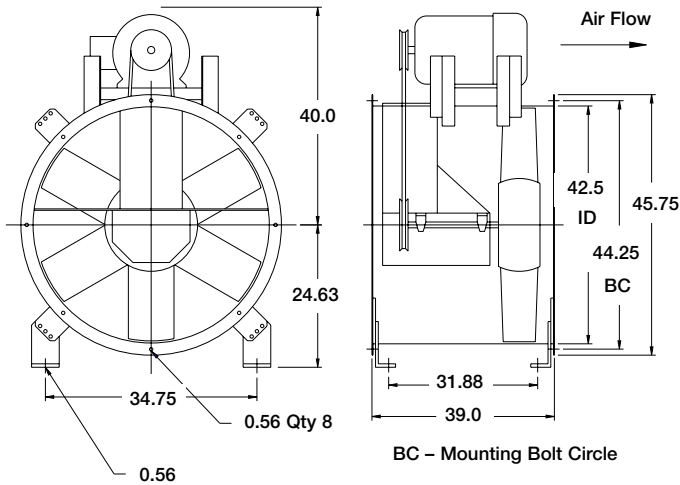

Specifications

- Max FRPM - L = 1436
- Max FRPM - H = 1607
- Max Motor Frame size = 284T
- Shaft Diameter = 1 11/16 in.
- Fan Tube Gauge = 3/16 in.
- Approx. Weight (Steel) = 640 lbs.

Outlet Velocity (FPM) = CFM / 9.85 ft²
Tip Speed = FRPM x 11.0

Performance Data - Level 4

Optimum selection for propeller type shown in bold. Refer to page 3 for sound pressure corrections.

Model Number	Motor HP	Fan RPM	Max BHP	* L _{wi} A	CFM / Static Pressure in Inches WG											
					0.500	0.750	1.000	1.250	1.500	1.750	2.000	2.250	2.500	3.000	3.500	4.000
					CFM	CFM	CFM	CFM	CFM	CFM	CFM	CFM	CFM	CFM	CFM	CFM
4L42-30	3	689	3.01	88	15343											
4L42-30	3	720	3.31	89	17293											
4H42-30	3	765	3.00	90	13747	10637	6722									
4H42-30	3	795	3.30	91	14552	11980	7549									
4L42-50	5	813	5.02	92	21799	16732										
4L42-50	5	843	5.51	93	22873	18738										
4H42-50	5	915	5.00	96	17430	16243	13701	9379								
4H42-50	5	936	5.50	96	17925	16812	14705	10443	8206							
4L42-75	7 1/2	930	7.52	96	25920	24169	18710									
4L42-75	7 1/2	962	8.26	97	27026	25407	20918									
4H42-75	7 1/2	1044	7.50	100	20458	19526	18414	16315	12938	9777						
4H42-75	7 1/2	1072	8.30	99	21111	20195	19175	17548	14582	10552	9229					
4L42-100	10	1040	10.52	99	29577	28280	25971	20934								
4L42-100	10	1057	11.01	100	30129	28880	27250	22114								
4H42-100	10	1142	10.02	101	22734	21851	21016	19896	17790	15004	11156	9928				
4H42-100	10	1187	11.01	102	23770	22906	22102	21126	19679	17081	13398	11174				
4L42-150	15	1174	15.00	103	33898	32955	31702	30018	25332							
4L42-150	15	1223	16.50	104	35464	34573	33435	32070	28427							
4H42-150	15	1312	15.20	104	26636	25834	25075	24348	23460	22320	20205	17816	14179	11277		
4H42-150	15	1356	16.50	106	27663	26857	26107	25404	24664	23672	22198	19818	17379	12501		
4L42-200	20	1298	20.00	105	37851	37012	36058	34926	33509	29267						
4L42-200	20	1332	22.00	106	38930	38112	37237	36133	34832	31405	27626					
4H42-200	20	1442	20.00	107	29659	28841	28125	27448	26787	26011	25097	23679	21453	15773	12876	
4H42-200	20	1492	22.00	108	30814	29988	29295	28625	27986	27347	26465	25462	23854	19492	14251	
4L42-250	25	1395	25.40	107	40922	40141	39360	38353	37255	35920	31748	28064				
4L42-250	25	1436	27.50	107	42216	41457	40698	39785	38761	37517	34334	30898				
4H42-250	25	1556	25.00	109	32285	31449	30785	30122	29509	28896	28194	28348	26247	22447	169960	14166
4H42-250	25	1607	27.50	110	33454	32626	31965	31322	30713	30120	29526	28736	27916	24753	20774	15561

Performance shown is for installation type B: free inlet, ducted outlet. Power rating (BHP) does not include drive losses. Performance ratings do not include the effects of appurtenances in the airstream.

The sound power level ratings shown are in decibels, referred to 10⁻¹² watts calculated per AMCA Standard 301. Values shown are for inlet L_{wi}A sound power levels for installation type B: free inlet, ducted outlet. Ratings do not include the effects of end correction.

* Sound power values shown are at the peak cataloged pressure for each RPM.

TBI-FS 48 Level 3 Belt Drive



Shown with Optional Brackets

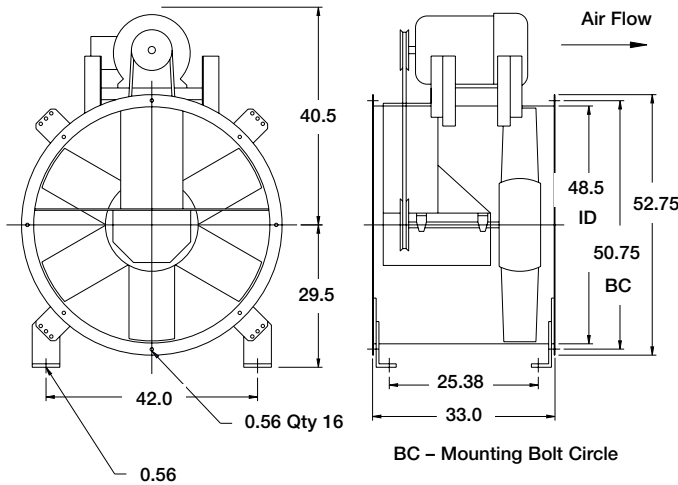

Specifications

- Max FRPM - L = 939
- Max FRPM - H = 1090
- Max Motor Frame size = 215T
- Shaft Diameter = 1 3/4 in.
- Fan Tube Gauge = 10 ga.
- Approx. Weight (Steel) = 525 lbs.

Outlet Velocity (FPM) = CFM / 12.83 ft²
 Tip Speed = FRPM x 12.6

Performance Data - Level 3

Optimum selection for propeller type shown in bold. Refer to page 3 for sound pressure corrections.

Model Number	Motor HP	Fan RPM	Max BHP	* L _{wi} A	CFM / Static Pressure in Inches WG											
					0.125	0.250	0.375	0.500	0.625	0.750	0.875	1.000	1.125	1.250	1.375	1.500
					CFM	CFM	CFM	CFM	CFM	CFM	CFM	CFM	CFM	CFM	CFM	CFM
3L48-15	1 1/2	479	1.50	82	18483	15544										
3L48-15	1 1/2	498	1.65	83	19378	16780										
3H48-15	1 1/2	598	1.50	86	16687	15189	12842									
3H48-15	1 1/2	625	1.66	87	17574	16128	14253									
3L48-20	2	537	2.01	85	21198	19012										
3L48-20	2	557	2.21	86	22091	20114										
3H48-20	2	647	2.01	89	18297	16892	15242	11596								
3H48-20	2	675	2.20	89	19232	17861	16444	13644								
3L48-30	3	608	3.01	89	24341	22764	20427									
3L48-30	3	631	3.31	90	25351	23930	21793									
3H48-30	3	745	3.00	92	21545	20246	19043	17510	14560							
3H48-30	3	773	3.41	94	22463	21186	20013	18714	16654	12515						
3L48-50	5	724	5.01	93	29403	28328	26822	24904								
3L48-50	5	744	5.84	94	30270	29261	27848	26028	22643							
3H48-50	5	885	5.01	96	26084	24889	23868	22847	21805	20209	17473					
3H48-50	5	906	5.51	98	26753	25576	24579	23576	22625	21165	19050	15622				
3L48-75	7 1/2	815	7.68	97	33336	32448	31319	29885	28156	24802						
3L48-75	7 1/2	849	8.25	98	24800	33947	32926	31639	30056	28186						
3H48-75	7 1/2	1005	7.50	101	29895	28869	27886	26986	26082	25228	24003	22540	19918	16776		
3H48-75	7 1/2	1039	8.25	101	30969	29990	29009	28139	27265	26421	25455	24127	22488	19565		
3L48-100	10	903	10.01	99	37200	36317	35455	34351	32987	31418	29530					
3L48-100	10	939	11.03	101	38799	37890	37119	36066	34849	33421	31864					

Performance shown is for installation type B: free inlet, ducted outlet. Power rating (BHP) does not include drive losses. Performance ratings do not include the effects of appurtenances in the airstream.

The sound power level ratings shown are in decibels, referred to 10⁻¹² watts calculated per AMCA Standard 301. Values shown are for inlet L_{wi}A sound power levels for installation type B: free inlet, ducted outlet. Ratings do not include the effects of end correction.

* Sound power values shown are at the peak cataloged pressure for each RPM.

Shown with Optional Brackets

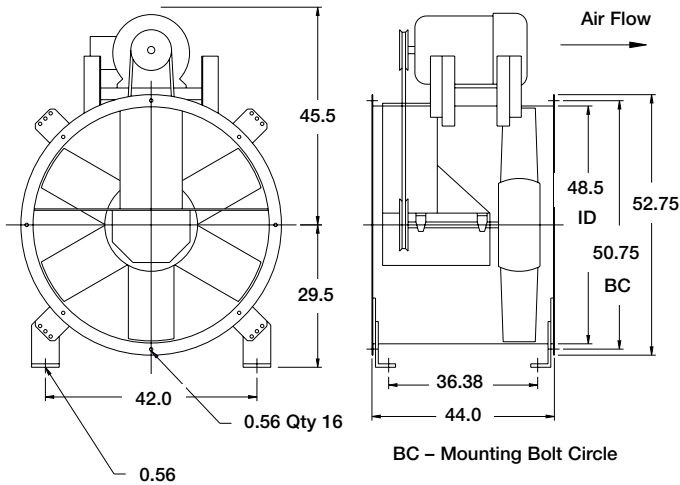

Specifications

- Max FRPM - L = 1430
- Max FRPM - H = 1509
- Max Motor Frame size = 324T
- Shaft Diameter = 1 15/16 in.
- Fan Tube Gauge = 3/16 in.
- Approx. Weight (Steel) = 895 lbs.

Outlet Velocity (FPM) = CFM / 12.83 ft²
Tip Speed = FRPM x 12.6

Performance Data - Level 4 Optimum selection for propeller type shown in bold. Refer to page 3 for sound pressure corrections.

Model Number	Motor HP	Fan RPM	Max BHP	* L _{wi} A	CFM / Static Pressure in Inches WG											
					0.500	0.750	1.000	1.250	1.500	1.750	2.000	2.250	2.500	3.000	3.500	4.000
					CFM	CFM	CFM	CFM	CFM	CFM	CFM	CFM	CFM	CFM	CFM	CFM
4L48-75	7 1/2	795	7.50	95	29849	26663										
4L48-75	7 1/2	827	8.26	96	31373	28743										
4H48-75	7 1/2	837	7.52	96	24496	22648	20527	15784								
4H48-75	7 1/2	864	8.26	97	25532	23725	21637	18313								
4L48-100	10	864	10.01	97	33121	30969	27150									
4L48-100	10	900	11.02	99	34808	32839	29602									
4H48-100	10	922	10.02	99	27736	25988	23904	21980	18125							
4H48-100	10	952	11.03	100	28811	27157	25425	23650	20381	14330						
4L48-150	15	996	15.00	102	39160	37622	35673	32417								
4L48-150	15	1022	17.00	103	40300	38857	37027	34137	30575							
4H48-150	15	1058	15.00	103	32404	31264	29752	28105	26493	23717	19846					
4H48-150	15	1088	16.50	104	33414	32408	30914	29562	27643	25800	22880	17025				
4L48-200	20	1097	20.00	105	43574	42385	40879	38985	35906							
4L48-200	20	1117	22.00	105	44444	43318	41863	40063	37228	34001						
4H48-200	20	1161	20.00	105	35863	35117	33765	32418	30889	29316	27431	24675	19222			
4H48-200	20	1196	22.00	106	37033	36308	35116	33769	32548	30651	29598	26685	24326			
4L48-250	25	1180	26.20	107	47175	46207	44863	43327	41319	38457	35297					
4L48-250	25	1206	27.50	107	48298	47352	46092	44660	42964	40178	37228					
4H48-250	25	1250	25.00	107	38833	38140	37181	35881	34665	33161	31678	30405	27518	19085		
4H48-250	25	1293	27.50	108	40277	39592	38812	37555	36332	35202	33313	32339	30311	23911		
4L48-300	30	1251	31.30	108	50239	49327	48207	46908	45313	43114	40414	37395				
4L48-300	30	1283	33.00	108	51617	50727	49702	48436	46968	45171	42539	39770				
4H48-300	30	1328	30.10	109	41453	40771	40119	38908	37684	36577	35031	33683	32735	27759	18583	
4H48-300	30	1375	33.00	109	43028	42351	41720	40710	39528	38408	37345	35469	34553	30470	22859	
4L48-400	40	1373	40.00	110	55479	54647	53819	52693	51509	50071	48381	45921	43432			
4L48-400	40	1430	44.10	111	57965	57119	56321	55362	54225	52998	51568	49629	47267			
4H48-400	40	1463	40.10	111	45969	45296	44703	44050	42939	41828	40791	39792	38060	36180	31640	23814
4H48-400	40	1509	44.10	111	47501	46830	46256	45681	44702	43625	42568	41600	40389	37957	34373	30148

Performance shown is for installation type B: free inlet, ducted outlet. Power rating (BHP) does not include drive losses. Performance ratings do not include the effects of appurtenances in the airstream.

The sound power level ratings shown are in decibels, referred to 10⁻¹² watts calculated per AMCA Standard 301. Values shown are for inlet L_{wi}A sound power levels for installation type B: free inlet, ducted outlet. Ratings do not include the effects of end correction.

* Sound power values shown are at the peak cataloged pressure for each RPM.

TBI-FS 54 Level 3 Belt Drive



Shown with Optional Brackets

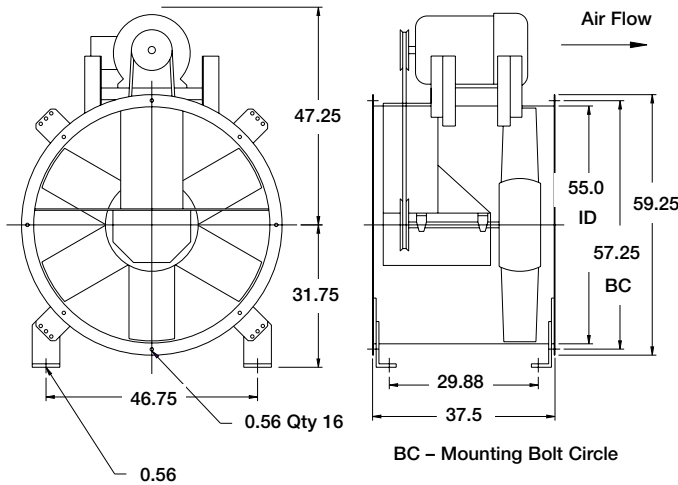

Specifications

- Max FRPM - L = 848
- Max FRPM - H = 999
- Max Motor Frame size = 256T
- Shaft Diameter = 2 in.
- Fan Tube Gauge = 10 ga.
- Approx. Weight (Steel) = 665 lbs.

Outlet Velocity (FPM) = CFM/16.5 ft²
Tip Speed = FRPM x 14.1

Performance Data - Level 3

Optimum selection for propeller type shown in bold. Refer to page 3 for sound pressure corrections.

Model Number	Motor HP	Fan RPM	Max BHP	* L _{wi} A	CFM / Static Pressure in Inches WG											
					0.125	0.250	0.375	0.500	0.625	0.750	0.875	1.000	1.125	1.250	1.375	1.500
					CFM	CFM	CFM	CFM	CFM	CFM	CFM	CFM	CFM	CFM	CFM	CFM
3L54-20	2	423	2.01	83	25121	20981										
3L54-20	2	437	2.21	84	26074	22293										
3H54-20	2	495	2.00	86	22938	21171	17185									
3H54-20	2	512	2.21	87	23845	22179	18586									
3L54-30	3	482	3.00	87	29119	26601	22325									
3L54-30	3	498	3.30	88	30202	28046	23812									
3H54-30	3	567	3.01	90	26747	25260	23383	19427								
3H54-30	3	586	3.31	92	27719	26288	24717	21047								
3L54-50	5	572	5.00	92	35169	33734	30875	27215								
3L54-50	5	592	5.54	92	36502	35102	32731	29084	23368							
3H54-50	5	670	5.00	94	31995	30828	29608	28140	24709	21567						
3H54-50	5	694	5.52	96	33210	32116	30914	29580	26930	23755						
3L54-75	7½	654	7.55	95	40615	39309	38107	35016	31768	26558						
3L54-75	7½	673	8.27	96	41870	40592	39420	36831	33569	30063						
3H54-75	7½	767	7.52	98	36893	35999	34860	33826	32539	30200	27184	24309				
3H54-75	7½	789	8.27	98	38000	37160	36053	35025	33851	32025	28940	26296	23563			
3L54-100	10	715	10.00	97	44671	43435	42306	40623	37552	34664	30175					
3L54-100	10	744	11.03	98	46641	45388	44283	43193	40401	37408	34824	28711				
3H54-100	10	842	10.01	100	40661	39879	38907	37891	36967	35752	33756	30821	28364	25778		
3H54-100	10	871	11.13	101	42114	41358	40458	39455	38554	37479	36114	33352	30929	28379	25933	
3L54-150	15	819	15.03	101	51710	50408	49358	48397	47160	44628	41842	39416	35763			
3L54-150	15	848	16.54	101	53662	52339	51325	50378	49451	47266	44631	42152	39895	34927		
3H54-150	15	964	14.84	105	46765	46082	45389	44483	43578	42771	41854	40787	39033	36262	34280	31992
3H54-150	15	999	16.43	108	48511	47852	47193	46357	45482	44669	43890	42877	41848	39739	37063	35171

Performance shown is for installation type B: free inlet, ducted outlet. Power rating (BHP) does not include drive losses. Performance ratings do not include the effects of appurtenances in the airstream.

The sound power level ratings shown are in decibels, referred to 10⁻¹² watts calculated per AMCA Standard 301. Values shown are for inlet L_{wi}A sound power levels for installation type B: free inlet, ducted outlet. Ratings do not include the effects of end correction.

* Sound power values shown are at the peak cataloged pressure for each RPM.

Shown with Optional Brackets

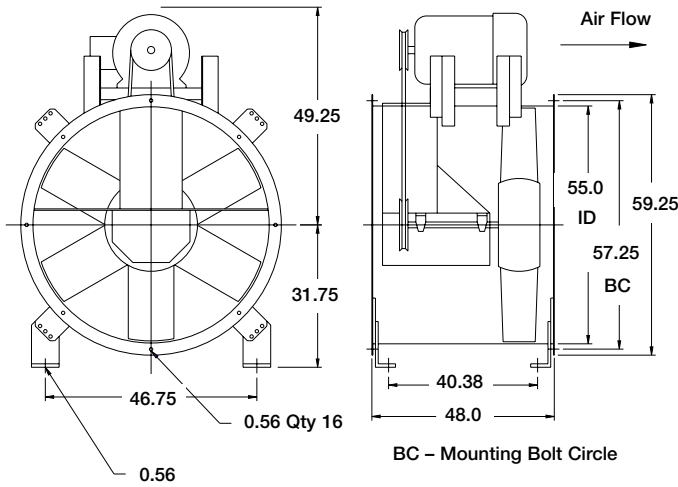

Specifications

- Max FRPM - L = 1189
- Max FRPM - H = 1337
- Max Motor Frame size = 326T
- Shaft Diameter = 2 3/16 in.
- Fan Tube Gauge = 3/16 in.
- Approx. Weight (Steel) = 1050 lbs.

Outlet Velocity (FPM) = CFM / 16.5 ft²
Tip Speed = FRPM x 14.1

Performance Data - Level 4

Optimum selection for propeller type shown in bold. Refer to page 3 for sound pressure corrections.

Model Number	Motor HP	Fan RPM	Max BHP	* L _{wi} A	CFM / Static Pressure in Inches WG											
					0.500	0.750	1.000	1.250	1.500	1.750	2.000	2.250	2.500	3.000	3.500	4.000
					CFM	CFM	CFM	CFM	CFM	CFM	CFM	CFM	CFM	CFM	CFM	CFM
4L54-100	10	675	10.02	95	39677	35485										
4L54-100	10	699	11.51	96	41433	37667	30196									
4H54-100	10	753	10.00	96	32380	30401	26915	21284	15488	12760						
4H54-100	10	784	11.04	97	33917	32286	29089	24635	18438	14826						
4L54-150	15	772	15.02	99	46710	44207	40353									
4L54-150	15	788	16.52	100	47855	45550	41702	34439								
4H54-150	15	868	15.02	100	38044	36951	35013	31928	27960	22639	17789	15422				
4H54-150	15	893	16.51	101	39264	38202	36537	33661	30391	25407	19492	17076	14776			
4L54-200	20	849	20.03	101	52375	50227	47354	43927								
4L54-200	20	867	22.02	102	53722	51539	48979	45441	38121							
4H54-200	20	954	20.04	103	42311	41233	40199	38136	35195	31879	27089	21678	18827			
4H54-200	20	981	22.02	104	43664	42566	41600	39791	37064	34289	30018	25310	20562			
4L54-250	25	903	25.08	104	56401	54149	52018	48683	41822							
4L54-250	25	934	27.51	105	58694	56382	54597	51551	48454	40918						
4H54-250	25	1027	25.07	105	45960	44828	43905	42577	40517	37776	34721	30382	25884	19446		
4H54-250	25	1056	27.54	106	47401	46248	45350	44313	42449	39786	37299	33494	29120	21332	17441	
4L54-300	30	960	30.04	105	60609	58246	56509	53926	50636	43606						
4L54-300	30	993	33.02	107	63028	60624	58921	56763	53685	50996	43171					
4H54-300	30	1096	30.05	107	49384	48200	47335	46470	44888	42771	40251	37427	33476	24212	20127	
4H54-300	30	1128	33.02	107	50965	49789	48916	48076	46819	45074	42470	40261	36879	28690	22225	18583
4L54-400	40	1069	40.03	109	68292	66329	64422	62862	60594	57655	55148	47431				
4L54-400	40	1106	45.59	110	70789	69081	67077	65569	63713	61076	58260	51228	47826			
4H54-400	40	1198	40.04	109	54411	53304	52357	51566	50774	49343	47687	45155	43080	36391	28225	23247
4H54-400	40	1241	44.02	111	56562	55451	54460	53696	52932	51926	50339	48367	46090	40961	33517	26017
4L54-500	50	1139	50.10	110	73012	71523	69433	67969	66468	64089	61281	58930	51254			
4L54-500	50	1189	55.13	110	76375	75203	73195	71582	70179	68347	65902	63212	61134			
4H54-500	50	1289	50.03	112	58955	57840	56810	56063	55327	54591	53250	51723	49543	45300	38769	31376
4H54-500	50	1337	55.01	113	61340	60219	59227	58419	57710	57001	56126	54655	53137	48925	46882	36972

Performance shown is for installation type B: free inlet, ducted outlet. Power rating (BHP) does not include drive losses. Performance ratings do not include the effects of appurtenances in the airstream.

The sound power level ratings shown are in decibels, referred to 10⁻¹² watts calculated per AMCA Standard 301. Values shown are for inlet L_{wi}A sound power levels for installation type B: free inlet, ducted outlet. Ratings do not include the effects of end correction.

* Sound power values shown are at the peak cataloged pressure for each RPM.

Model TBI-FS Axial Inline - Belt Drive

Inline fans shall be of the axial type with fabricated steel airfoil propellers.

The housing shall be constructed of continuously welded steel to assure no air leakage and include integral punched inlet and outlet flanges. The housing, bearing support, and motor base shall be constructed of structural members to prevent vibration and rigidly support the shaft, bearings, and motor.

Steel housings, propellers, and structural components to be coated with Permator®[®], an electrostatically applied thermosetting polyester urethane. Minimum thickness to be 1.5 to 2 mils.

Impeller blades shall be airfoil design. Blade gussets shall be die formed and welded to the blade stem. Propellers to be statically and dynamically balanced. A standard square key or tapered bushing shall lock the rotor to the fan shaft.

Bearings shall be cast iron pillow block, grease lubricated and self aligning. Bearings shall be Air Handling quality and tested for reduced swivel torque, bore size, noise, and vibration. Bearings shall be selected for an L(10) life in excess of 80,000 hours for horizontal applications or an L(10) life of 40,000 hours for vertical applications.

Turned, precision ground and polished steel shafts shall be sized so the first critical speed is at least 25% over the maximum operating speed for each level of construction.

TBI-FS fans shall be licensed to bear the AMCA Seal for Sound and Air Performance. Fan shall be UL/cUL listed "Power Ventilators for Smoke Control Systems" when used in emergency smoke applications.

Fans shall be model TBI-FS as manufactured by Greenheck of Schofield, Wisconsin.



Additional Level 5 Specification

Provided with removable straightening vane section fastened to outlet flange. Vanes shall be welded to inner diameter of bolt-on section. Minimum of seven blades constructed of 10 ga material or greater.

Warranty

Greenheck warrants this equipment to be free from defects in material and workmanship for a period of one year from the purchase date. Any units or parts which prove defective during the warranty period will be replaced at our option when returned to our factory, transportation prepaid.

Motors are warranted by the motor manufacturer for a period of one year. Should motors furnished by Greenheck prove defective during this period, they should be returned to the nearest authorized motor service station. Greenheck will not be responsible for any removal or installation costs.

Due to continuing research, Greenheck reserves the right to change specifications without notice.



Number one in air movement and control.



Centrifugal and Vane Axial Fans



Fans and Ventilators



Energy Recovery Ventilators & Make-Up Air Units



Kitchen Ventilation Systems



Dampers and Louvers

Visit the Greenheck website for the most current information available
www.greenheck.com

Greenheck • P.O. Box 410 Schofield, WI 54476-0410 • Phone (715) 359-6171 • Fax (715) 355-2399 • www.greenheck.com