

Inlet and Outlet **DAMPERS** *for Centrifugal Fans*

- **BACKDRAFT DAMPERS**
- **VOLUME CONTROL DAMPERS**
- **NESTED INLET VANES**
- **EXTERNAL INLET VANES**
- **INLET BOX DAMPERS**

*Part of the Greenheck
"Total Centrifugal
Fan Package"*



*Designed, Constructed
and Tested to Match Fan
Capabilities*

 **GREENHECK**

CENTRIFUGAL FAN DAMPERS

GREENHECK CENTRIFUGAL FANS WITH DAMPERS FOR COMMERCIAL AND INDUSTRIAL APPLICATIONS ARE AN UNBEATABLE COMBINATION

Dampers used in conjunction with centrifugal fans provide a simple, reliable and cost effective means for controlling air systems. Complimenting its centrifugal fan line, Greenheck has an extensive offering of dampers for commercial and industrial applications. Who better than a fan manufacturer to design, test and manufacture dampers knowing the conditions that a fan performs under.

- Each centrifugal fan model has a damper that is sized to handle the maximum air velocity.
- No guesswork in trying to match a fan's performance level with a damper's capability.
- Damper designs with centrifugal fans have been optimized to reduce system effect losses.
- Wide variety of types and construction options available means versatility and flexibility in being able to select the best combination for system requirements.
- Dampers are factory tested and inspected before shipping: Fine tuning counter balances; adjustments for linkage and blade operation; setting actuator limits.
- Centrifugal fans and dampers are shipped together as one unit so there is no field mounting required.

The Greenheck "Total Centrifugal Fan Package"

Dampers are just one component of the Greenheck centrifugal fan package. Completely assembled fan and option packages are available including your choice of the following:

- **Structural Bases & Isolators**
- **Motors & Drives**
- **Dampers**
- **Protective Coatings**
- **Variable Frequency Drives**
- **Disconnect Switches**
- **Safety Guards & Weatherhoods**

The package includes as standard long life bearings and a complete vibration analysis.

Contact your Greenheck rep for more information



Outlet Volume Control Dampers

are commonly used in variable air volume systems. Blades are mounted perpendicular to fan shaft for even force loading on the blades and to reduce pressure losses.



Backdraft Dampers

prevent reverse airflow through the system. Recommended to be used on fan Classes I, II, III only.

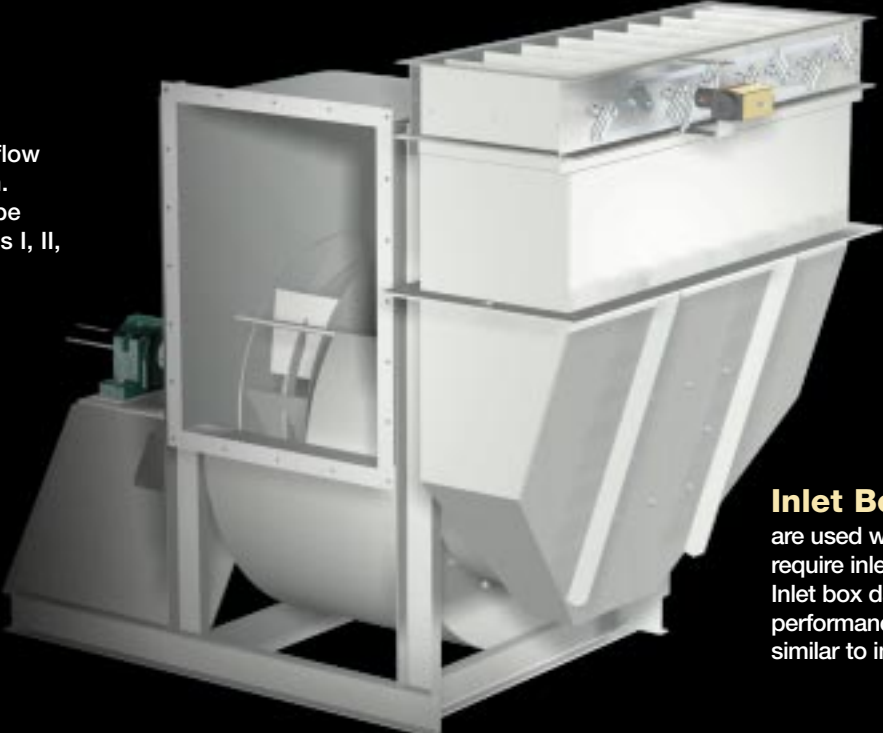

Inlet Box Dampers

are used when applications require inlet boxes. Inlet box dampers have performance characteristics similar to inlet vane dampers.



Nested Inlet Vane Dampers

have linkages incorporated into the housing of the fan. Used in variable air volume applications with space constraints.



External Inlet Vane Dampers

are mounted in the air stream or directly to the fan housing leaving linkages accessible for maintenance. Often used for variable air volume retro-fit applications.

OUTLET DAMPERS

Either backdraft or outlet volume control dampers are available. The type or amount of control required, along with the need for actuators differentiates these models.

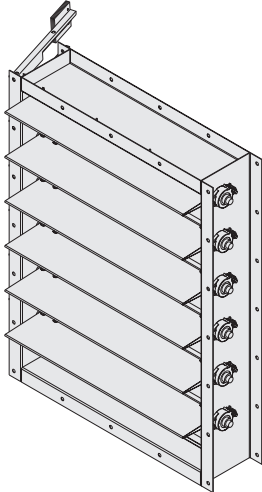

BACKDRAFT DAMPERS

allow air to pass in one direction and restrict flow in the opposite direction. The dampers have gravity actuation with a counter weight and linkage assembly. This is an inexpensive means of keeping air from flowing back through a system. Initial and required maintenance costs are low.

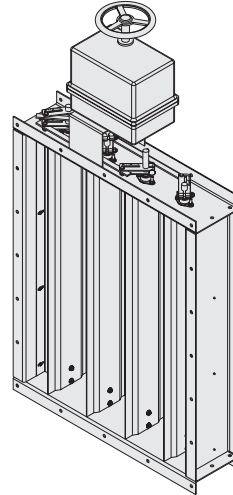

OUTLET VOLUME CONTROL DAMPERS

regulate the airflow by the modulating of damper blades. Actuators may be manual, electric or pneumatic and are mounted out of the air stream. Control dampers are specially designed so blades are all perpendicular to the fan shaft. This feature minimizes pressure losses and distributes the stresses associated with velocity pressures evenly. Both parallel and opposed blade styles are available.

HOW OUTLET DAMPERS AFFECT FAN PERFORMANCE

Where outlet volume control dampers are used, the fan static pressure changes with the resistance produced by modulating or closing the damper blades.

The figure to the right illustrates the performance characteristics of a centrifugal fan with different damper blade positions. Point A shows the performance when the damper is in an open position. Point B illustrates the shift in the operating point as the damper starts to close. For each blade position there will be a new system curve and operating point. The original static pressure (Ps) and brake horsepower (Bhp) curves remain unchanged.

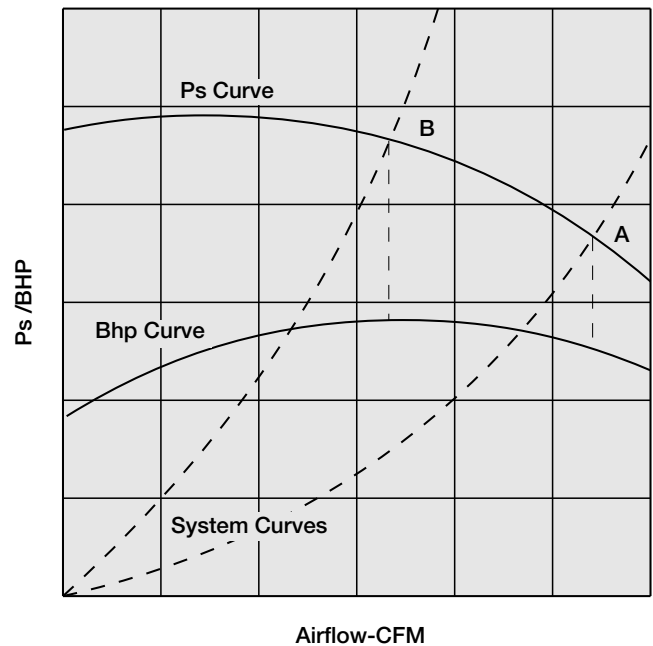

Centrifugal Fan with Outlet Damper

PARALLEL OR OPPOSED?

Control dampers are offered with either parallel or opposed blades. Each style has distinguishing characteristics in regards to control of the fan's performance plus a change in air velocity profile.

- Parallel blade dampers have excellent control over the range of 75% to 100% wide open volume due to the amount of control arm swing required to modulate the blades. Parallel blades are used when greater control is required near the top end of the volume operating range or for systems requiring two position (fully open or fully closed) operation. Parallel blades should not be used upstream of critical components due to uneven airflow.
- Opposed blade dampers offer the best control over the entire operating range. Opposed blades are used for applications where it is necessary to maintain even distribution of air downstream from the damper. This style of blade is the best selection for ducted outlets.

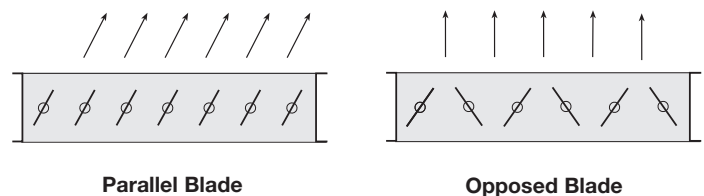

Top View of Blade Action Styles

INLET DAMPERS

Inlet dampers include nested inlet vane, external inlet vane and inlet box dampers. These models save power by reducing Bhp requirements and should be considered when the fan operates for long periods at reduced capacities.

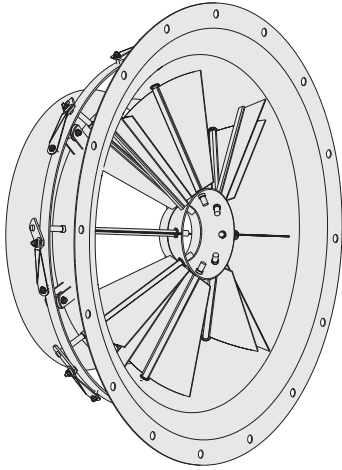

NESTED INLET VANE DAMPERS

are primarily used in non-ducted applications with space constraints. The vanes and linkages are located inside the fan housing with the actuator outside. Recommended for clean air applications only.

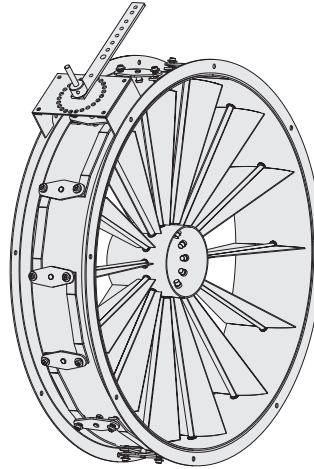

EXTERNAL INLET VANE DAMPERS

are intended for ducted applications and those with higher pressures and velocities. These dampers are mounted in the air stream or directly to the fan housing. Advantages are accessibility to the linkages for maintenance and flexibility in mounting location.

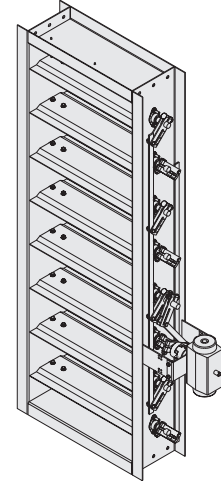

INLET BOX DAMPERS

are used in standard or heavy-duty clean air applications with inlet boxes. These dampers are supplied with parallel blades for performance characteristics similar to inlet vane dampers.

HOW INLET DAMPERS AFFECT FAN PERFORMANCE

Inlet dampers start a pre-spin on air entering into the fan. The pre-spin placed on the entering airflow will be in the same direction as the wheel rotation. This does not allow the wheel to develop its full performance profile, limiting the amount of air flowing through the fan. This pre-spin also reduces the energy requirements of the fan and the overall effect is very similar to reducing the speed on an undamped fan.

Centrifugal fans with inlet vane dampers have different operating points depending on the blade position of the damper. As an inlet damper actuates, open or closed, new operating points are found on the system curve. See the figure to the right. Different operating points are represented by C, D, and E with C the most wide-open and E the least. Each point has a unique static pressure and brake horsepower curve. These points show that by closing an inlet damper, airflow is reduced and less energy is required by the fan.

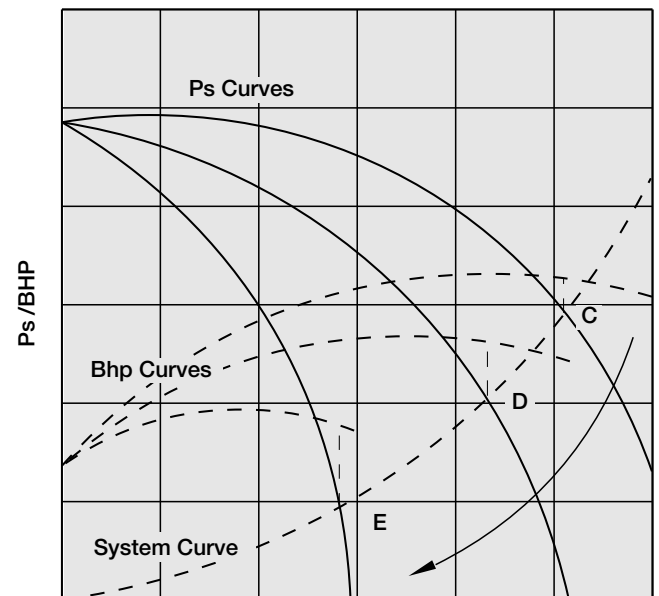

Centrifugal Fan with Inlet Damper

INLET VANE DAMPER

When selecting an inlet vane damper, nested or external, the direction of the air's pre-rotation is critical for proper functioning of the damper and fan combination. Damper rotations are viewed from the air inlet side of the fan, and can be either clockwise (cw) or counter-clockwise (ccw). A fan's rotation is specified from the drive side, not the air inlet side, and will be the opposite of the damper. If the wrong rotation is selected there will be a moderate pressure increase, Bhp will increase significantly, and pulsations may occur.

The graphs below show the effects that blade actuation has on static pressure, Bhp, and cfm with inlet vane dampers and parallel bladed inlet box dampers. Field results may differ from laboratory tested values.

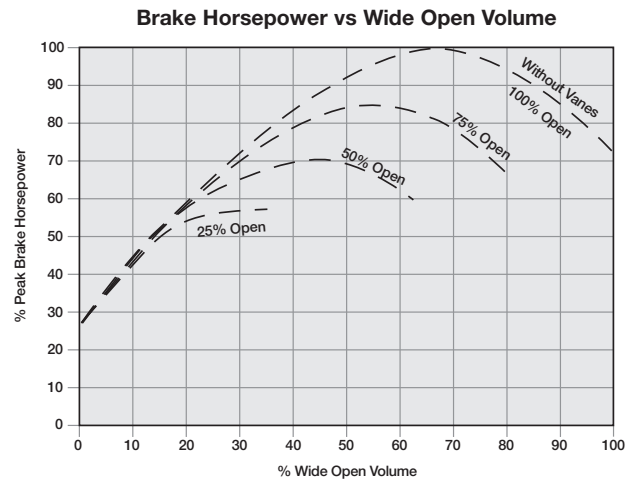
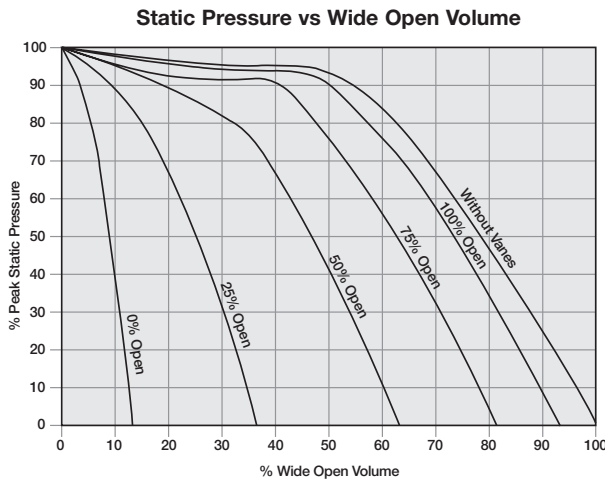

MINIMUM RECOMMENDED ACTUATOR TORQUE FOR INLET VANES (In.-lbs.) for SINGLE WIDTH FANS*

CLASS	FAN SIZE																		
	12	13	15	16	18	20	22	24	27	30	33	36	40	44	49	54	60	66	73
I	26	30	33	38	47	57	68	110	130	140	160	180	270	320	370	430	500	600	700
II	38	43	49	58	73	88	110	160	180	200	230	260	420	490	580	680	800	960	1100
III	54	63	72	86	110	130	160	220	260	280	330	380	620	740	880	1000	1200	1500	1700

*double the value shown for double width fans
*consult factory for class IV applications

DAMPER SELECTION GUIDE

Use the information below to determine which type of damper is appropriate for your application.

- If system backflow is a concern then only outlet dampers should be considered.
- When Variable Air Volumes (VAV) are required either outlet volume control or inlet dampers are the correct choice. To further narrow the selection for VAV system dampers, the fan's efficiency will be better with inlet vane dampers.

After making some of these initial decisions the following chart will help in deciding between damper types.

SELECTION FACTORS	OUTLET DAMPERS			INLET DAMPERS		
	Backdraft Damper	Parallel Blade - Outlet Volume Control Damper	Opposed Blade - Outlet Volume Control Damper	External Inlet Vane Damper	Nested Inlet Vane Damper	Inlet Box Damper
Control Function	Prevents backflow	Good control from 75% to 100% wide open volume *Prevents backflow	Best when used to control the entire operation range	Used in variable air volume systems, provides control the entire operating range		
Airflow downstream from fan	Minor downward direction	Directs air to one side	Distributes air evenly	Pre-spins air before entering fan, no affect on airflow downstream of the fan		
Cost	Low start-up and maintenance costs	Higher initial cost than Backdraft dampers		Increased costs over nested inlet damper	Least expensive inlet dampers	Highest Initial cost
Effect on Horsepower	Unchanged from the original undamped Bhp curve			Decreased Bhp requirements with cfm reduction, provides energy savings		

*Common application for large fans or high static pressures - using a two position actuator

MATCHING DAMPERS WITH FANS

DAMPER TYPES	FAN MODELS						
	Single Width	Double Width	PLG	PLN	SWB	Industrial Process (IPA Only)	TCB TCF
Nested Inlet Vane Damper	YES	YES	NO	YES	NO	NO	YES
External Inlet Vane Damper	YES	NO	NO	NO	YES	NO	NO
Inlet Box Damper	YES	NO	NO	NO	NO	YES	NO
Backdraft Damper	YES	YES	NO	NO	YES	YES	NO
Outlet Volume Control Damper	YES	YES	NO	NO	YES	YES	NO

Where yes is shown, there may be limits on damper availability based on fan class and size. Refer to the Centrifugal and Vane Axial Fan's binder, Engineering tab for Centrifugal Fan/Damper submittals.

CONSTRUCTION

DAMPER TYPES	MATERIAL		TEMPERATURE (MAX)		Ps Max	ACTUATORS		BEARINGS Std
	Std	Opt	Std	Opt		Std	Opt	
Nested Inlet Vane Damper	Steel	None	200° F	-	8.5	Manual Quadrant	Electric Pneumatic Manual Worm Gear	SS Sleeve
External Inlet Vane Damper	Steel	SS	200° F	-	8.5	Manual Quadrant	Electric Pneumatic Manual Worm Gear	SS Sleeve
Backdraft Damper	Galv. Steel	Aluminum 304 SS	180° F	400° F	20	None	None	Ball
Outlet Volume Control	Galv. Steel	304 SS	200° F	400° F	35	Manual Quadrant	Electric Pneumatic Manual Worm Gear	SS Sleeve

Due to continuing product development maximum temperatures and static pressures may change. Inlet box dampers have the same standard and optional construction features as outlet volume control dampers.

A complete line of special coatings are available on all dampers. Consult factory for specific application details or refer to the Coating Engineering Bulletin under the Engineering Data tab in the Centrifugal and Vane Axial Fans binder. Please consult factory for individual requirements.

STANDARD BEARINGS



STAINLESS STEEL SLEEVE



BALL BEARING

ACTUATOR OPTIONS



MANUAL QUADRANT



MANUAL WORM GEAR

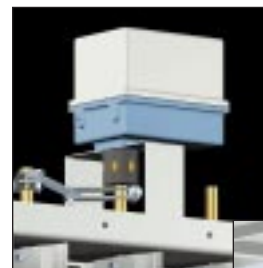

ELECTRIC TWO POSITION OR MODULATING POWER OPEN SPRING RETURN CLOSED

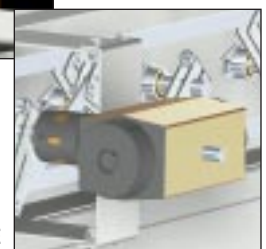

PNEUMATIC WITH MANUAL OVERRIDE

CHECK LIST FOR DAMPERS AND ACTUATORS



DAMPERS

1) Outlet Damper Types:

- Backdraft
- Control Volume - Parallel Blades
- Control Volume - Opposed Blades

Inlet Damper Types:

- Nested
(Specify Fan Rotation: CW, CCW)
- External
(Specify Fan Rotation: CW, CCW)
- Inlet Box Damper

2) Construction Options:

- Actuators (see list for more detail)
- Material (blade & frame)

3) Protective Coatings

ACTUATORS

1) Type:

- Electric
- Pneumatic
- Manual

2) Operation:

- Spring-return power open/power closed (electric)
- Double acting (pneumatic)

3) Operating Mode:

- Two-position
- Modulating

4) Fail Direction

5) Power Supply

6) Control Signal

7) NEMA Enclosure

8) Accessories

Important Note

This brochure is merely an introduction to the dampers available for centrifugal fans. For more specific detail on a particular product or technical information, please refer to the Greenheck damper binder or our website, which contains Acrobat® files of all current Greenheck product literature. If you require further assistance or information please contact your local Greenheck rep or refer to our website (www.greenheck.com) to find your nearest Greenheck rep.

WARRANTY

Greenheck warrants this equipment to be free from defects in material and construction for a period of one year from the purchase date.

Any units or parts which prove defective during the warranty period will be replaced at our option when returned to our factory, transportation prepaid.

Motors are warranted by the motor manufacturer for a period of one year. Should motors furnished by Greenheck prove defective during this period, they should be returned to the nearest authorized motor service station. Greenheck will not be responsible for any installation or removal costs.

Due to continuing research, Greenheck reserves the right to change specifications without notice.



Number one in air movement and control.



Centrifugal and Vane Axial Fans



Fans and Ventilators

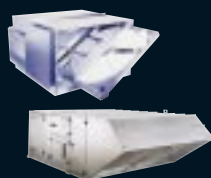

Energy Recovery Ventilators & Make-up Air Units

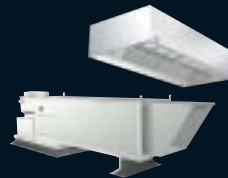

Kitchen Ventilation Systems



Dampers and Louvers

Visit the Greenheck website for the most current information available

www.greenheck.com

Greenheck • P.O. Box 410 Schofield, WI 54476-0410 • Phone (715) 359-6171 • Fax (715) 355-2399 • www.greenheck.com