

MODEL TSU

Make-Up Air Base Unit

Installation, Operation and Maintenance Manual



****WARNING****

Disconnect and secure all electrical power to the "OFF" position prior to inspection or servicing. Failure to comply with this safety precaution could result in serious injury or death.

Improper installation, adjustment, alteration, service or maintenance can cause property damage, injury or death. Read the installation, operating, and maintenance instructions thoroughly before installing or servicing this equipment.

****IMPORTANT****

All factory provided lifting lugs must be used when lifting any unit. Failure to comply with this safety precaution could result in property damage, serious injury or death.

Report any damaged equipment to the shipper immediately!

All units are shipped on a skid or packaged to minimize damage during shipment. The transporting carrier has the responsibility for delivering all items in their original condition as received from Greenheck. The individual receiving the equipment is responsible for inspecting the unit for obvious or hidden damage, recording any damage on the bill of lading before acceptance and filing a claim (if required) with the final carrier. Some accessory items are stored inside the unit during shipping. Care must be taken during installation to prevent damage to units.



TABLE OF CONTENTS

Installation

Housing Size 10 - 30
 Horizontal Discharge3
 Downblast Discharge4
 Housing Size 40 & 50
 Horizontal Discharge6
 Downblast Discharge9
 Filter Section - 40 & 5011
 Weatherhood - 40 & 5011

Electrical12
 Airflow Start-Up13
 Airflow Trouble Shooting14
 Maintenance15
 Maintenance Documentation16

STORAGE

When a fan is not going to be in service for an extended amount of time, certain procedures should be followed to keep the fan in proper operating condition.

- Rotate fan wheel monthly and purge bearings once every three months
- Cover unit with tarp to protect from dirt and moisture (Note: do not use a black tarp as this will promote condensation)
- Energize fan motor once every three months
- Store belts flat to keep them from warping and stretching
- Store unit in location which does not have vibration
- After storage period, purge grease before putting fan into service

If storage of fan is in a humid, dusty or corrosive atmosphere, rotate the fan and purge the bearings once a month. Improper storage which results in damage to the fan will void the warranty.

LIFTING

Greenheck make-up air units must be lifted by the factory supplied lifting lugs only. The unit must also remain upright as shipped, during lifting. **THE USE OF ALL LIFTING LUGS IS MANDATORY WHEN LIFTING.** All access doors and panels must be closed during lifting to avoid damage.

To prevent damage to the unit cabinetry, use *spreader bars*. *Spreader bars* must be in position to stop cables from rubbing the unit frame or panels. Before hoisting into position, test lift to insure stability and balance. Avoid twisting or uneven lifting of the unit. **NEVER LIFT BY THE WEATHERHOOD.**

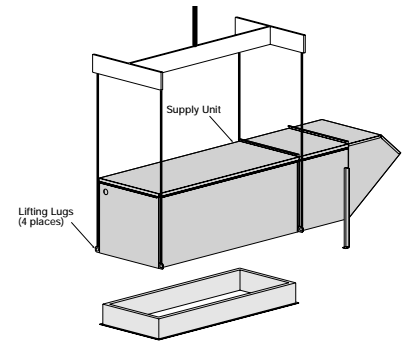

BEFORE BEGINNING THIS INSTALLATION:

Make sure that there is room to access the unit from all sides, recommended service clearance is 3 ft. on all sides. Make sure inlet of unit is located well away from any exhaust fans. When ordered with insulation, this unit has a 0 in. clearance tolerance to any combustibles, on all sides top and bottom. Without insulation, the clearance tolerance is 6 in.

Typical Installations

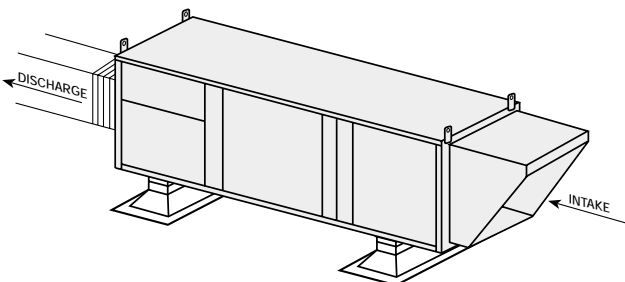

Arrangement HZ shown as roof mounted with weatherhood, mounted on two equipment supports. Ductwork is attached to discharge collar with rubber boot transition.

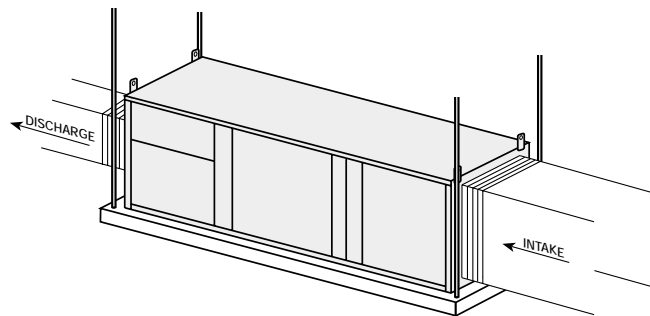

Arrangement HZ shown as an indoor hanging installation with intake and discharge ductwork installed. (Hanging support structure for unit is by others).

Installation Instructions for: TSU Housing Size 10 - 30 Horizontal Discharge Arrangement HZ

Step 1 Mounting the Unit

Arrangement HZ can be mounted on a curb with an equipment support (fig. 1) or on two equipment supports (figs. 2).

Arrangement HZ for indoor applications is built without weatherization and can be mounted hanging, inline as part of an air handling system, or base mounted (see pg. 2). Mounting hardware to be provided by others.

In any case, adequate support of the unit is required.

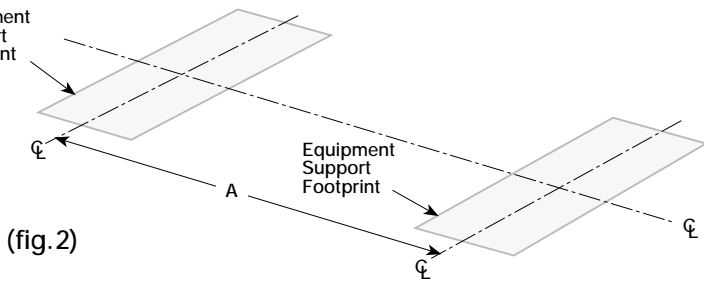
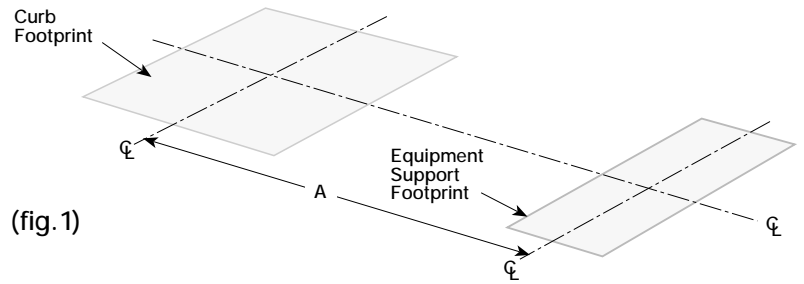

| Housing Size | 10 | 20 | 30 |
|--------------------------------|-----|-----|-----|
| A - Curb Ⓢ to Equip. Support Ⓢ | 76½ | 81½ | 88½ |

All dimensions shown in inches.

Step 2 Attach Ductwork to Unit Discharge

Chart and drawing (fig.3) below shows opening size (ID) and location for a discharge collar. Also included is the recommended straight duct lengths for optimal performance. Greenheck recommends attaching ductwork to collar using a rubber duct section at the unit to eliminate vibration.

Step 3 Attach Ductwork to Unit Intake (If Required)

Chart and drawing (fig.4) below shows dimensions for intake opening (ID). Attach ductwork to perimeter flange using a rubber duct section at the unit to eliminate vibration. Design the remaining ductwork for minimal losses to allow the unit to operate properly.

Recommended Duct Size/Location and Intake Dimensions

| Housing Size | Blower Size | A | B | C | D | E | F | Straight Duct Length* |
|--------------|-------------|-----|----|-----|----|----|----|-----------------------|
| 10 | 108 | 9 | 13 | 8½ | 13 | 26 | 27 | 37 |
| | 109 | 9 | 13 | 8½ | 13 | 26 | 27 | 37 |
| | 110 | 9¾ | 14 | 8 | 14 | 26 | 27 | 47 |
| 20 | 109 | 9 | 13 | 13½ | 13 | 36 | 33 | 37 |
| | 110 | 9¾ | 14 | 13 | 14 | 36 | 33 | 47 |
| | 112 | 10½ | 16 | 12 | 16 | 36 | 33 | 54 |
| | 115 | 12¾ | 20 | 10 | 20 | 36 | 33 | 68 |
| 30 | 112 | 10½ | 16 | 18 | 16 | 48 | 43 | 54 |
| | 115 | 12¾ | 20 | 16 | 20 | 48 | 43 | 68 |
| | 118 | 15¼ | 24 | 14 | 24 | 48 | 43 | 81 |
| | 120 | 14¾ | 26 | 13 | 26 | 48 | 43 | 96 |

*See page 8 for diagram

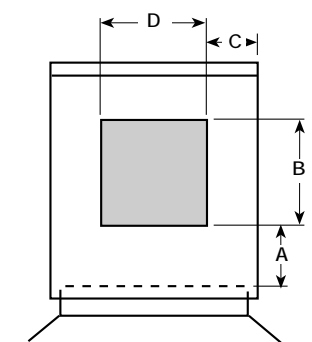

(fig.3)
Discharge Opening

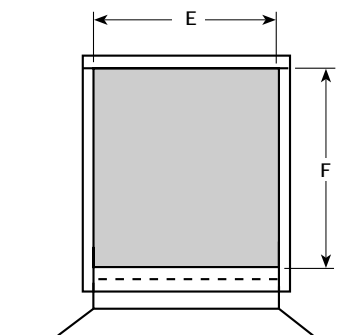

(fig.4)
Intake Opening

Installation Instructions for: TSU Housing Size 10 - 30 Downblast Discharge Arrangement DB

For Installations using square curb and equipment support

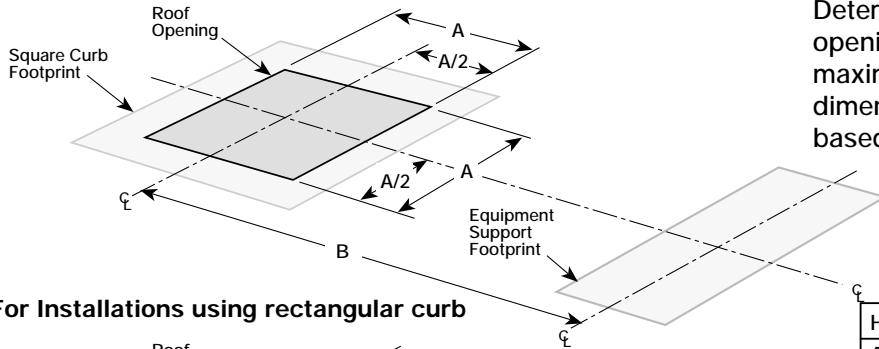

For Installations using rectangular curb

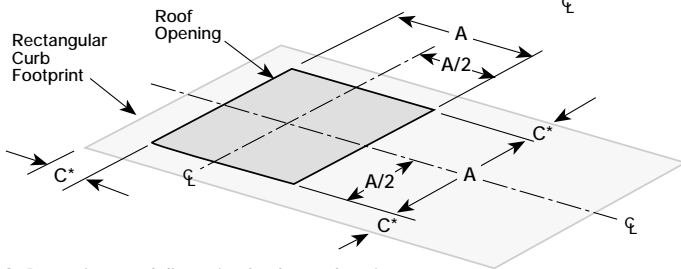

*C- Determine equal dimension for these 3 locations (varies per curb size)

Step 1 Roof Opening

Determine the center of the supply duct roof opening. The chart below shows the maximum recommended roof opening dimensions. These sizes can be smaller based on codes and ductwork sizes.

| | | | |
|---|--------|--------|--------|
| Housing Size | 10 | 20 | 30 |
| A - Max Roof Open. Sq. | 25 | 35 | 47 |
| B - Supply Duct ϕ to Equip. Support ϕ | 76 1/2 | 81 1/2 | 88 1/2 |

All dimensions shown in inches.

Step 2 Install Roof Curb and Equipment Support

For square curbs, center curb over roof opening as shown in first installation diagram at left.

For rectangular curbs, center curb on 3 sides of roof opening, as shown in second installation diagram, by determining C dimension (varies per unit/curb size). For either installation, level the curb and shim if necessary. Attach curb to roof and flash in place.

If equipment support is needed, refer to chart in step 1 for dimensional location based on TSU unit size. Attach to roof in the same manner as the curb. Remove metal cover, flash to wooden nailer, and reinstall cover.

| Recommended Supply Ductwork Sizes | | |
|-----------------------------------|-----------|----------------------|
| TSU Blower Size | Duct Size | Straight Duct Length |
| 108 | 13 x 13 | 37 |
| 109 | 13 x 13 | 37 |
| 110 | 14 x 14 | 47 |
| 112 | 16 x 16 | 54 |
| 115 | 20 x 20 | 68 |
| 118 | 24 x 24 | 81 |
| 120 | 26 x 26 | 96 |

All dimensions shown in inches.

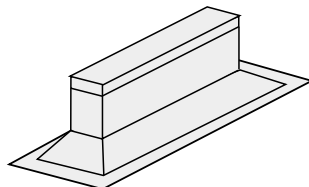
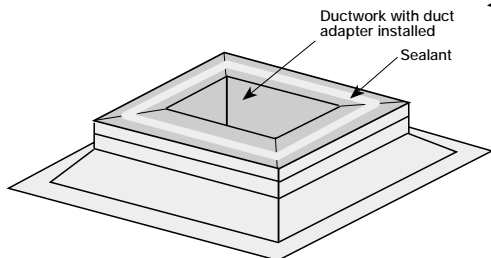
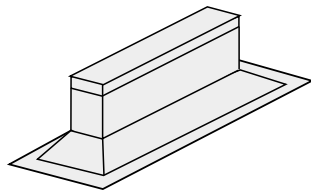
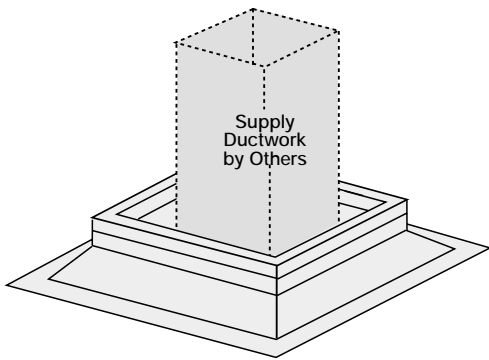

Step 3 Install Ductwork

The chart shows at left shows the duct sizes and straight lengths recommended for optimal performance (AMCA Publication 201-90). Using duct sizes less than recommended lengths will affect fan performance. **Good duct installation practices should be followed for the remaining ductwork.** The use of a duct adapter with the supply duct is strongly recommended to properly align the ductwork with the supply fan discharge. The duct adapter is only a guide and is **not intended to be used as support** for the ductwork.

Step 4 Apply Sealant

Before installing unit apply a sealant or a gasket around the perimeter of the supply duct adapter to isolate the fan and minimize vibration.

Step 5 Install Supply Unit

Use a crane and a spreader bar hooked to the factory lifting lugs (as shown in the diagram) to lift and center the TSU on the curb and equipment support. Use self-tapping sheet metal screws to fasten unit to the curb and equipment support through holes provided.

Electrical and gas lines can be connected at this time.

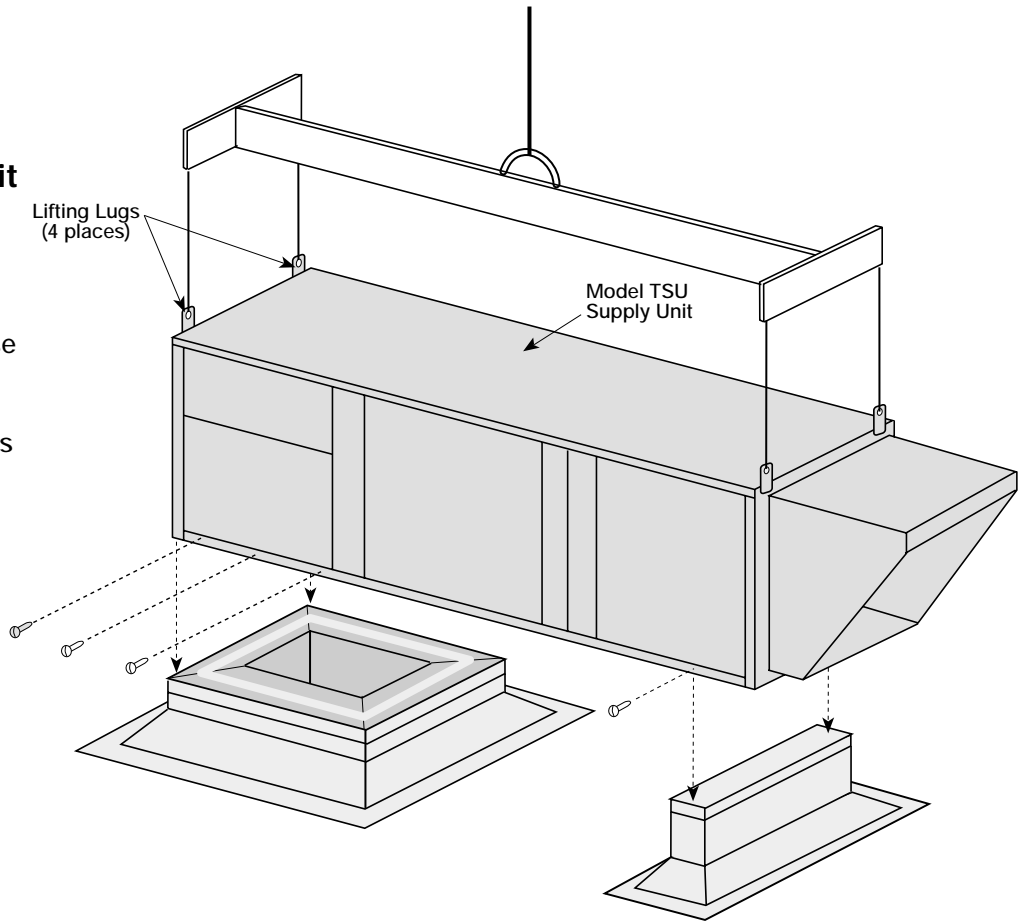

Complete Installation

Illustration shows the complete installation of downblast TSU with filter section and weatherhood.

Figure 5 shows TSU mounted on square curb with equipment support.

Figure 6 is of TSU mounted on rectangular curb.

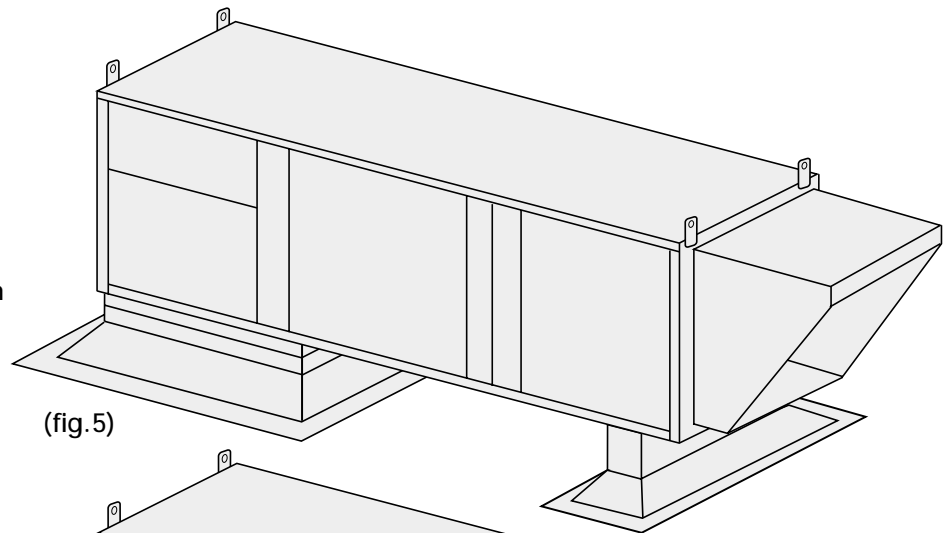

(fig.5)

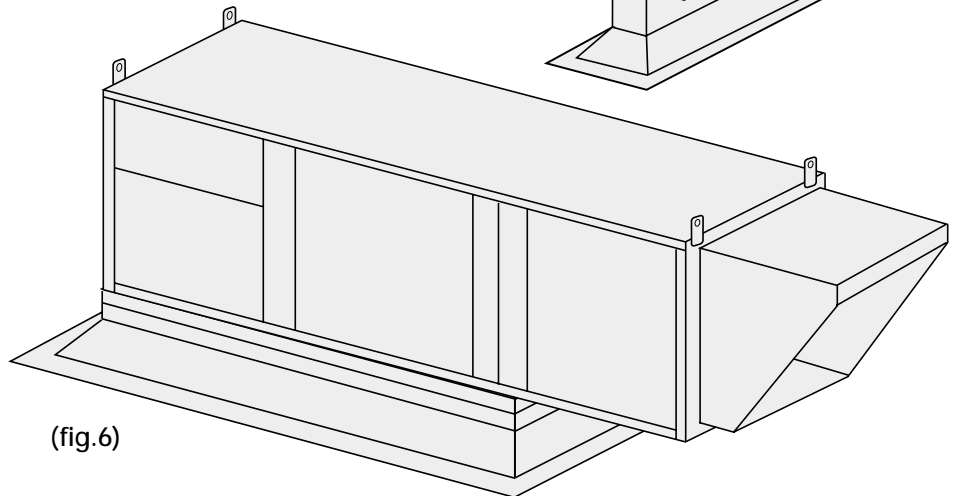

(fig.6)

Installation Instructions for:
SLAB MOUNTING
TSU Housing Size 40 & 50
Horizontal Discharge
Arrangement HZ

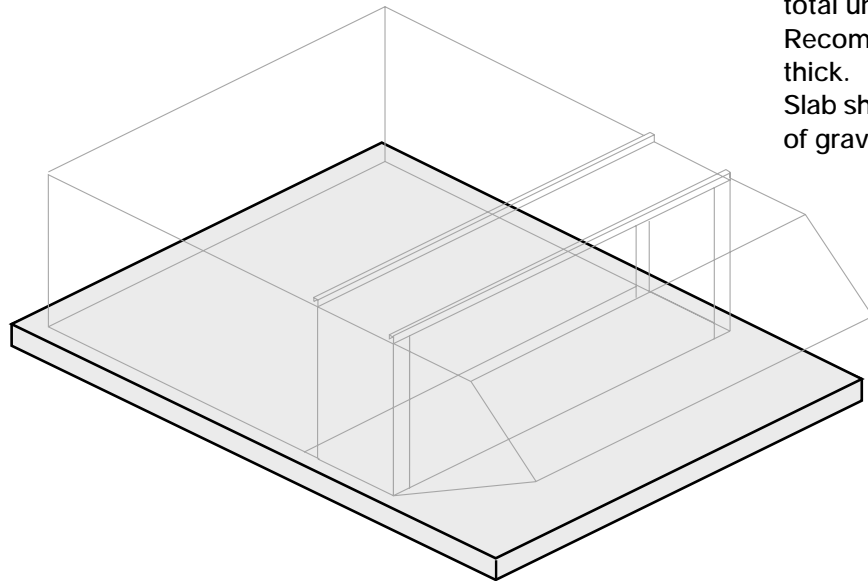

Step 1 Slab Construction

Recommended Size: 1ft. wider and longer than total unit size.

Recommended Material: Concrete at least 4 in. thick.

Slab should be set and leveled on a sufficient bed of gravel for proper drainage.

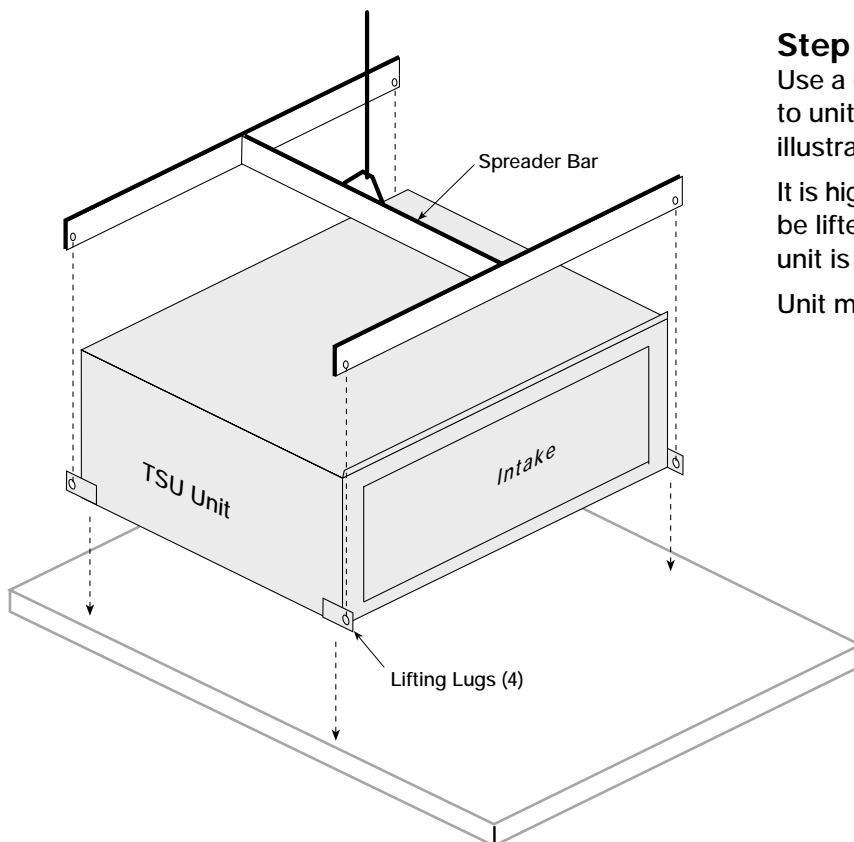

Step 2 Install TSU unit

Use a crane and spreader bar to prevent damage to unit. Lifting lugs are provided as shown in illustration.

It is highly recommended that all accessory items be lifted separately and attached after the TSU unit is in place (see pg. 11).

Unit may be fastened to slab through lifting lugs.

**Installation Instructions for:
RAIL AND CURB MOUNTING
TSU Housing Size 40 & 50
Horizontal Discharge
Arrangement HZ**

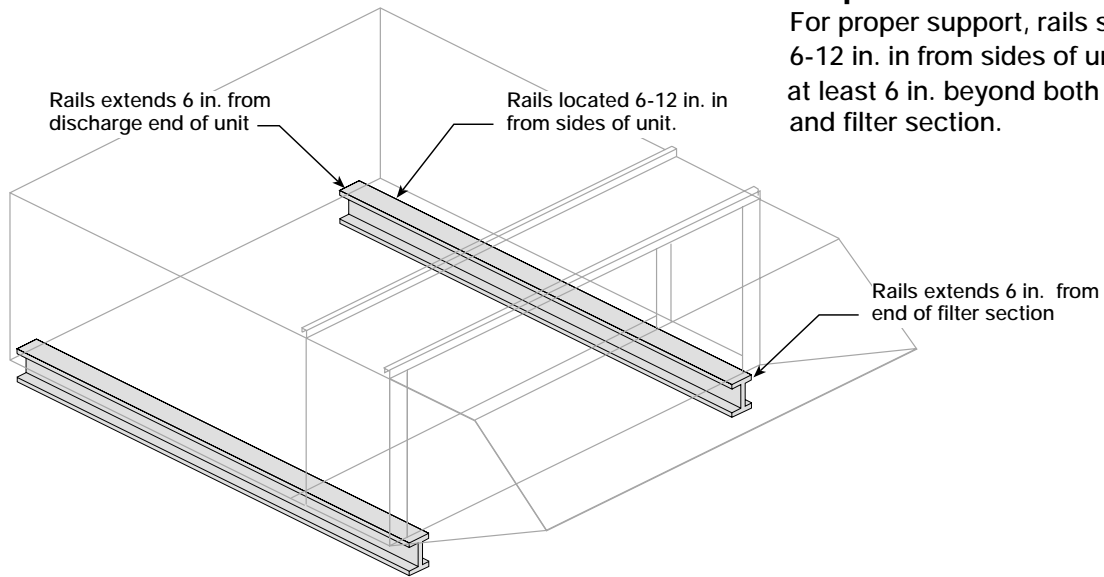

Step 1 Rail Mounting a TSU

For proper support, rails should be located 6-12 in. in from sides of unit and should extend at least 6 in. beyond both discharge end of unit and filter section.

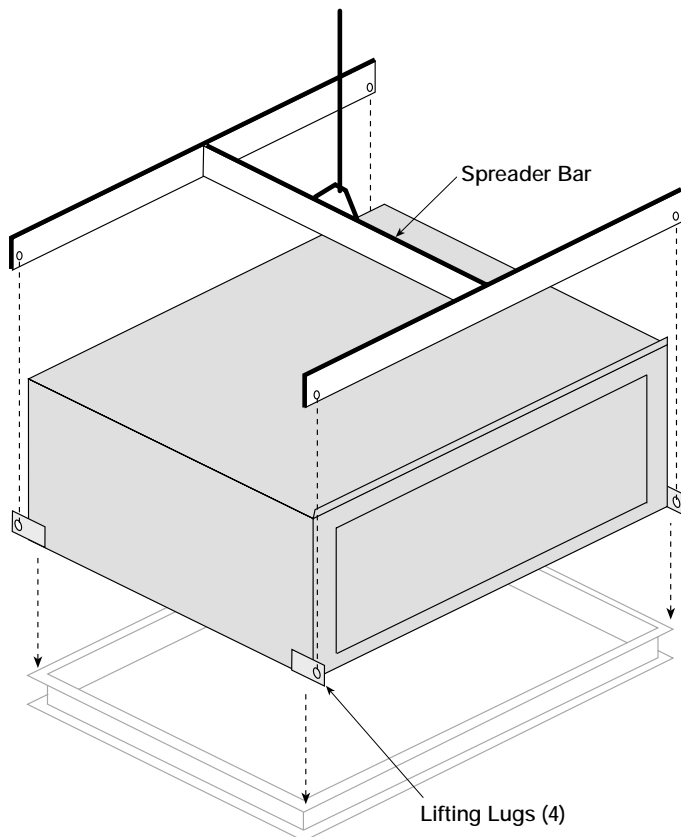

Step 2 Curb Mounting a TSU

Install unit on curb using a crane and spreader bar to prevent damage to unit. Lifting lugs are provided as shown in illustration.

It is highly recommended that all accessory items be lifted separately and attached after the TSU unit is in place (see pg. 11).

Step 3 Attach Ductwork to Unit Discharge

The chart and drawings below show opening size (ID) and location for discharge collar. Also included is the recommended straight duct lengths for optimal performance. Greenheck recommends attaching ductwork using a rubber duct section at the unit to eliminate vibration.

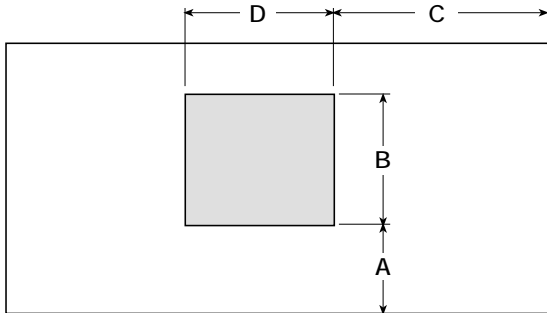

Housing Size 40
Blower Size 120
Discharge Openings

Unit End View

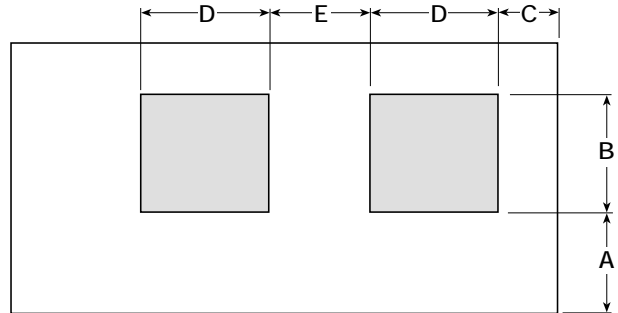

Housing Size 40 and 50
Blower Sizes 218 - 230
Discharge Openings

Opening Sizes:

| Housing Size | Blower Size | A | B | C | D | E | Filter Section Intake | Unit Intake Size | Straight Duct Length |
|--------------|-------------|--------------------------------|--------------------------------|--------------------------------|--------------------------------|--------------------------------|--|------------------|----------------------|
| 40 | 120 | 16 ¹ / ₄ | 25 ¹ / ₂ | 34 | 23 ¹ / ₄ | | 104 x 48 ¹ / ₂ | 84 x 38 | 96 |
| | 218 | 16 ¹ / ₄ | 19 ⁵ / ₈ | 11 ³ / ₄ | 22 ³ / ₈ | 23 ¹ / ₄ | 104 x 48 ¹ / ₂ | 84 x 38 | 113 |
| | 220 | 16 ¹ / ₄ | 25 ¹ / ₂ | 11 ³ / ₄ | 23 ¹ / ₄ | 21 ¹ / ₂ | 104 x 48 ¹ / ₂ | 84 x 38 | 117 |
| 50 | 225 | 24 ¹ / ₄ | 31 ¹ / ₄ | 15 | 31 ¹ / ₄ | 41 | 149 ³ / ₈ x 63 ⁷ / ₈ | 130 x 51 | 160 |
| | 230 | 24 ¹ / ₄ | 36 ³ / ₄ | 15 | 36 ³ / ₄ | 30 | 149 ³ / ₈ x 63 ⁷ / ₈ | 130 x 51 | 172 |

All dimensions shown in inches

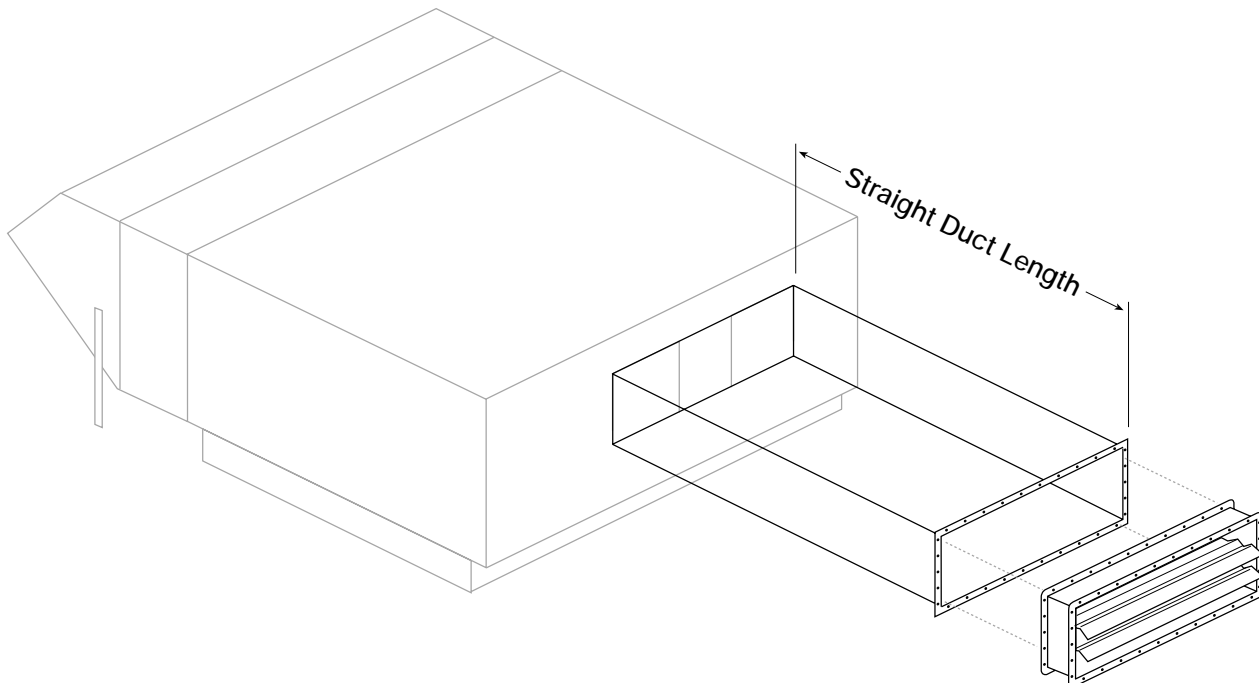

Roof Openings and Curb Sizes TSU Housing Sizes 40 & 50 Downblast Discharge Arrangement DB

Step 1 Assemble Roof Curb.

Curbs are shipped knockdown and require assembly by others. Assembly instructions are included with curb.

Step 2 Locate and Cut Roof Opening

When locating unit, make sure there is room to access unit from all sides. Make sure inlet of this unit is located well away from exhaust fans. When ordered with insulation this unit has 0 in. clearance to any combustibles, on all sides, top and bottom. Without insulation a 6 in. clearance is required.

Step 3 Install Curb

Located curb over roof opening with dimensions shown below and fasten in place.

Recommended Roof Openings :

| Housing Size | Blower Size | A | B |
|--------------|-------------|----|-----|
| 40 | 120 | 36 | 36 |
| | 218 | 36 | 80 |
| | 220 | 36 | 80 |
| 50 | 225 | 42 | 114 |
| | 230 | 47 | 114 |

All dimensions shown in inches

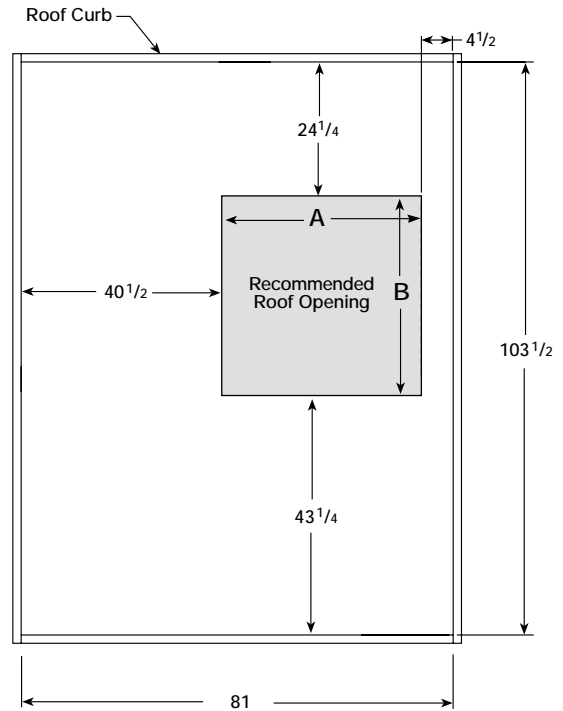

**Roof Opening and Curb
Housing 40, Blower 120**

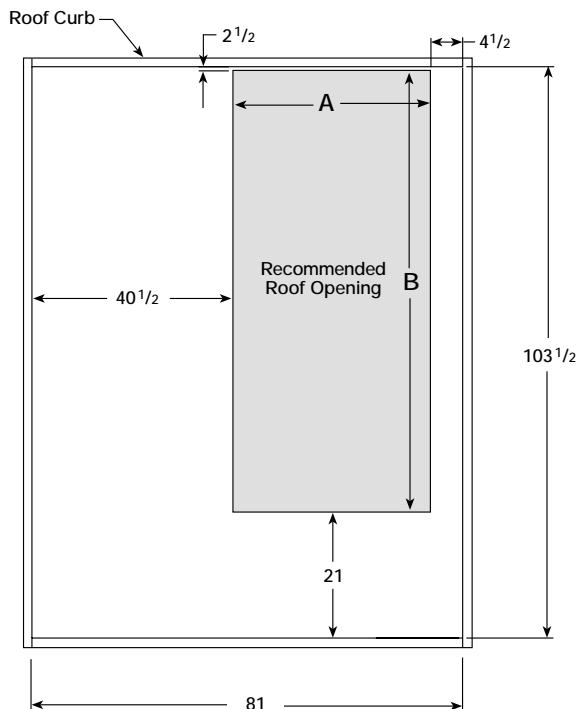

**Roof Opening and Curb
Housing 40, Blower 218 or 220**

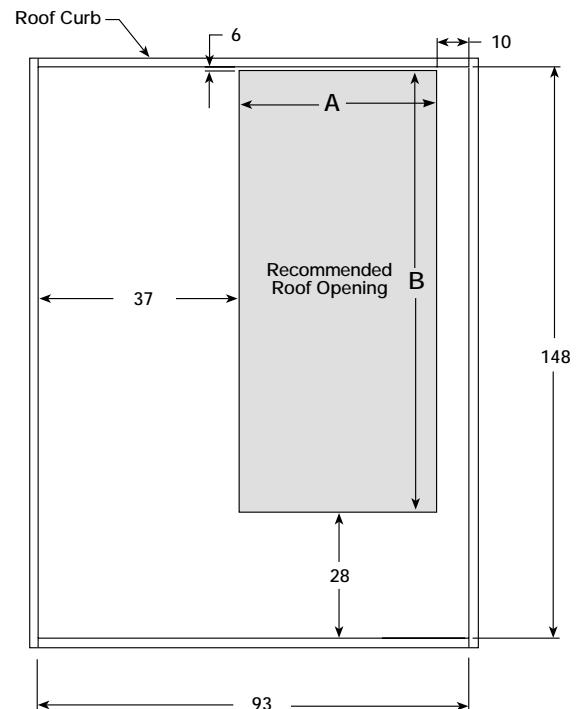

**Roof Opening and Curb
Housing 50, Blower 225 or 230**

Step 4 Install Ductwork

See table on page 8 for the straight duct lengths recommended for optimal performance (AMCA Publication 201-90). Using duct sizes less than recommended lengths will affect fan performance. Good installation practices should be followed for the remaining ductwork.

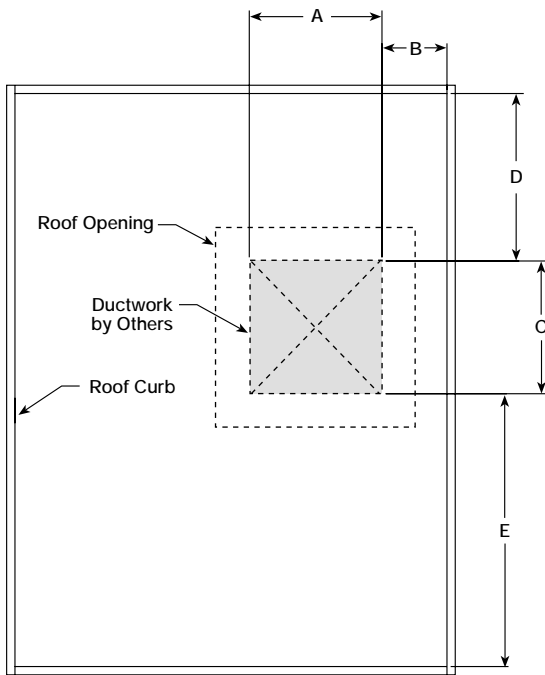

Duct Location for Blower Size 120

| Blower Size | A | B | C | D | E |
|-------------|----|-------------------------------|----|--------------------------------|--------------------------------|
| TSU-120 | 26 | 9 ¹ / ₂ | 26 | 29 ¹ / ₄ | 48 ¹ / ₄ |

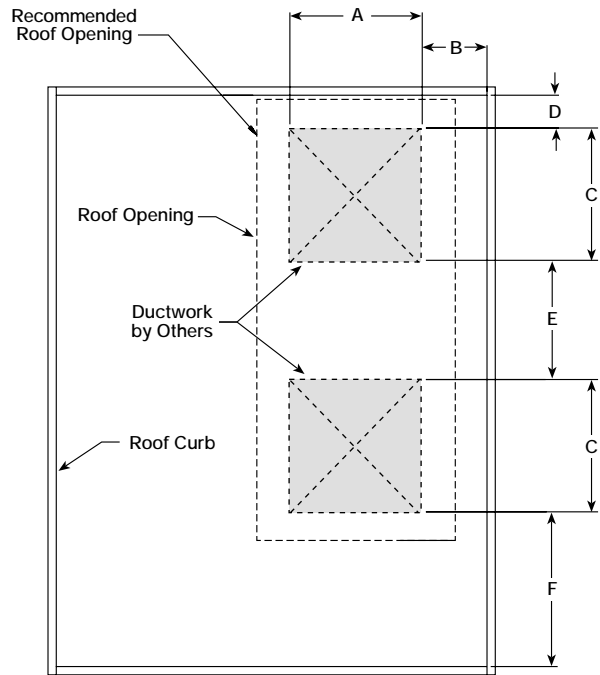

Duct Locations for Blower Sizes 218-230

| Blower Size | A | B | C | D | E | F |
|-------------|--------------------------------|--------------------------------|--------------------------------|----|--------------------------------|--------------------------------|
| TSU-218 | 24 | 11 ¹ / ₂ | 24 | 7 | 22 ³ / ₄ | 26 |
| TSU-220 | 26 | 9 ¹ / ₂ | 26 | 7 | 18 ³ / ₄ | 26 |
| TSU-225 | 31 ¹ / ₄ | 20 ¹ / ₂ | 31 ¹ / ₄ | 11 | 41 | 33 ¹ / ₂ |
| TSU-230 | 36 ³ / ₄ | 15 | 36 ³ / ₄ | 11 | 30 | 33 ¹ / ₂ |

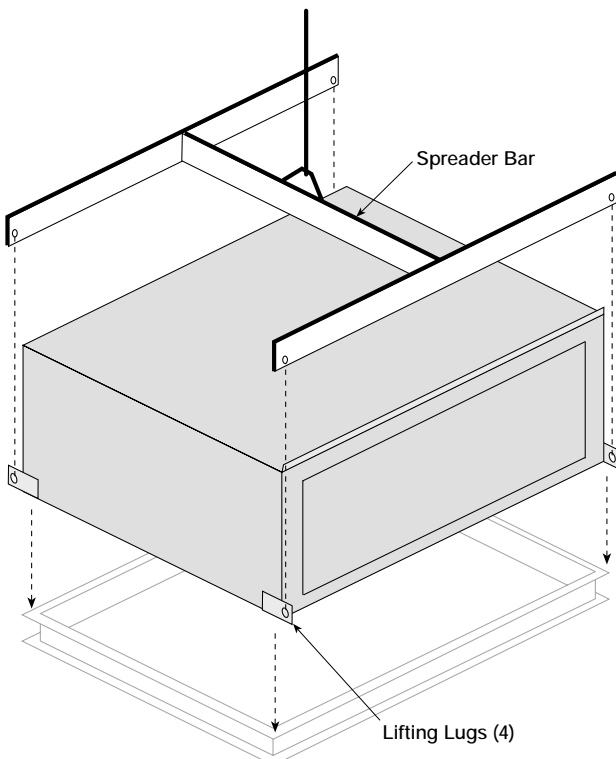

Step 5 Install TSU unit

Use a crane and spreader bar to prevent damage to unit. Lifting lugs are provided as shown in illustration.

It is highly recommended that all accessory items be lifted separately and attached after the TSU unit is in place (see pg.11).

Electrical and gas lines can be connected at this time.

Step 6 Attach filter section (if included)

Use a crane and spreader bar hooked to factory lifting lugs (as shown in diagram) to lift and center the filter section on the TSU unit. Note that the top U-shaped flange on the filter section fits over the vertical flange of the TSU unit (see detail A). Use sheet metal screws to fasten the filter section to TSU unit. Mounting holes are prepunched, see diagram for approx. hole locations.

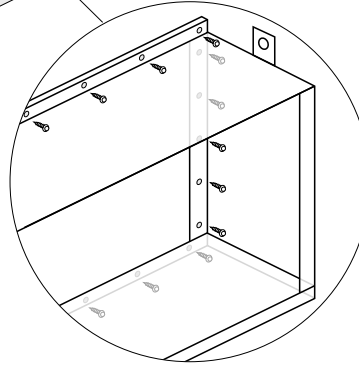
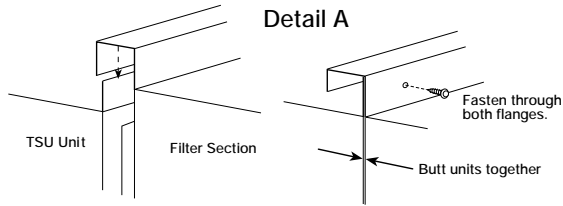
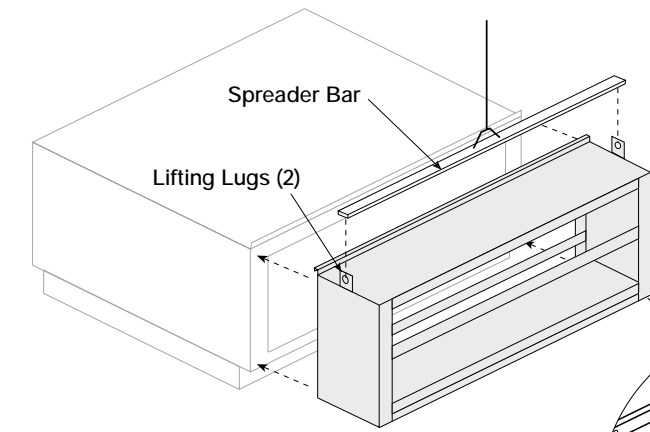

Filters ship separately. To install, remove side panel on filter section and slide into filter channels. Note arrows on filters for correct orientation.

Filter section fastener locations typical for entire section. Top fasteners are accessed from outside, side fasteners are accessed from inside, bottom fasteners are accessed from underneath filter section (Note: bottom fasteners are not required for slab mounted units).

Step 7 Attach Weatherhood

Use a crane and spreader bar hooked to factory lifting lugs (as shown in diagram) to lift and center the weatherhood on the filter section (same procedure as shown in previous step). If there is no filter section, the weatherhood attaches directly to TSU unit in same manner. Fastener instructions are same as Step 6.

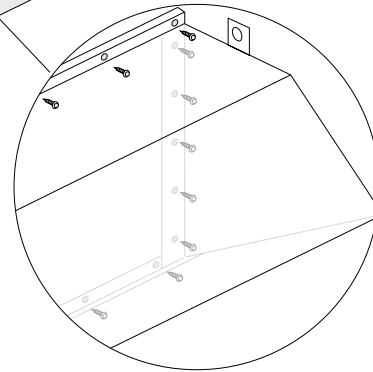
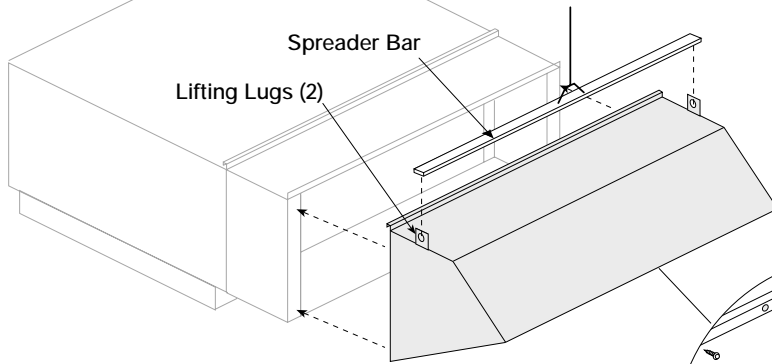

Weatherhood fastener locations typical for entire section. Top fasteners are accessed from outside, side and bottom fasteners are accessed from inside.

Step 8 Attach Support Legs

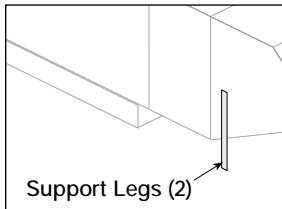

Support Legs are required on weatherhood section. Attach through pre-punched holes in weatherhood using supplied fasteners.

Step 9 Install Birdscreens in Weatherhood

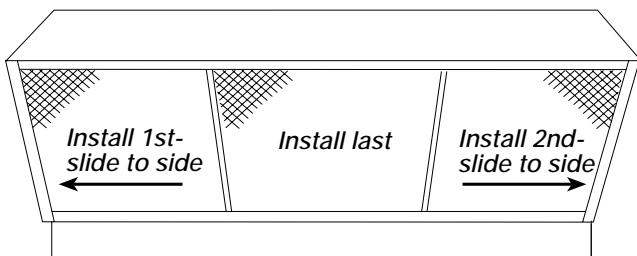

Birdscreens simply slide up and into opening, resting on channels. Install side screens first and slide to edges of unit. Install center screen last. No fasteners are required.

Step 9a Installing Optional Filters in Weatherhood

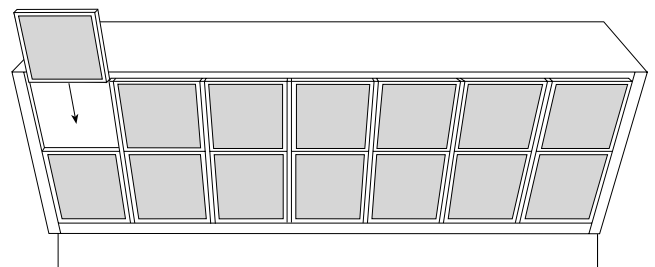

Filters simply slide down into filter tracks as shown. No fasteners are required. Note arrows on filters for correct orientation.

Electrical Instructions

Before connecting power to the unit, read and understand the following instructions and wiring diagrams. Complete wiring diagrams are attached inside the door(s) of the unit.

All wiring should be done in accordance with the National Electrical Code ANSI/NFPA 70- latest edition and any local codes that may apply. In Canada, wiring should be done in accordance with the Canadian Electrical Code. The equipment must be properly grounded.

CAUTION !

If any of the original wire must be replaced, the replacement wire must have a temperature rating of at least 105°C, except for energy cut-off or sensor lead wire which must be 150°C.

DANGER !

High voltage electrical input is needed for this equipment. This work should be performed by a qualified electrician.

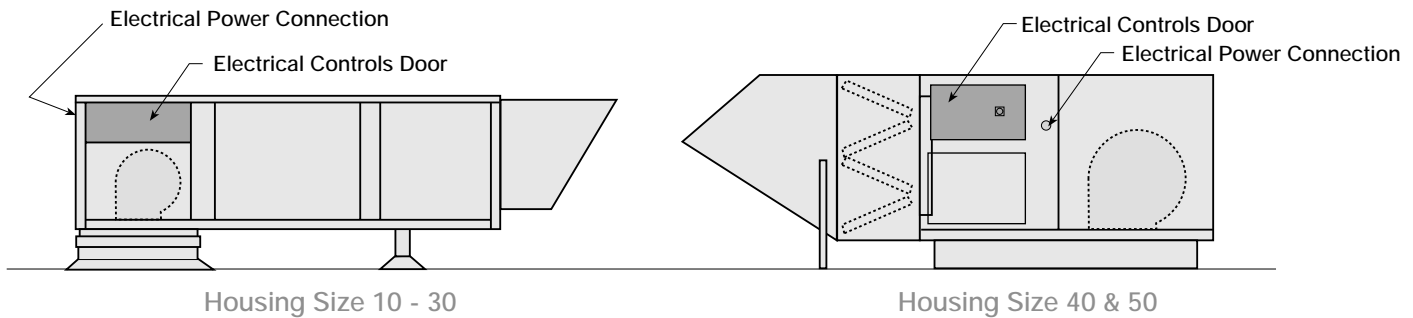

NOTE: Any wiring running through the TSU unit in the airstream must be protected by flexible metal conduit, metal clad cable or raceways.

Sequence for wiring TSU unit:

For units *without* control centers:

The motor nameplate is to be used for determining the voltage and amperage required by the unit. If an electric heater is supplied with the unit, a separate power source may be required for the heater.

For units *with* control centers:

1. The unit's nameplate states the voltage and total amperage required.
The main feeder supplying power to the unit should be sized for the label's voltage and amperage.
2. The main power line should be connected to the disconnect switch.
Make sure that the disconnect lugs are securely tightened.
3. Connect control panel wiring to terminal strip in the control center.
Greenheck's standard control voltage is 120/60/1.
4. Wire any remote temperature selectors (optional) at this time. These wires should be shielded cable if they are to be run with other power wires.
5. When an optional convenience outlet is provided, a separate power supply must be provided to the receptacle. This circuit must be on a ground fault breaker.

CAUTION

Any wiring deviations may result in personal injury or property damage. Greenheck is not responsible for any damage to, or failure of the TSU unit caused by incorrect final wiring.

Airflow System Start-Up

For proper unit function and safety, follow everything in this start-up procedure in the order presented. This to be done after the electrical and gas connections are complete.

Pre-Start Check List

1. Disconnect and lock-out all power switches to fan. See warning below.
2. Check all fasteners, set screws and locking collars on the fan, bearings, drive, motor base and accessories for tightness.
3. Rotate the fan wheel by hand and assure no parts are rubbing.

4. Check the V-belt drive for proper alignment and tension.

Special Tools Required

- Voltage meter
- Incline manometer or equivalent (Direct Gas)
- Tachometer
- Thermometer (Direct Gas)
- Amperage meter

1. Check Voltage

Before starting the unit compare the supplied voltage with the unit's nameplate voltage and the motor voltage.

2. Check Blower Rotation

If the blower is rotating in the wrong direction, the unit will move some air but not perform properly. To check the rotation, open the blower access door and run the blower momentarily to determine the rotation.

To reverse the rotation, turn the power off and use the following procedure:

- For single phase units, rewire the motor per the instructions on the motor.
- For three phase units, interchange any two power leads.

This can be done at the motor starter.

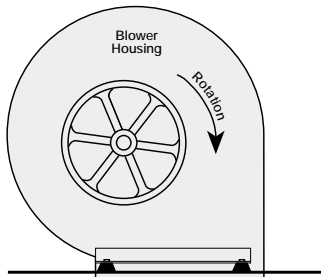

3. Check for Vibration

Check for unusual noise, vibration or overheating of bearings. Excessive vibration maybe experienced during initial start-up. Left unchecked, excessive vibration can cause a multitude of problems, including structural and/or component failure. Many conditions can be discovered by careful observation. If observation cannot locate the source of vibration, a qualified technician using vibration analysis equipment should be consulted. If the problem is wheel unbalance, in-place balancing can be done providing there is access to the fan wheel. Generally, fan vibration and noise is transmitted to other parts of the building by the ductwork. To eliminate this undesirable effect, the use of heavy canvas connectors is recommended. Refer to the "Troubleshooting" section of this manual if a problem develops.

4. Air Volume Check and Measurement

Along with the building balance, the units air volume (cfm) should be measured and compared with its rated air volume. This unit is flexible for varying air volume, but the actual air volume should be known for making final adjustments. The most accurate way to measure the air volume is by using the pitot traverse method in the ductwork away from the blower. Other methods can be used but should be proven and accurate. To adjust the air volume, change the fan rpm or the system losses. See *Trouble Shooting section in this guide.*

5. Measure Motor Voltage, Amperage and Fan rpm

All access doors must be installed except the control center / direct gas controls door. Measure and record the input voltage and motor amperage(s).

To measure the fan rpm, the blower door will need to be removed. Minimize measurement time because the motor may over amp with the door removed.

Compare measured amps to the motor nameplate full load amps and correct if over amping. See the Trouble Shooting section in this guide.

6. Settings for Optional Components

Optional Freeze Protection

This shuts down the blower if the output temperature is below the set point. A timer allows the blower to operate during start-up. This will reset when turned off.

Typical settings are:

Discharge temperature = 45°F

Timer = 5 minutes

Optional 2 Hour Time Delay:

This allows the unit to operate for up to 2 hours after the control panel switch has been turned off. The timer is adjustable.

AIRFLOW TROUBLE SHOOTING

Blower Unit

| Symptom | Possible Cause | Solution |
|------------------------------|--|---|
| Blower fails to operate | Blown fuse or open circuit breaker | Replace fuse or reset circuit breaker and check amps |
| | Broken fan belt | Replace |
| | Defective motor or capacitor | Replace |
| | Motor starter overloaded | Reset starter and check amps |
| Motor overamps | CFMs too high | Check CFMs and adjust drives if needed |
| | Static pressures are higher or lower than design | If higher, ductwork should be improved If lower, fan RPMs should be lower |
| | Blower rotation is incorrect | Check rotation and correct |
| | Motor voltage incorrect | Check motor nameplate and supplied voltage |
| | Motor horsepower too low | See specifications and catalog for fan curves to determine if horsepower is sufficient. |
| | Shorted windings in motor | Replace motor. |
| Insufficient airflow | Unit damper not fully open | Adjust damper linkage or replace damper motor |
| | System static pressure too high | Improve ductwork to eliminate losses using good duct practices |
| | Blower speed too low | Check for correct drives and RPMs with catalog data |
| | Dampers or registers closed. | Open and adjust |
| | Dirty or clogged filters | Clean or replace |
| | Leaks in ductwork. | Repair |
| | Elbows, or other obstructions may restrict fan outlet. | Correct or improve ductwork |
| | Belt slippage | Adjust belt tension |
| Too much airflow | Blower fan speed too high | Check for correct fan RPM |
| | Filter(s) not in place. | Install filters |
| | Insufficient static pressure (SP) (airflow resistance) | Induce SP into system ductwork. |
| Excessive noise or vibration | Wheel rubbing on housing | Center wheel |
| | Loose wheel on shaft | Tighten wheel setscrew |
| | Loose motor or blower sheave | Tighten sheave setscrew |
| | Belts too loose | Adjust belt tension after 24 hours of operation |
| | Belts too tight | Loosen to maintain 3/8 in. deflection per ft. of span between sheaves |
| | Worn belt | Replace |
| | Motor base or blower loose | Tighten mountings bolts |
| | Worn bearings | Replace |
| | Bearing and drive alignment | Realign |
| | Motor out of balance | Replace |
| | Wheel out of balance | Replace or rebalance |
| | Sheaves eccentric or out of balance | Replace or rebalance |
| | Accumulation of material on wheel | Clean wheel and housing |

MAINTENANCE

Greenheck recommends these procedures to insure trouble free operation of this unit. It is especially important to maintain heater units for clean and efficient operation. Most unit failures can be attributed to poor setup or poor maintenance.

A record of maintenance performed on this unit should be kept. This information will provide essential information if problems are encountered. A section at the back of this manual is provided for recording the unit's maintenance history.

CAUTION: When performing any maintenance on this unit be sure that the power is disconnected and cannot be accidentally turned on. The control center disconnect can be locked in the off position .

2 weeks after startup

Check belt tension - Belts tend to stretch after a period of time. They should be periodically checked for wear and tightness. **Approximately $\frac{3}{8}$ in. of deflection per ft. of span between sheaves is standard for belt tightness.** When replacing belts, use the same type as supplied with the unit. Matched belts should always be used on units with multigroove pulleys.

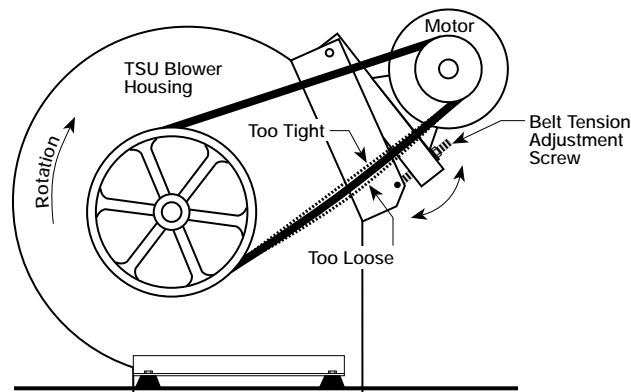

NOTE: For motors of 1 hp or less a smaller sliding base bracket is used to attach to blower.

Replacement of belts - should be accomplished by loosening the tensioning device to the point where the belts can be removed by hand. Do not force belts on or off as this may cause breakage of cords leading to premature belt failure. Belts should be adjusted as above.

Every 3 Months

The filter in the unit should be inspected at least every 3 months. Depending on the environment filters could require changing or cleaning more or less often. The filters can be slid out of either side of the unit.

If **washable filters** are installed, they can be washed in warm soapy water. An adhesive spray can be applied to increase filter efficiency.

If **disposable filters** are installed, check by holding up to a light source. If light cannot pass through the filter, it should be replaced. Replacement filters should be of the same manufacturer and size.

When reinstalling filters, be sure to install with the airflow in the correct direction indicated on the filter and with any factory spacers that came with the unit.

Yearly

All **bearings** on units 108 to 118 are permanently lubricated and require no further lubrication under normal use. Normal use being considered -20°F to 120°F and in a relatively clean environment. Units from sizes 120 to 220 should be checked monthly for lubrication.

Motor maintenance is generally limited to cleaning and lubrication (where applicable). Cleaning should be limited to the exterior surfaces only. Removing dust and grease buildup on motor housing assures proper motor cooling. Greasing of motors is intended only when grease fittings are provided. Many fractional motors are permanently lubricated and require no further lubrication. Motors supplied with grease fittings should be greased in accordance with manufacturer's recommendations. When motor temperature does not exceed 104°F (40°C), the grease should be replaced after 2000 hours of running time as a general rule.

Wheels require very little attention when moving clean air. Occasionally oil and dust may accumulate on the wheel causing imbalance. When this occurs the wheel and housing should be cleaned to assure smooth and safe operation. Inspect fan impeller and housing for fatigue, corrosion or wear

Routinely check all **fasteners, set screws and locking collars on the fan, bearing, drive, motor base and accessories** for tightness.

