

Medium Pressure Axial Fans

Models TDI & TBI - Level 4 & 5

with Cast Aluminum Propeller

Direct and Belt Drive

- Clean Air or Fume Exhaust
- Spark Resistant
- Emergency Smoke



Greenheck's inline fans provide the best solution for any application.

MEDIUM PRESSURE AXIAL FANS

Level 4 & 5 medium pressure axial fans are a practical choice for inline applications, ducted or unducted. These models have capabilities best suited for 1 to 3 inches wg (249 - 747 Pa) of static pressure. Multiple levels of construction provide efficient and economical selections for reliable performance in commercial and industrial applications.

Typical applications include:

- General exhaust, supply or return air
- Industrial or commercial space ventilation
- Fume hood exhaust
- Paint booth exhaust
- Emergency smoke exhaust

TBI-CA Standard Features:

- Sizes from 18 - 60 inch (457 - 1,524 mm) propeller diameters
- Volume Range: 1,500 - 96,000 cfm (2,550 - 163,000 m³/hr)
- Static Pressure: Up to 3.25 inches wg (810 Pa)
- Temperatures: Up to 180°F (82°C) Continuous
- Spark Resistance Construction
- Motor and drives out of airstream

TDI Standard Features

- Sizes from 18 - 60 inch (457 - 1,524 mm) propeller diameters
- Volume Range: 700 - 95,000 cfm (1,190 - 161,000 m³/hr)
- Static Pressure: Up to 2.75 inches wg (685 Pa)
- Temperatures: Up to 120°F (50°C) Continuous

TBI-CA / TDI Level 4



TBI-CA / TDI Level 5

Identical to level 4 construction with the addition of a bolt-on straightening vane section. Vane section increases efficiency by 20%.



Leading Edge Support

All Greenheck's products are supported by the industry's best product literature, electronic media, and Computer Aided Product Selection program (CAPS). You'll also find extensive product and Installation and Operation Manual (IOM) information on the Internet.

And, of course, you can always count on the personal service and expertise of our national and international representative organization. To locate your nearest Greenheck's representative call 715-359-6171 or visit our website at www.greenheck.com



GREENHECK
**QUICK
DELIVERY**



Quick Delivery and Quick Build Programs

Greenheck's Quick Delivery (QD) and Quick Build (QB) Programs ensure rapid response time with your needs dictating manufacturing time. Use CAPS or visit www.greenheck.com/qd to determine what programs are available for these products.

Adjustable Pitch Cast Aluminum Propellers

Levels 4 and 5 use heavy duty, cast aluminum airfoil propellers that are designed to meet varied capacity and pressure requirements.

- Hubs are single piece aluminum casting.
- Blade bases are cast around steel stems and allow for manual field adjustment of blade pitch.
- All propellers are dynamically balanced to assure vibration free operation.



Electrostatic Powder Paint

Powder coatings offer a uniform, durable, and high quality finish. Powder coating is a one-coat process applied over a phosphatized surface that meets or exceeds the corrosion resistance of a comparable wet paint.

Greenheck offers a number of in-house coatings applied via “electrostatic powder.” The standard coating, Permator, is excellent for indoor or outdoor applications and also has resistance to many common chemicals. See Greenheck’s Product Application Guides for a complete list of available coatings and their chemical resistance. An updated list is available online at www.greenheck.com.

Maintenance / Serviceable Construction Advantages

The following value added features have been incorporated into the design to allow for quick and easy field service.

- Bearing lubrication is performed through extended grease fittings located on the outside of the fan housing. (Belt drive models only)
- An adjustable motor base is provided for tightening the fan belts. (Belt drive models only)
- Level 5’s bolt-on vane section can be removed to allow access to hub and blades.
- Propellers are easily removed with the use of taper lock bushings.

For additional access to the propeller and internal fan components for field service, see the “Easy Access Construction” option in the Accessories section.



Complete Assembly and Testing

The TBI-CA and TDI fans are completely assembled and tested before shipment. Our inspectors ensure that the fan is vibration free and that they are electrically safe for field operation.

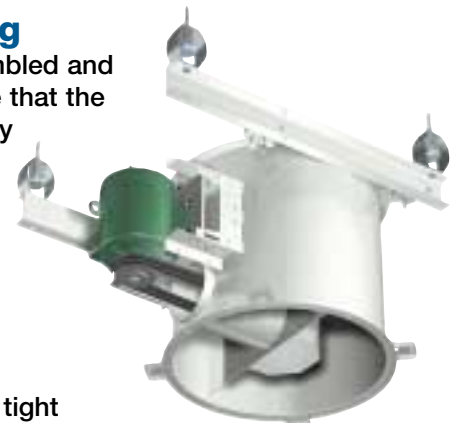

Easy to Install and Operate

The compact designs of the TDI and TBI-CA models helps when fitting into tight spaces. In addition, integral connection punched flanges and optional Universal Mounting brackets accommodate motor position changes for last minute modifications or unexpected installation obstacles. Also available in roof upblast configuration (see pg. 6).

Housing

Housings are continuously welded to prevent air leakage. All steel constructed units are provided with Permator coating. Aluminum construction available upon request.

Inlet & Outlet Flanges

Integral inlet and outlet flanges with mounting holes are provided for an airtight ductwork connection.

Bearings (TBI-CA)

Bearings are air handling quality, grease lubricated, pillow block type. Bearings are selected with a basic rating fatigue life (L10) in excess of 80,000 hours at each fan's maximum operating speed when mounted in a horizontal configuration.

Belt & Bearing Tube (TBI-CA)

Belts, bearings, and drives are protected from the airstream by a heavy gauge steel belt tube and bearing cover.

Adjustable Motor Base (TBI-CA)

Rigid structural steel motor bases are welded to the fan housing and include heavy duty adjustment screws for belt tensioning.

Extended Lube Lines (TBI-CA)

Extended lube lines with grease fittings allow bearing lubrication without disassembling the fan.

Drives (TBI-CA)

Greenheck offers either constant or adjustable speed drives for fan speed adjustments. Belts are static free and oil resistant.

Motors

All motors meet the classification for NEMA design B. Motors are available in open drip proof, totally enclosed, or explosion proof enclosures.

Vane Section (Level 5)

Straightening vanes improve efficiencies 20% by making the air flow more uniform and less turbulent. Additionally this section can be removed to allow access to the fan hub and blade assembly.

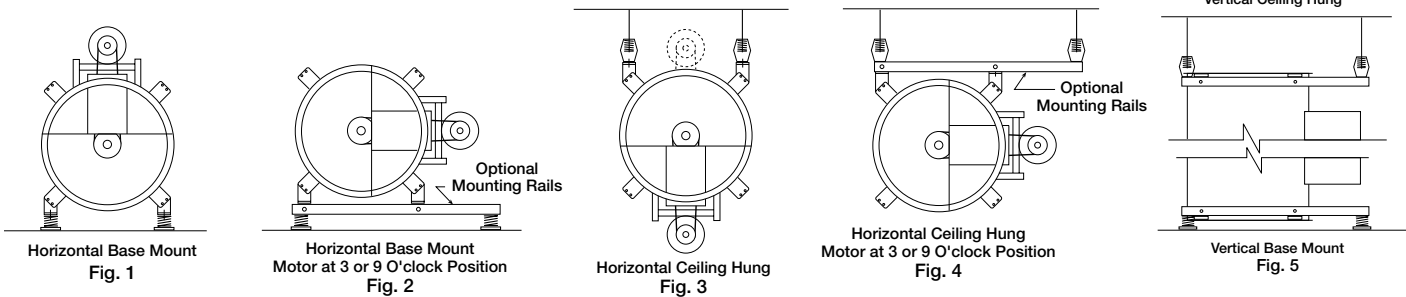

Horizontal and Vertical Mounting Configurations (Brackets Optional)

All axial fans can be mounted horizontally or vertically. For ease of installation, eight optional mounting brackets are welded on each fan. These eight brackets along with mounting supports provide for Greenheck's universal mounting system.

Fig. 1 Horizontal Base Mount

Each fan is shipped as standard in this arrangement. Motor at 12 o'clock is standard.

Fig. 2 Horizontal Base Mount with motor at 3 or 9 o'clock

A set of optional mounting rails are required for this installation. This is the base mounting position required with the easy access option.

Fig. 3 Horizontal Ceiling Hung

In this installation the supports can be positioned for mounting the motor at either 6 or 12 o'clock.

Fig. 4 Horizontal Ceiling Hung with motor at 3 or 9 o'clock

A set of optional mounting rails are required for this installation.

Fig. 5 Vertical Mount

All TBI fans can be mounted vertically (ceiling hung or base mount) for either upward or downward airflow. Optional mounting rails are recommended.

NOTE:

All fans are shown with optional vibration isolators. See the appropriate submittal drawings or installation manual for complete dimensional data.

Emergency Smoke Evacuation

Level 4 and 5 axial fans can be modified to accommodate high temperature process exhaust or emergency smoke and heat relief. The table to the right lists temperature ranges of fan performance. Consult your Greenheck representative.

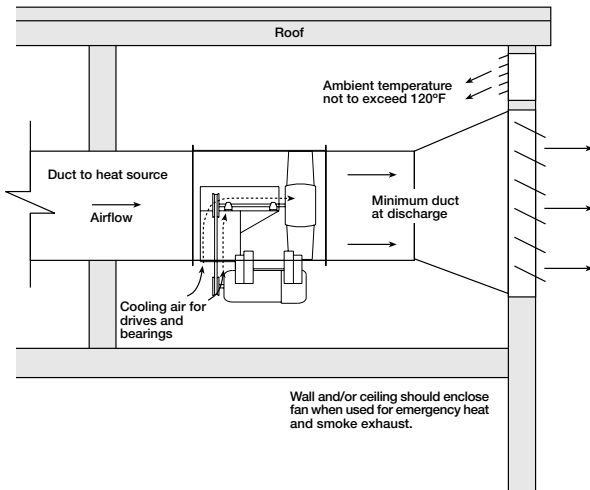

High Temperature Capabilities

Operating Temperature		Time Duration	Drive Type	
F°	C°	Hours	Belt	Direct
120	50	Continuous	Std	Std
300	149	6	✓	✓
392	200	2	✓	✓
482	250	1	✓	✓

✓ Available with high temperature modifications

For the greatest amount of internal cooling, on belt drive models, discharge static pressure should be kept to a minimum while keeping most of the pressure on the inlet side. Locate the fan at ends of the duct runs and near the discharge point in the system. This set-up will promote the ambient air cooling effect.

Model Number Code – The model number system is designed to completely identify the fan.

TDI-4-18-0820-A30			TBI-CA-4 L 36-30		
Tube Axial Inline D - Direct Drive	Motor Horsepower 4 = 1/4 20 = 2 3 = 1/3 30 = 3 5 = 1/2 50 = 5 7 = 3/4 75 = 7 1/2 10 = 1 100 = 10 15 = 1 1/2 150 = 15 200 = 20	Fan RPM A = 1800 B = 1200 C = 900 F = 700	Tube Axial Inline B - Belt Drive	Motor Horsepower 4 = 1/4 20 = 2 200 = 20 3 = 1/3 30 = 3 250 = 25 5 = 1/2 50 = 5 300 = 30 7 = 3/4 75 = 7 1/2 400 = 40 10 = 1 100 = 10 500 = 50 15 = 1 1/2 150 = 15	Fan Size 18, 20, 24, 30, 36, 42, 48, 54, 60
Level of Construction 4,5			Propeller Material CA - Cast Aluminum		
Fan Size 18, 20, 24, 30, 36, 42, 48, 54, 60			Level of Construction 4, 5		
Number of Blades 08,10,12			Propeller Type L - Low Pressure H - High Pressure		
Blade Pitch					

Direct Drive Model Selection

Graph data is based on fan size, level and rpm. The solid black lines are pitch angles for fan blades. Minimum, maximum and five degree pitch intervals are shown. Dashed lines are brake horsepower (Bhp) curves and are labeled to match the corresponding degree pitch of the blade angle.

Starting with the design static pressure (Ps) required, move to the right until the design cfm is reached. The intersection point needs to be between the minimum and maximum blade pitch angles. If the point does not fall on one of the interval curves then the pitch angle should be estimated between the two closest curves. From the Ps and cfm intersection point move vertically until the corresponding Bhp curve is found. The Bhp for the selection is read by moving from this new point to the graph's axis on the right side.

Example: 16,000 cfm @ 0.8 inches Ps wg.

Start at 0.8 inches Ps and move across the graph until intersecting 16,000 cfm, point A. The pitch is 15°. Find the 15° Bhp curve and move vertically downward from A to the intersection, B. From point B, read the Bhp required for this point of operation, C or 4.5 horsepower.

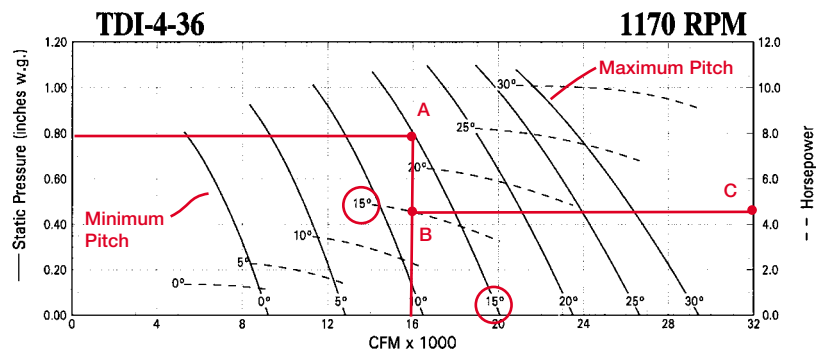

Belt Guard (TBI-CA)

Belt guards provide protection from rotating pulleys and belts. Belt guards meet OSHA standards.

Motor Cover (TBI-CA)

Weatherproof motor cover shields the motor and drive components from dust, dirt, and moisture for indoor/outdoor installations. Motor covers meet OSHA standards.

Inspection Section

Inspection sections are an easily removable length of duct and are recommended to improve serviceability. Inspection sections are provided with a full diameter removable access panel.

Inspection Door

Bolted or hinged inspection door provides access through the fan tube for inspection of the propeller, bearings, and drives.

Easy Access Construction (TBI-CA)

Recommended to provide inspection, cleaning, and service of internal fan components. Allows for the removal of the fan shaft and bearings through the housing without removing the fan from the duct.

Inlet and Outlet Guards

Removable inlet and outlet guards provide protection for personnel and equipment in ducted or non-ducted installations. Inlet and outlet guards meet OSHA standards.

Inlet Bell with Inlet Guard

Inlet bells minimize entry losses in non-ducted applications by providing more uniform airflow into the propeller blades. Inlet bells with inlet guard meet OSHA standards.

Companion Flanges

Companion inlet flanges and outlet flanges with prepunched holes are available for all fan sizes.

Shaft Seal (TBI-CA)

Neoprene or felt shaft seals are available to prohibit leakage of air into the bearing compartment of the fan.

Universal Mounting Brackets

Universal Mounting brackets include all hardware necessary to position the fan horizontally or vertically in either base mount or ceiling hung applications.

Extended Wiring (TDI)

Motor wiring is extended to the exterior of the fan for easy installation in the field.

Mounting Rails (TBI-CA)

Mounting rails are required for horizontal mounting of TBI-CA belt driven fans when the motor is to be located in the 3 or 9 o'clock position or for all vertical applications. Universal mounting brackets are required.

Isolators

Both base mount and hanging isolators are available in either neoprene or spring mounts. The isolators are furnished in sets of four and are sized to match the weight of each fan.

Special Coatings

Special coatings are available for protective purposes. Coatings are applied before assembly so that each manufactured component is coated inside and out. Painting the exterior a specified color for appearance is also an option. See Greenheck's Product Application Guides for a complete list of coatings available and their chemical resistance, available online at www.greenheck.com.

UL/cUL-705

UL / cUL 705 electrical listing on 50 or 60 hz motors. Motors supplied by



Disconnect Switches

Toggle and heavy duty disconnect switches are available for positive electrical shut-off and safety in servicing fans. The switches can be factory mounted or shipped loose for field mounting.

- NEMA-1 – General purpose (indoor)
- NEMA-3R – Rainproof (outdoor)
- NEMA-4 – Watertight (outdoor)
- NEMA-7 & 9 – Class 1 and 2 hazardous locations.

Greenheck will not factory mount NEMA-7 & 9 disconnect switches.

Windband w/ Butterfly Dampers

Bolt on section that eliminates rain penetration from upblast, roof mounted units. Gasket over raw edge reduces damper noise when closing.



Curb Cap

Provides transition from square roof curb to tubular fan housing. Welded to fan inlet and includes reinforcing gussets for extra strength.

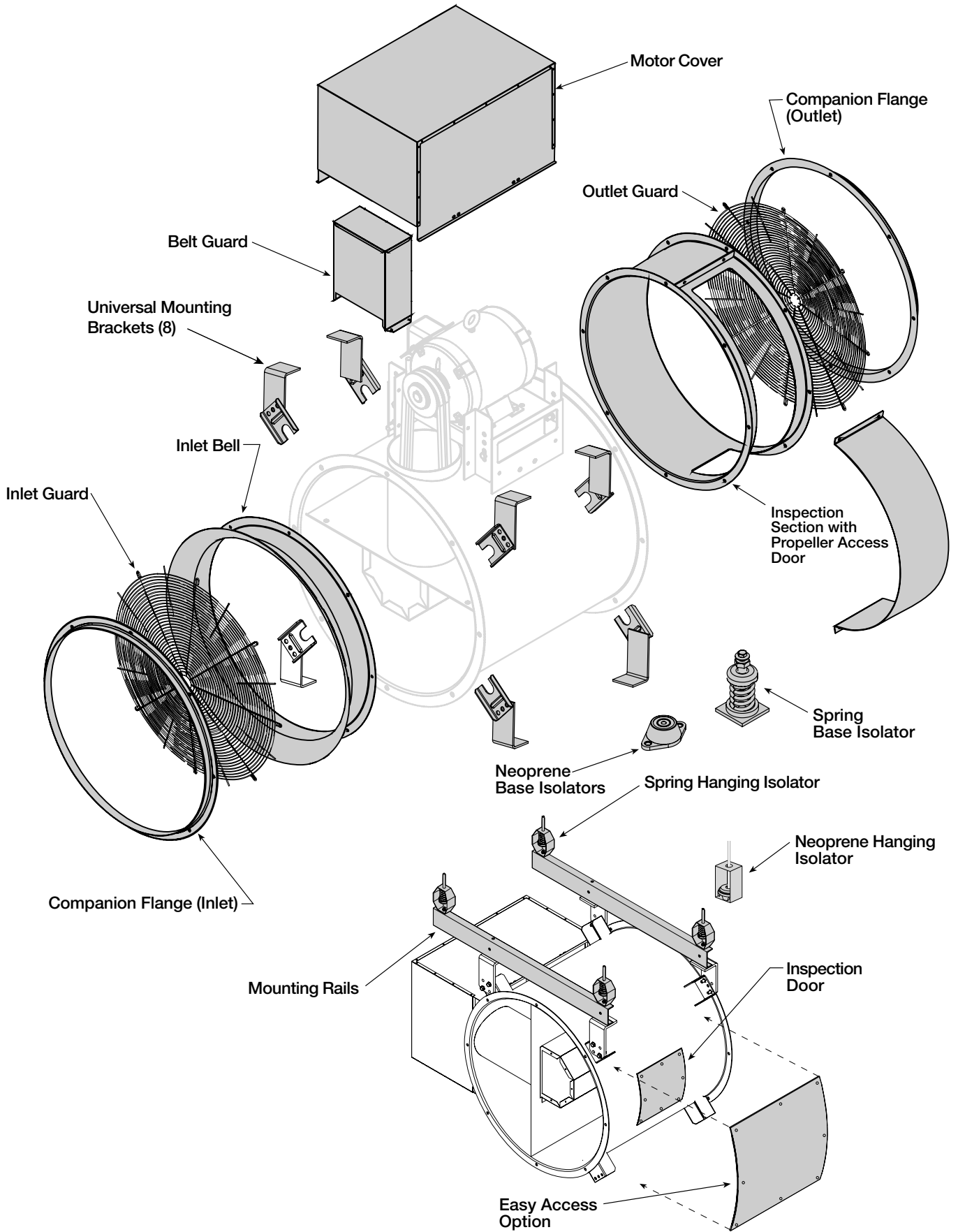

TDI Size 18

Direct Drive Level 4



Shown with optional mounting brackets

Air Flow →

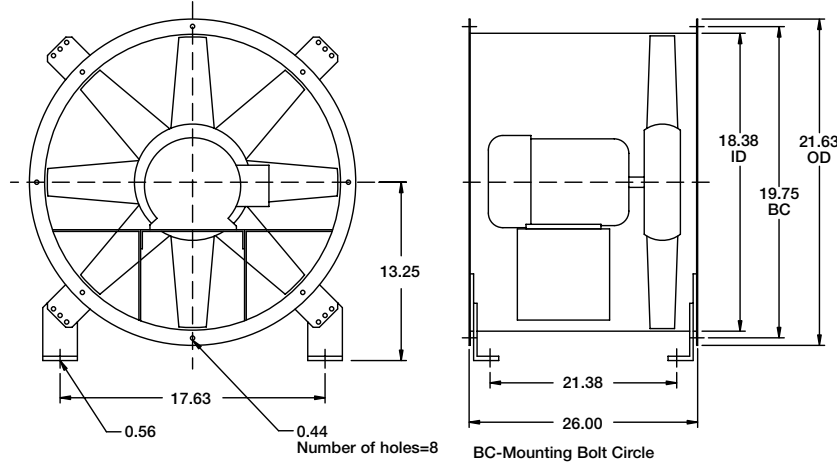

Specifications

- Max Fan RPM = 1770
- Max Motor Frame size = 182T
- Min Motor Frame size = 182T
- Fan Tube Gauge = 10 ga.
- Approx. Weight (LM) = 135 lbs.
- Number of Blades = 8

Outlet Velocity (FPM) = CFM / 1.84 ft²
 Tip Speed = Fan RPM x 4.71

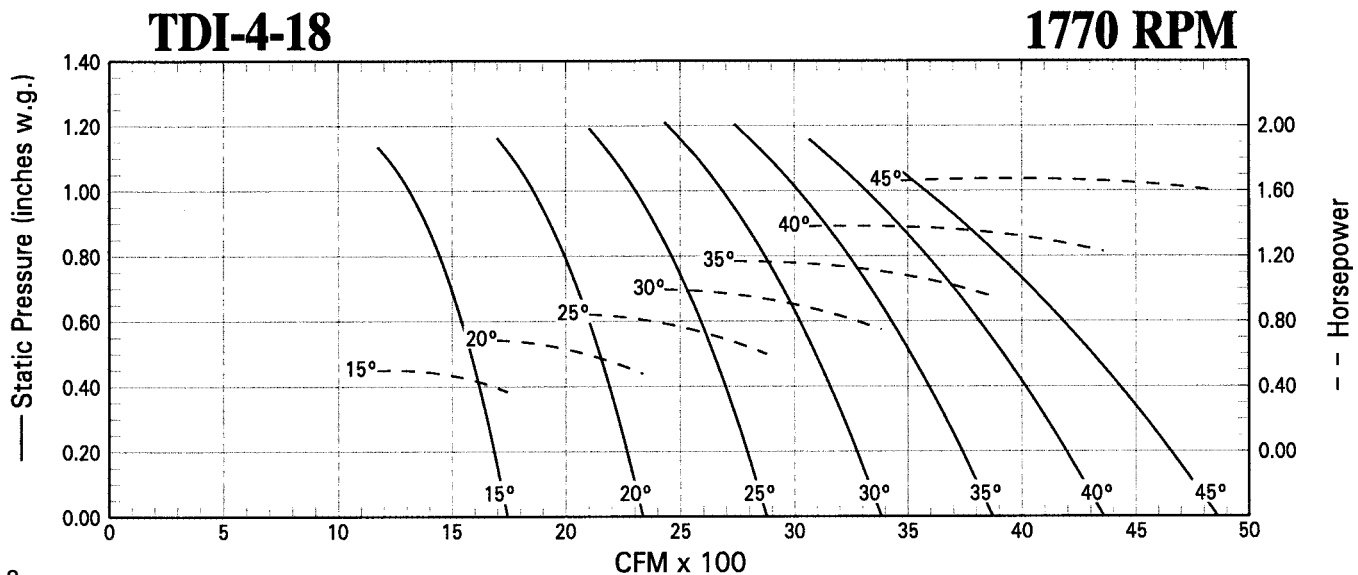
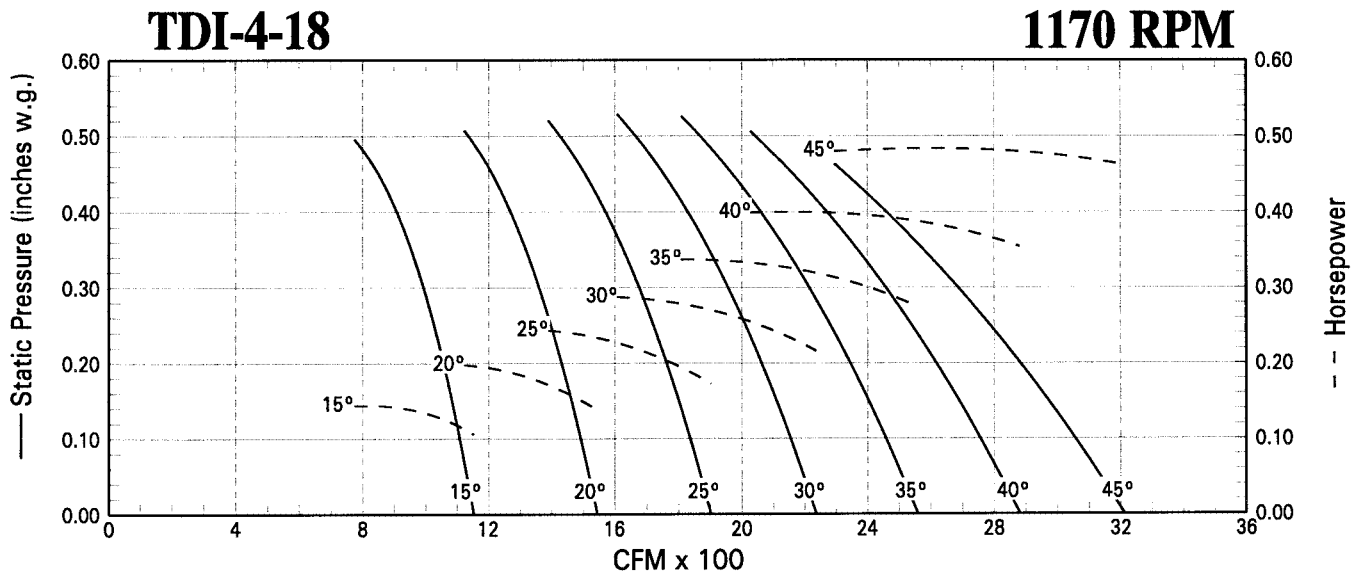

Shown with optional mounting brackets

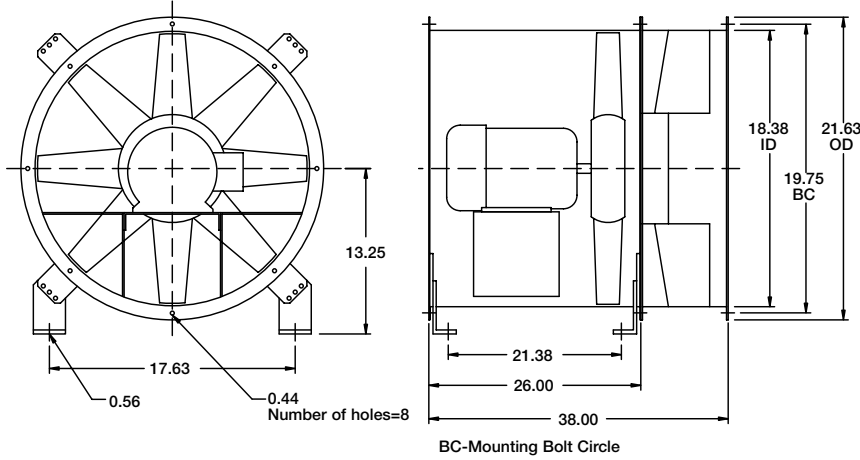

Specifications

- Max Fan RPM = 1770
- Max Motor Frame size = 182T
- Min Motor Frame size = 182T
- Fan Tube Gauge = 10 ga.
- Approx. Weight (LM) = 175 lbs.
- Number of Blades = 8

Outlet Velocity (FPM) = CFM / 1.84 ft²
Tip Speed = Fan RPM x 4.71

TDI-5-18

1170 RPM

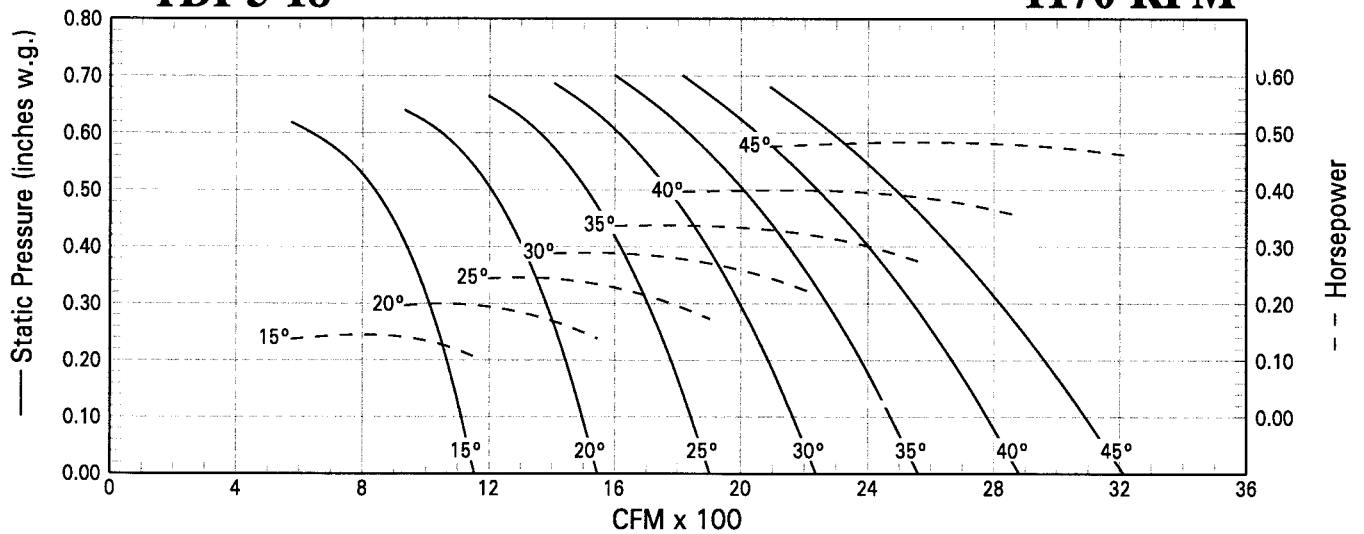

TDI-5-18

1770 RPM

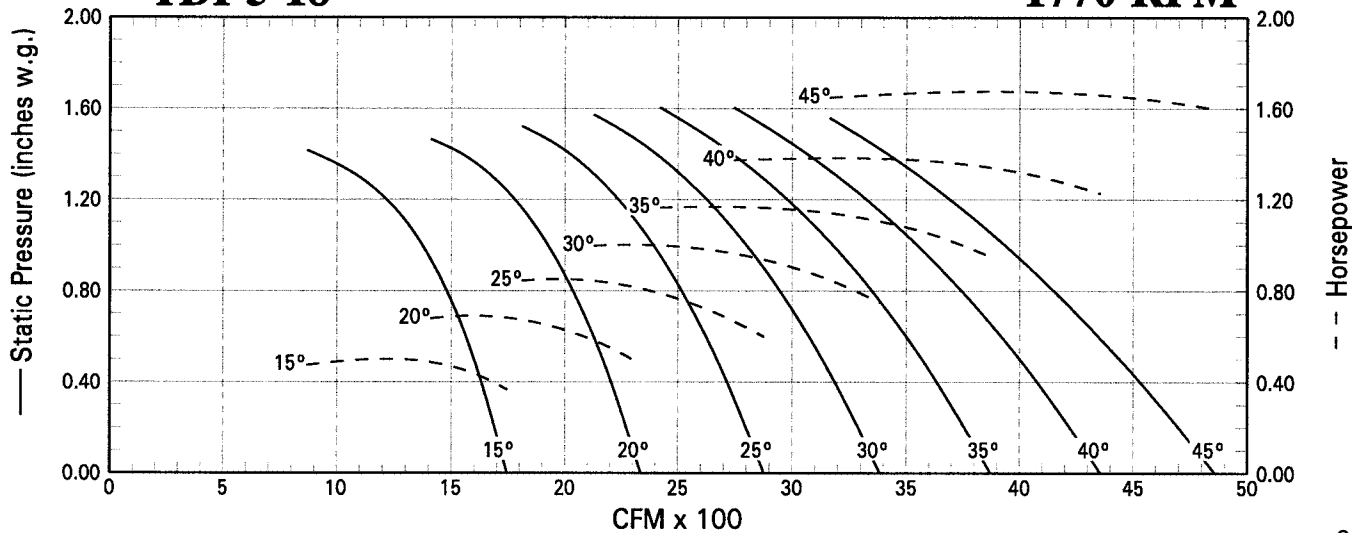

TDI Size 20

Direct Drive Level 4

Shown with optional mounting brackets

Air Flow →

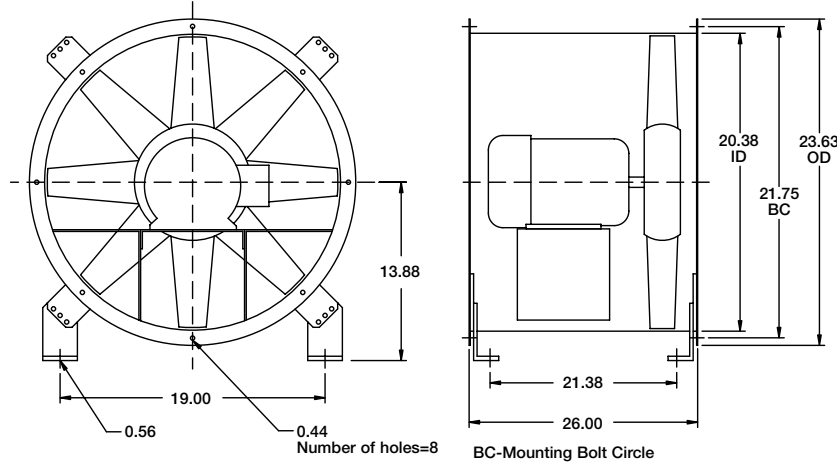

Specifications

- Max Fan RPM = 1770
- Max Motor Frame size = 184T
- Min Motor Frame size = 182T
- Fan Tube Gauge = 10 ga.
- Approx. Weight (LM) = 145 lbs.
- Number of Blades = 8

Outlet Velocity (FPM) = $CFM / 2.26 \text{ ft}^2$
 Tip Speed = Fan RPM x 5.24

TDI-4-20

1170 RPM

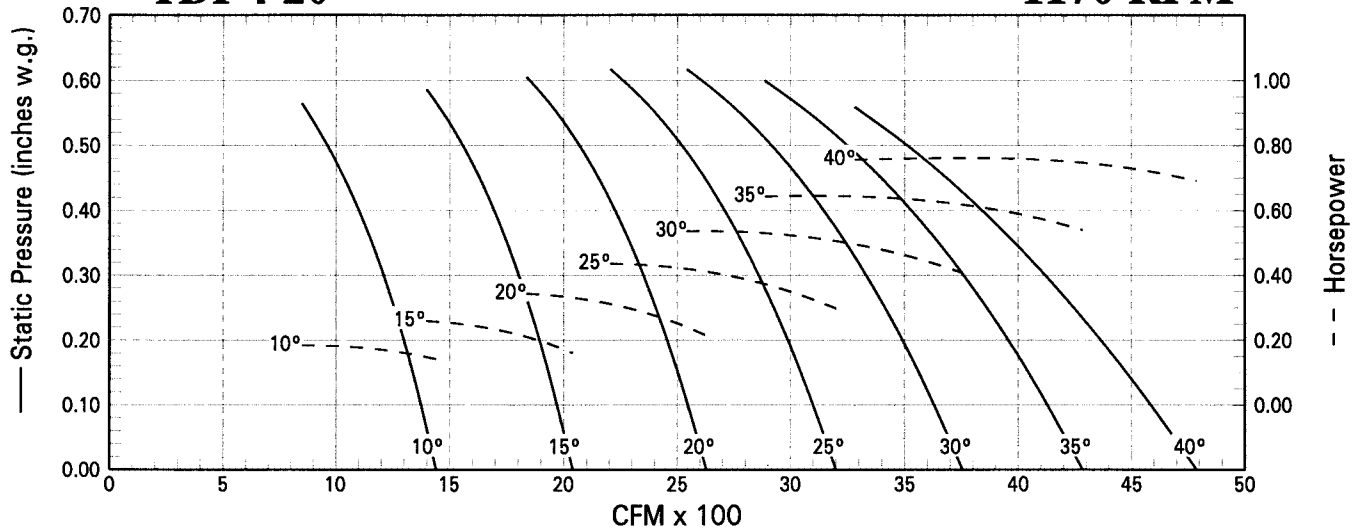

TDI-4-20

1770 RPM

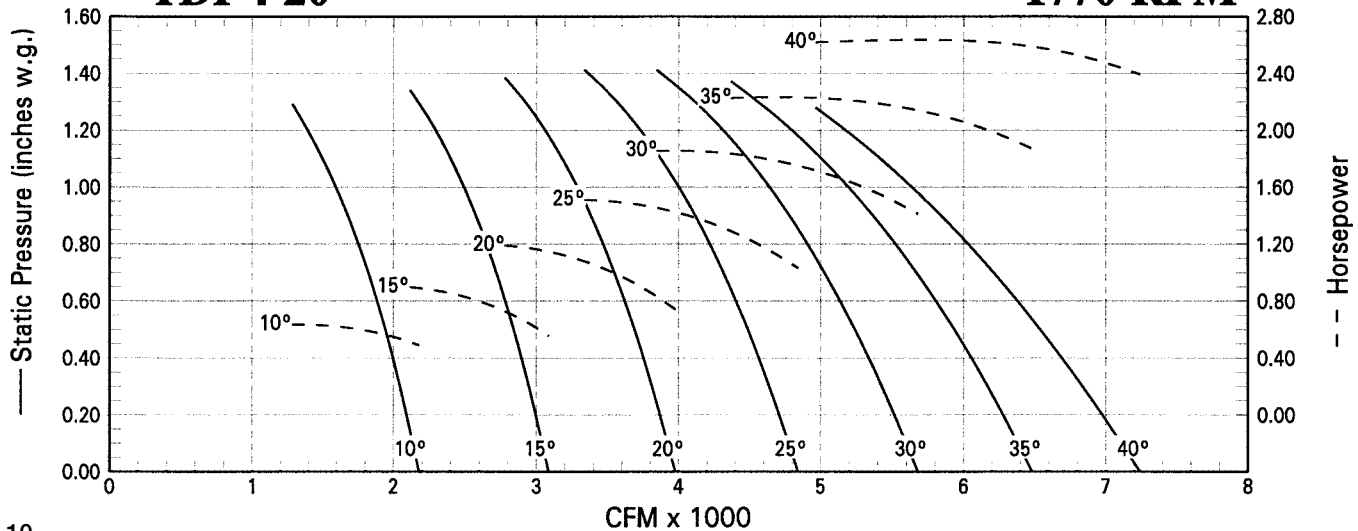

Shown with optional mounting brackets

Air Flow →

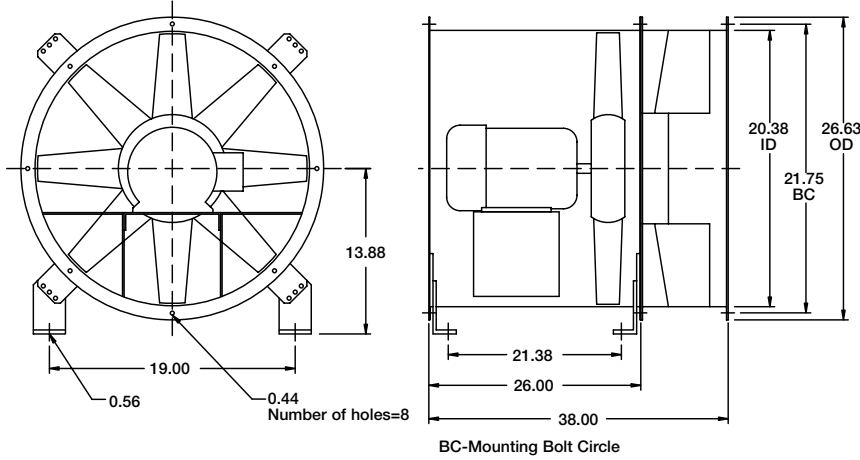

Specifications

- Max Fan RPM = 1770
- Max Motor Frame size = 184T
- Min Motor Frame size = 182T
- Fan Tube Gauge = 10 ga.
- Approx. Weight (LM) = 190 lbs.
- Number of Blades = 8

Outlet Velocity (FPM) = CFM / 2.26 ft²
Tip Speed = Fan RPM x 5.24

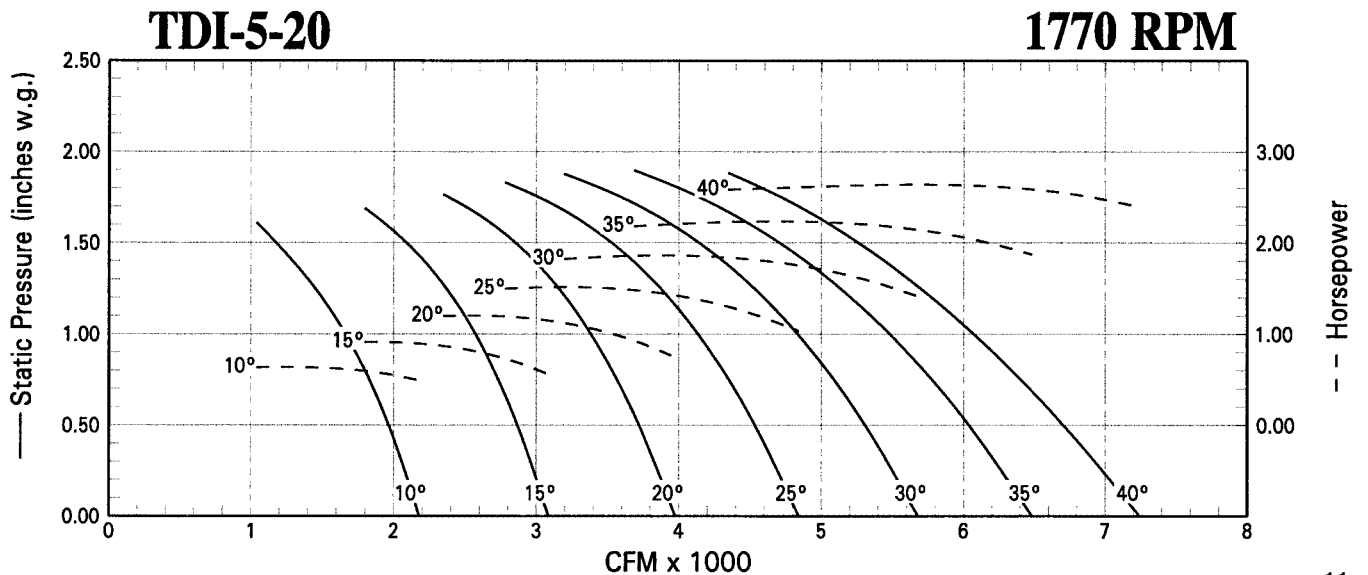
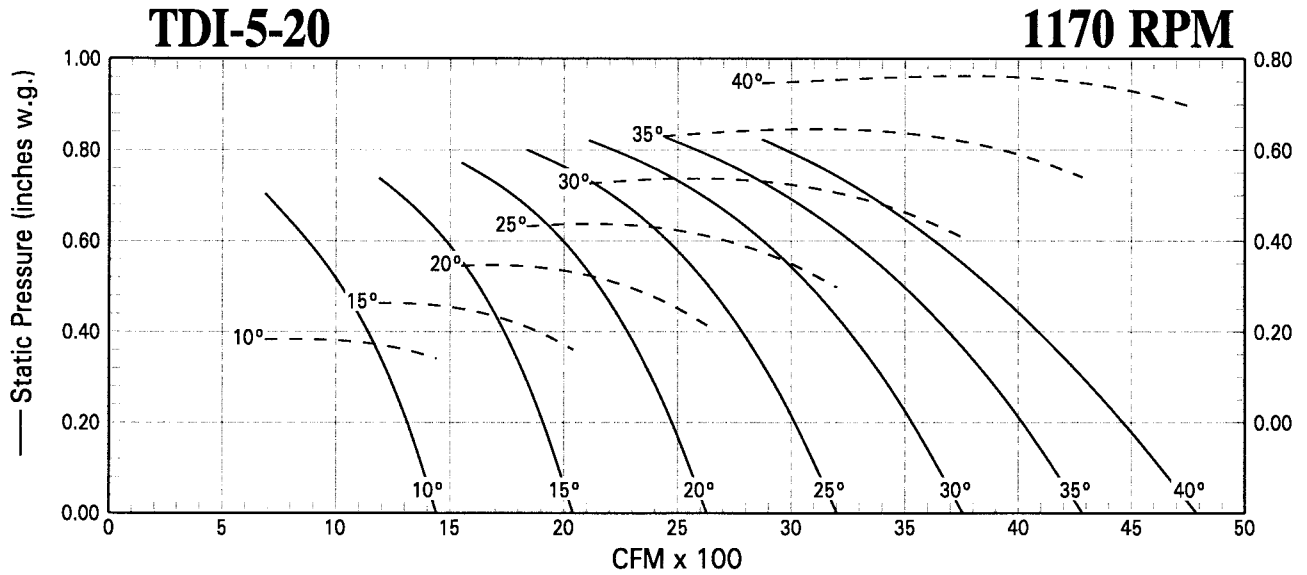

TDI Size 24

Direct Drive Level 4



Shown with optional mounting brackets

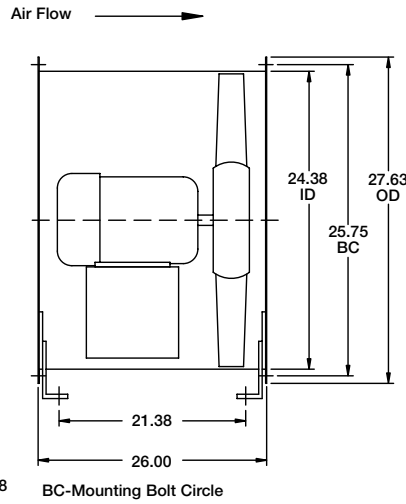
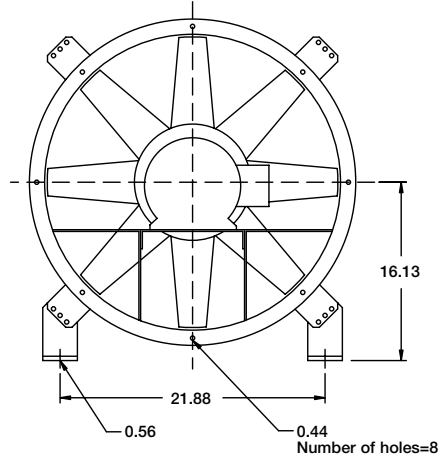

Specifications

- Max Fan RPM = 1770
- Max Motor Frame size = 215T
- Min Motor Frame size = 182T
- Fan Tube Gauge = 10 ga.
- Approx. Weight (LM) = 165 lbs.
- Number of Blades = 8

Outlet Velocity (FPM) = $CFM / 3.21 \text{ ft}^2$
 Tip Speed = Fan RPM x 6.28

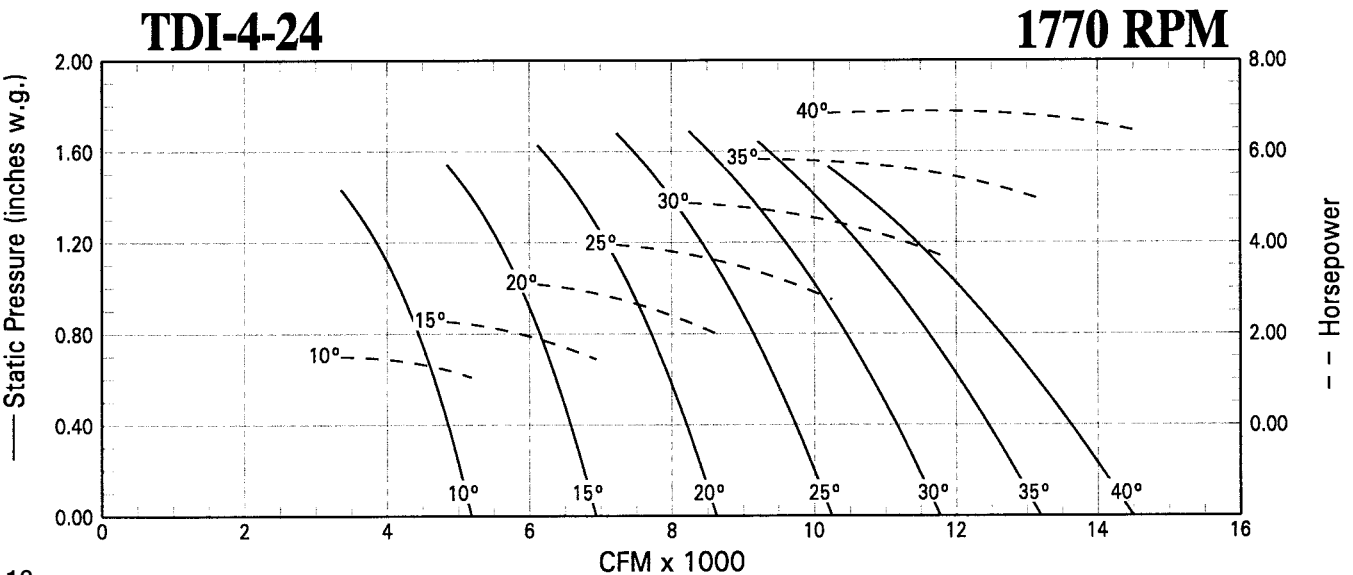
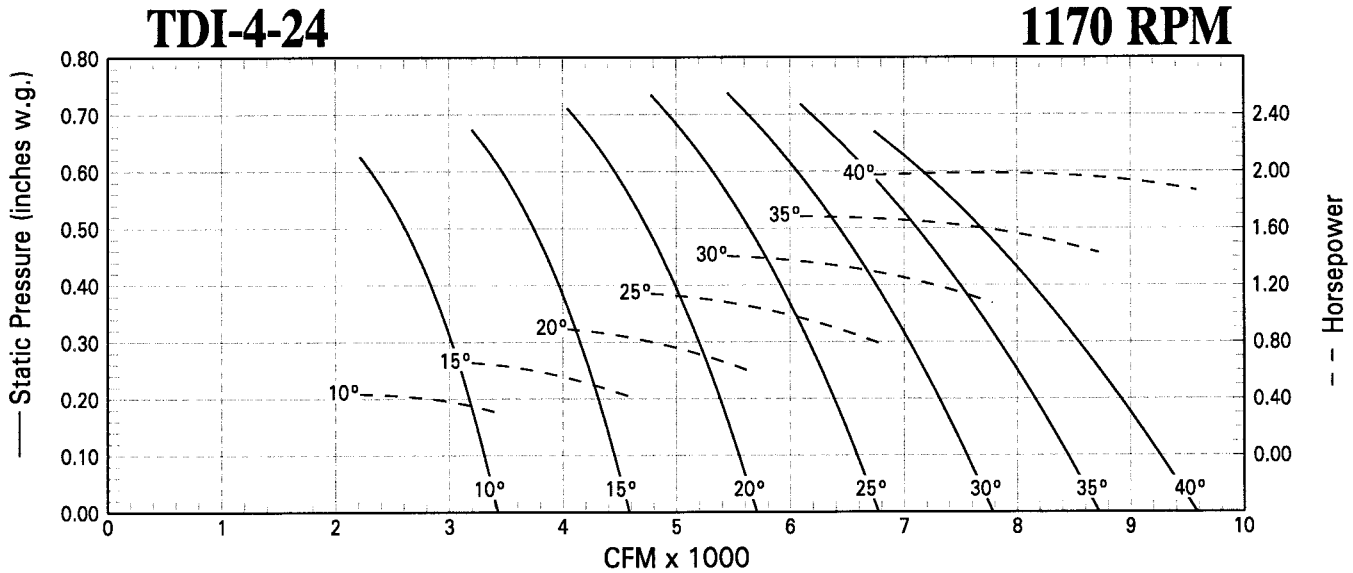

Shown with optional mounting brackets

Air Flow →

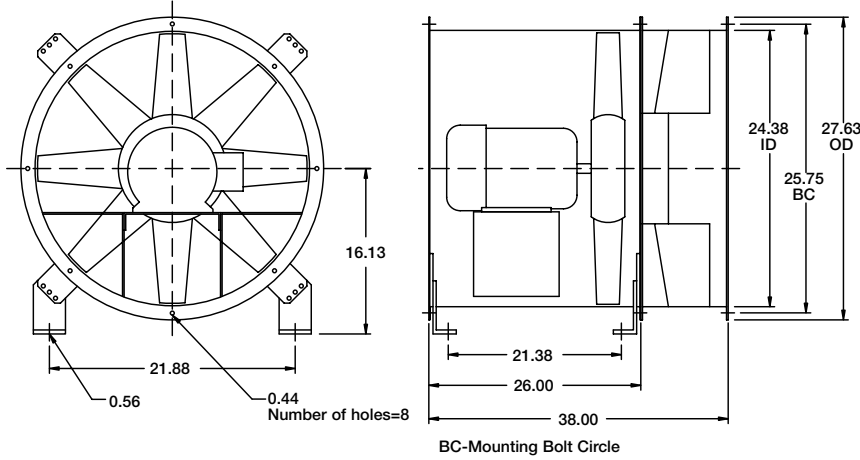

Specifications

- Max Fan RPM = 1770
- Max Motor Frame size = 215T
- Min Motor Frame size = 182T
- Fan Tube Gauge = 10 ga.
- Approx. Weight (LM) = 220 lbs.
- Number of Blades = 8

Outlet Velocity (FPM) = CFM / 3.21 ft²
Tip Speed = Fan RPM x 6.28

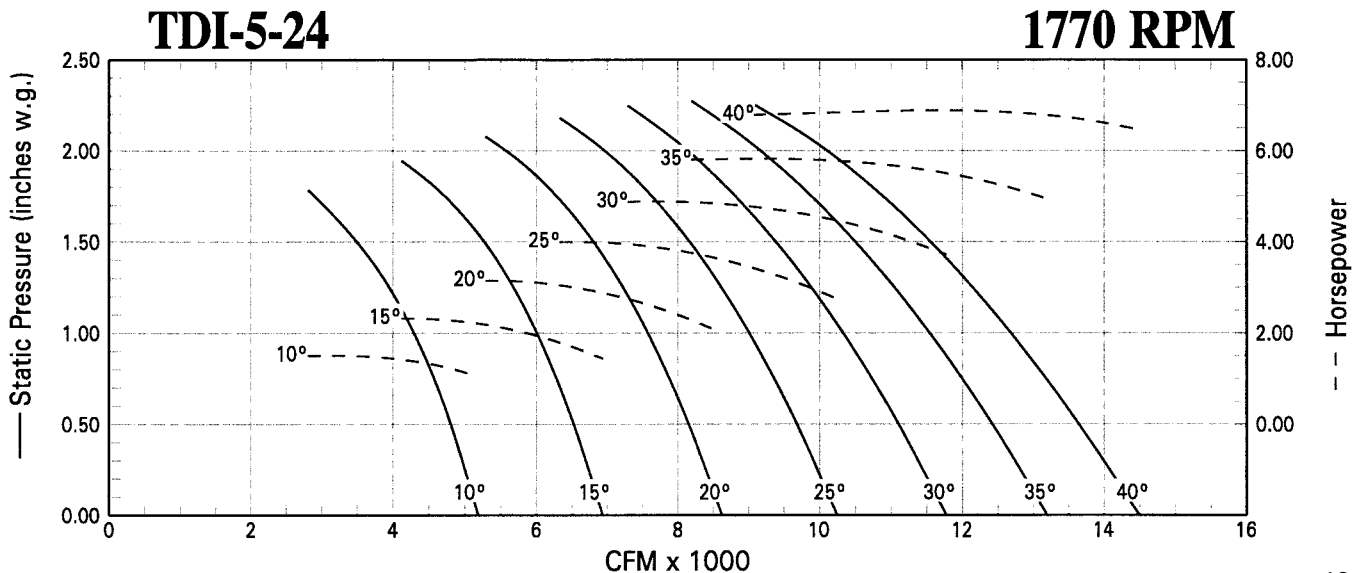
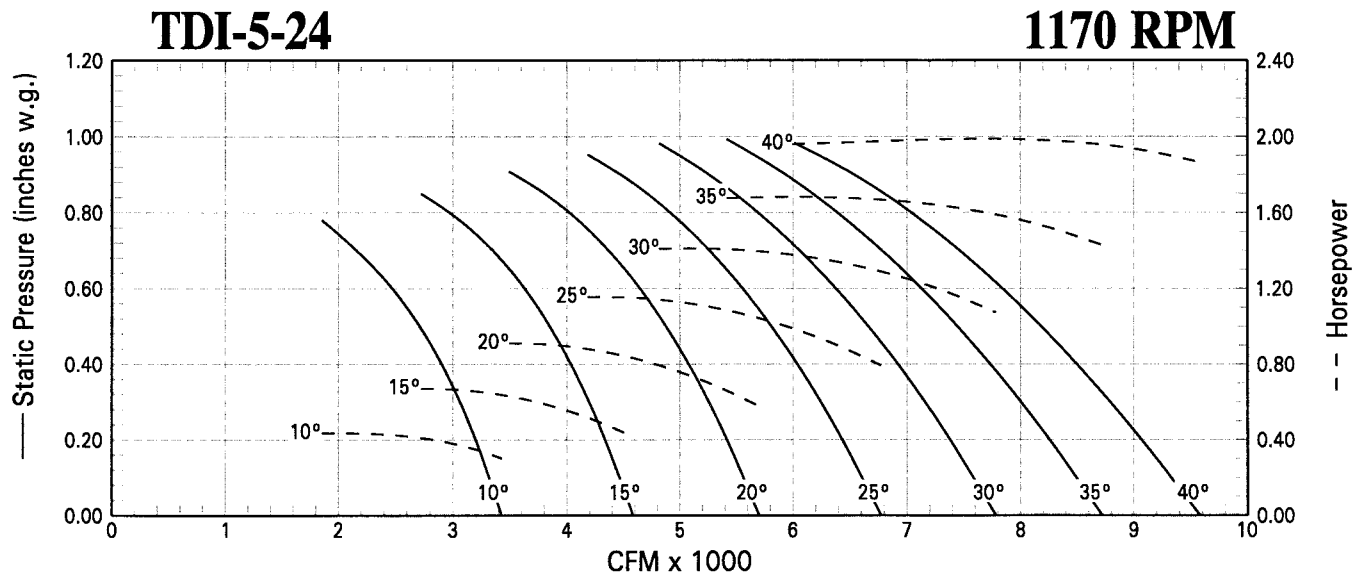

TDI Size 30

Direct Drive Level 4



Shown with optional mounting brackets

Air Flow →

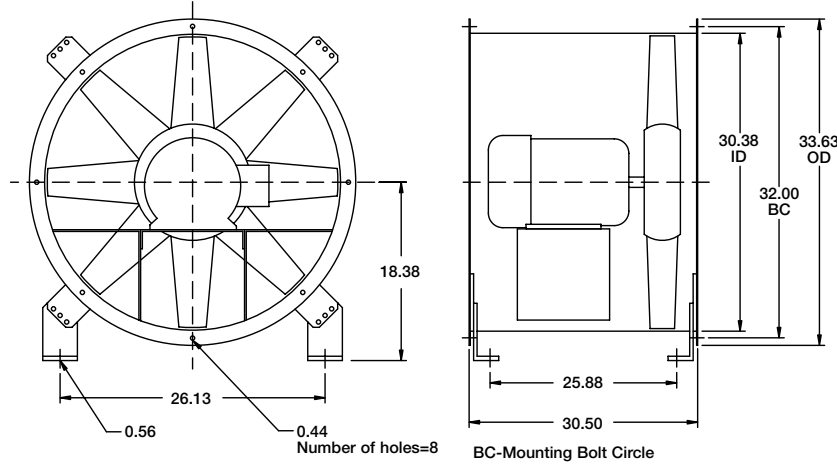

Specifications

- Max Fan RPM = 1770
- Max Motor Frame size = 254T
- Min Motor Frame size = 182T
- Fan Tube Gauge = 10 ga.
- Approx. Weight (LM) = 230 lbs.
- Number of Blades = 8

Outlet Velocity (FPM) = $CFM / 5.07 \text{ ft}^2$
 Tip Speed = Fan RPM x 7.85

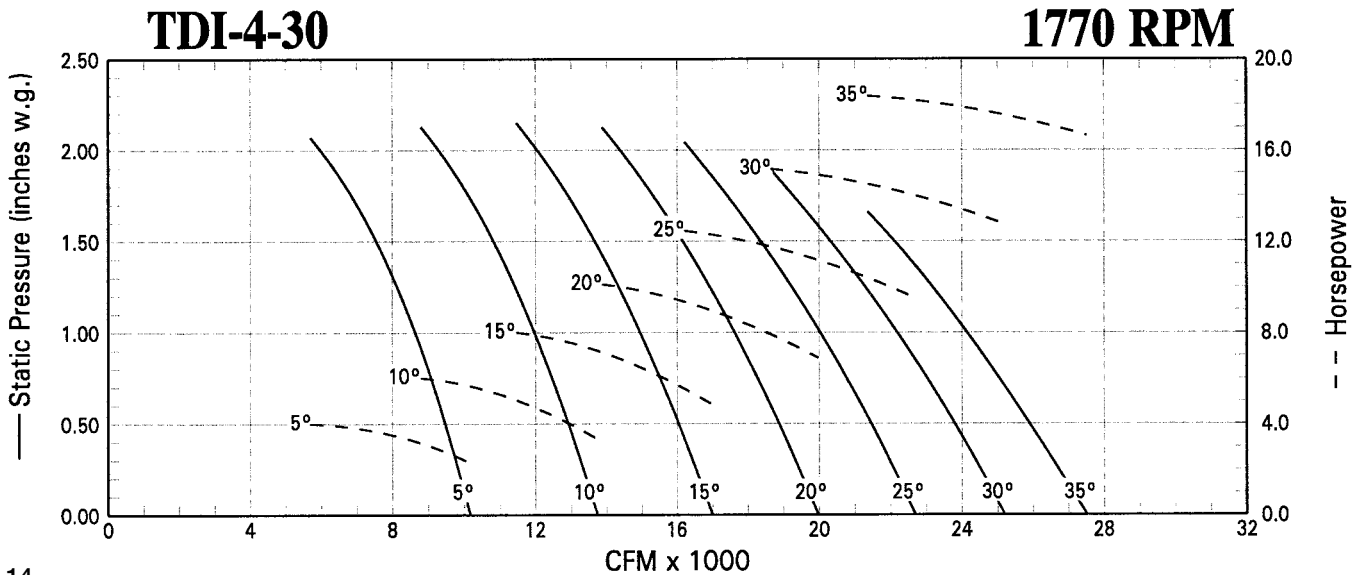
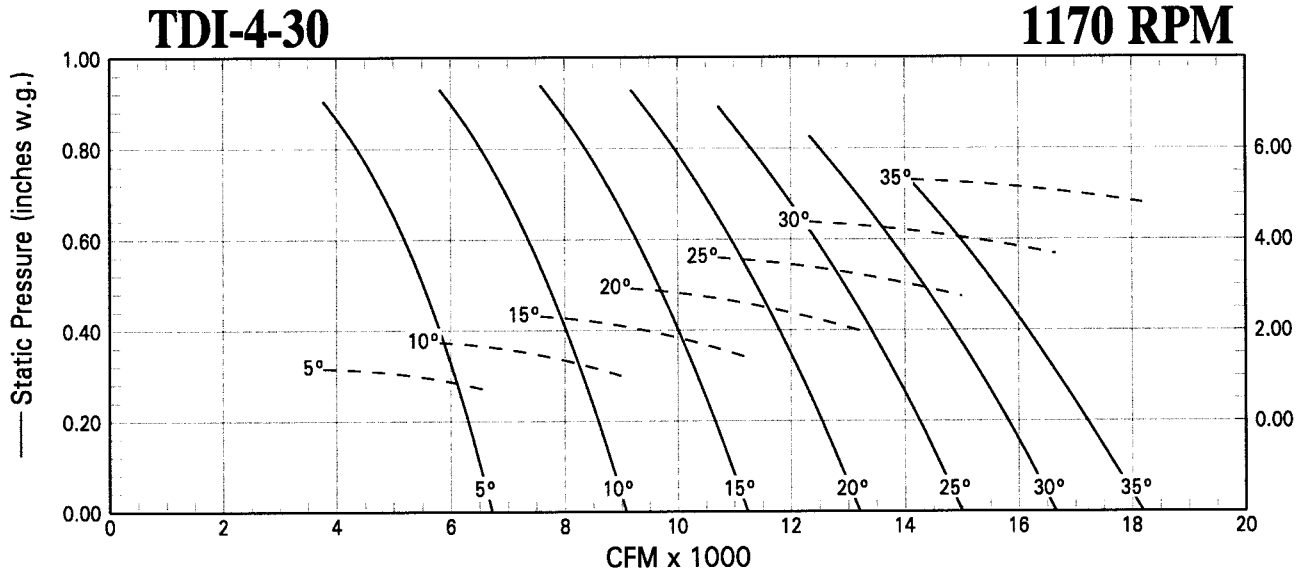

Shown with optional mounting brackets

Air Flow →

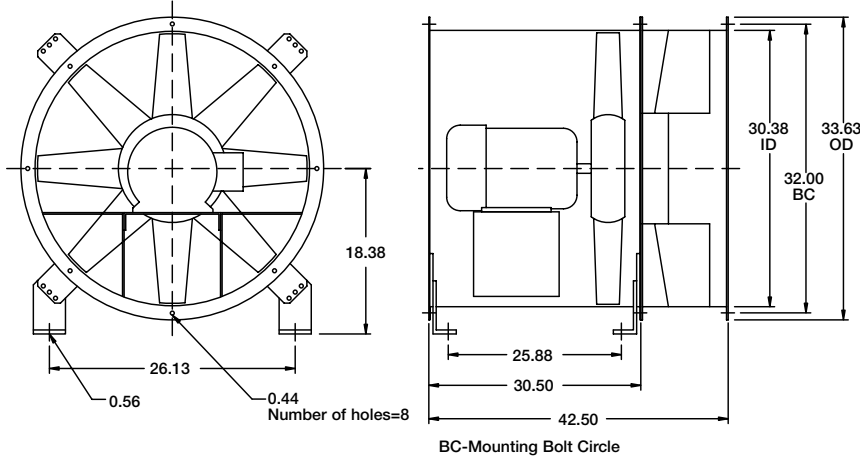

Specifications

- Max Fan RPM = 1770
- Max Motor Frame size = 254T
- Min Motor Frame size = 182T
- Fan Tube Gauge = 10 ga.
- Approx. Weight (LM) = 300 lbs.
- Number of Blades = 8

Outlet Velocity (FPM) = CFM / 5.07 ft²
Tip Speed = Fan RPM x 7.85

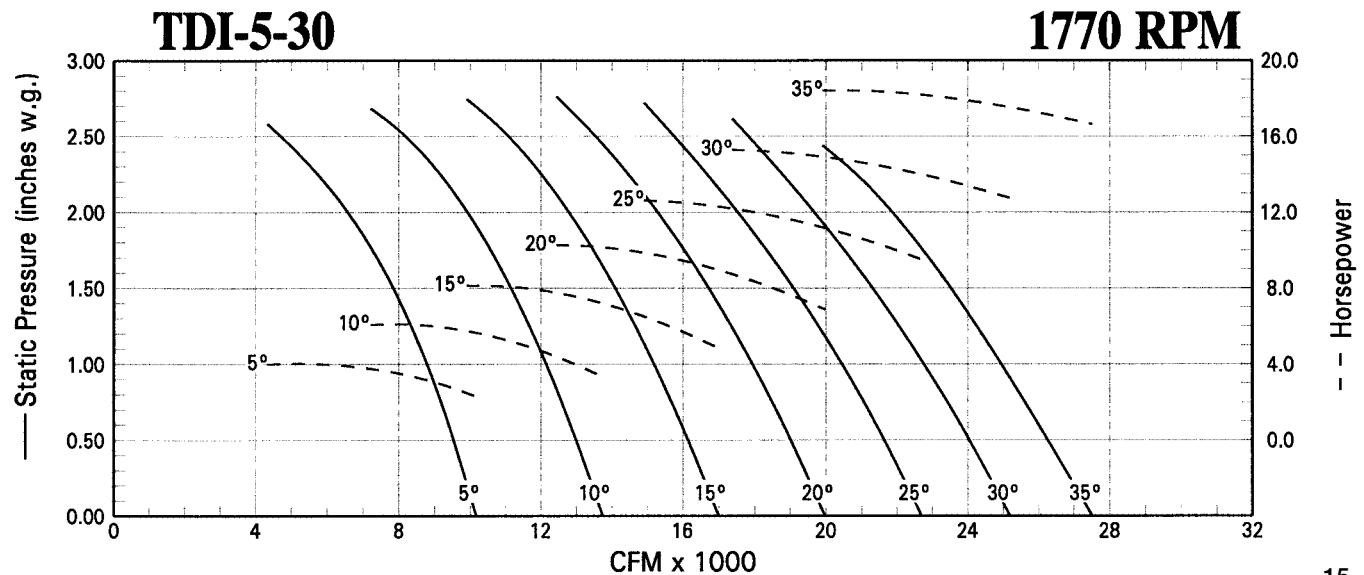
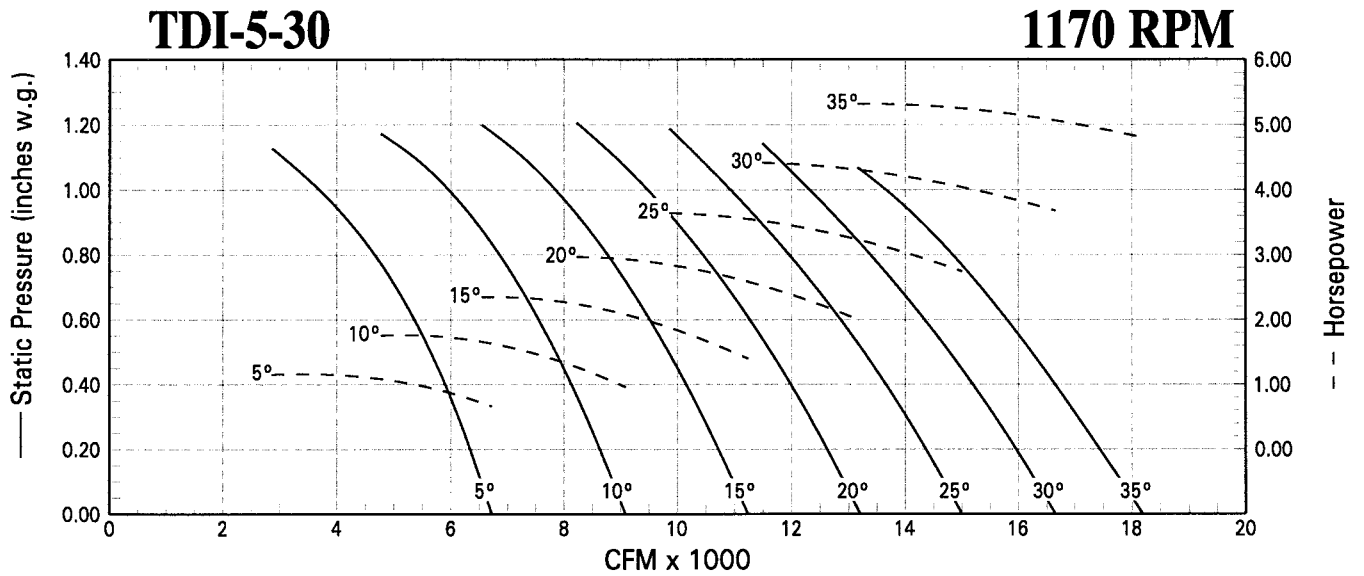

TDI Size 36

Direct Drive Level 4



Shown with optional mounting brackets

Air Flow →

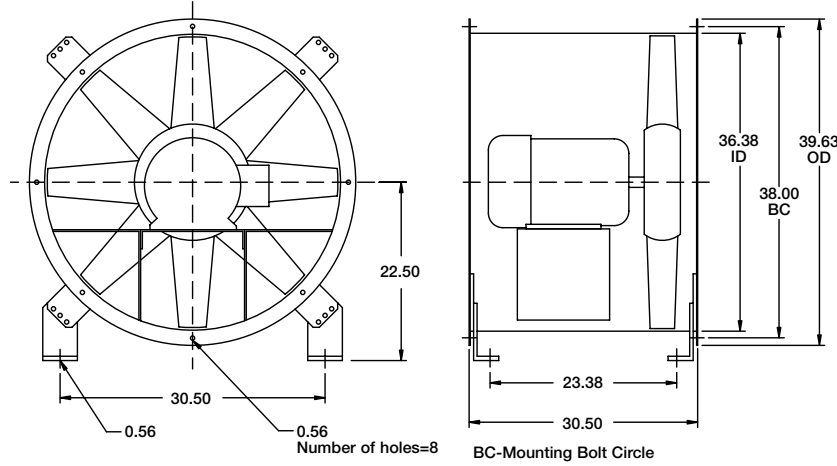

Specifications

- Max Fan RPM = 1770
- Max Motor Frame size = 256T
- Min Motor Frame size = 182T
- Fan Tube Gauge = 10 ga.
- Approx. Weight (LM) = 300 lbs.
- Number of Blades = 8

Outlet Velocity (FPM) = $CFM / 7.22 \text{ ft}^2$
 Tip Speed = Fan RPM x 9.42

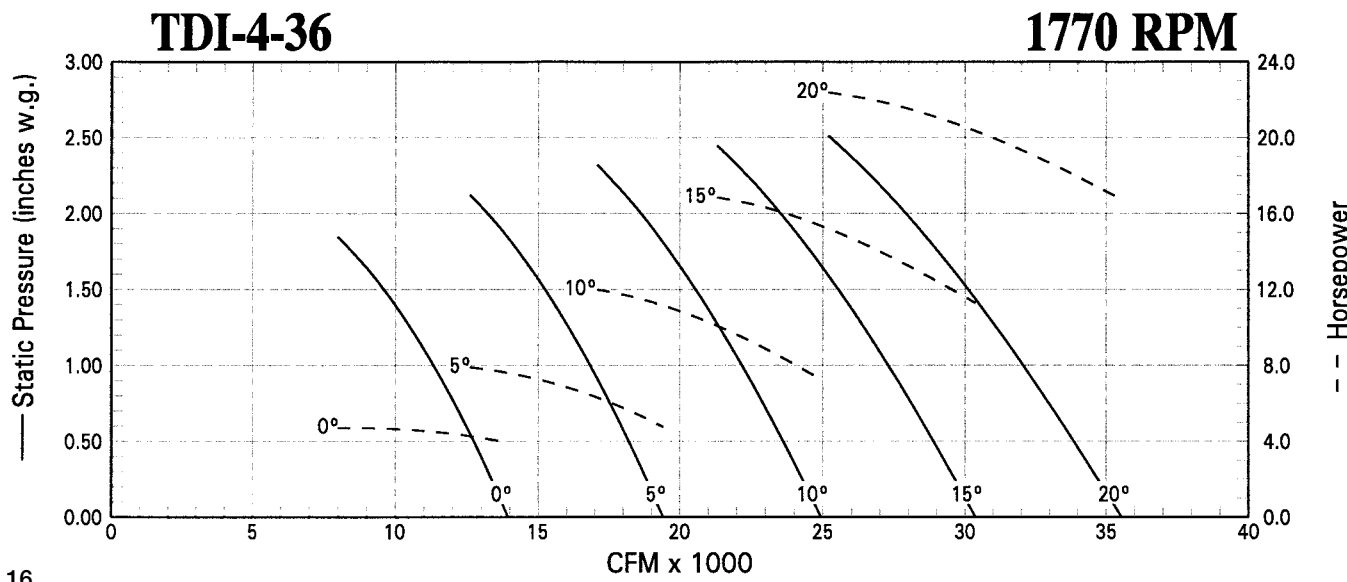
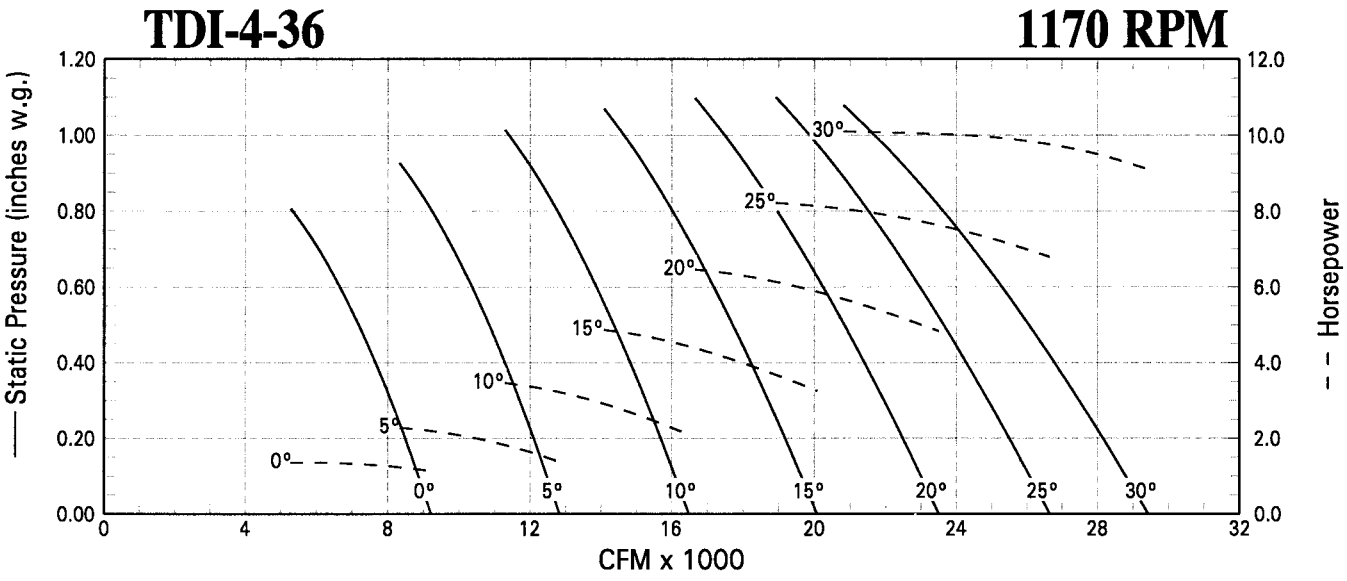

Shown with optional mounting brackets

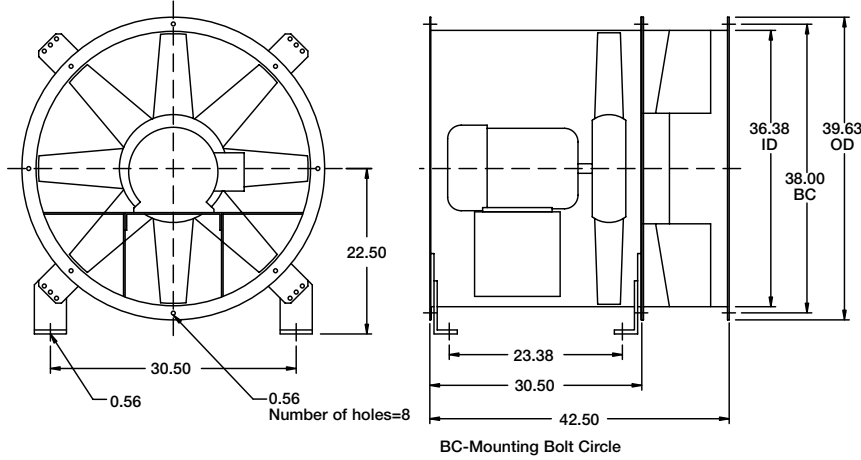

Specifications

- Max Fan RPM = 1770
- Max Motor Frame size = 256T
- Min Motor Frame size = 182T
- Fan Tube Gauge = 10 ga.
- Approx. Weight (LM) = 385 lbs.
- Number of Blades = 8

Outlet Velocity (FPM) = CFM / 7.22 ft²
Tip Speed = Fan RPM x 9.42

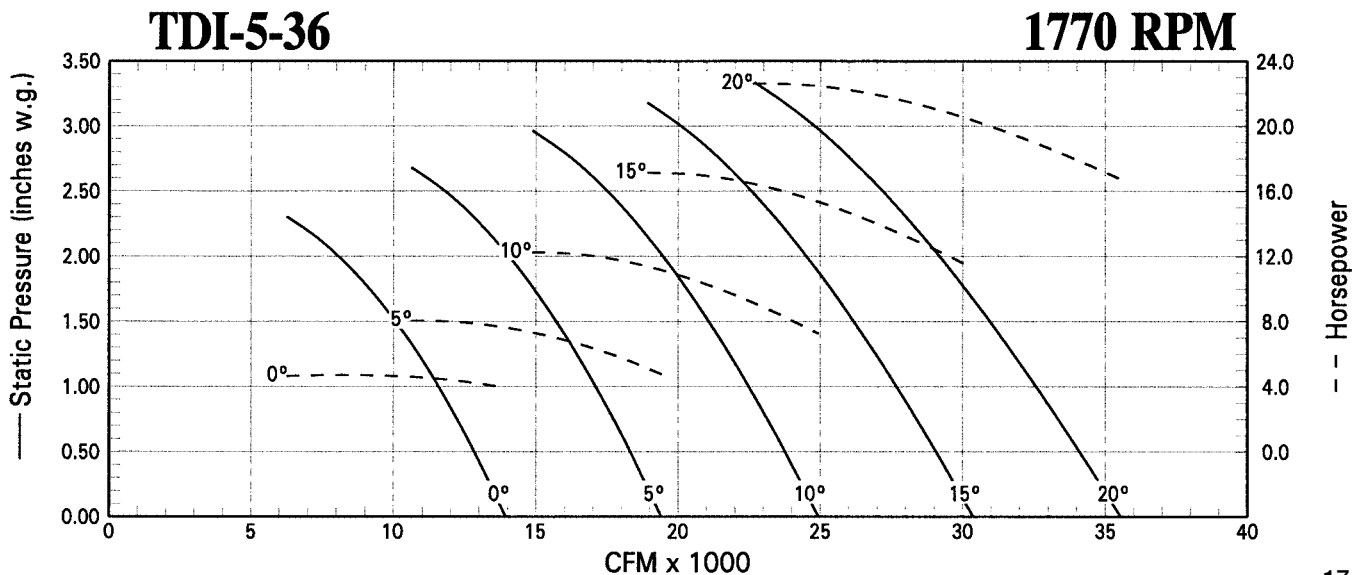
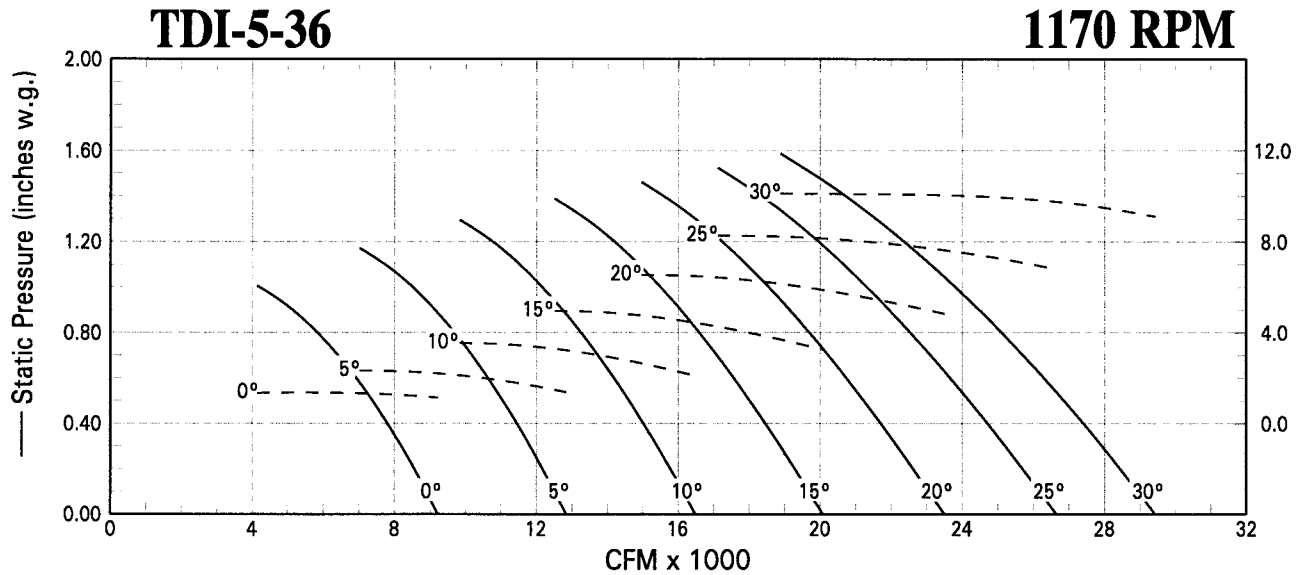

TDI Size 42

Direct Drive Level 4



Shown with optional mounting brackets

Air Flow →

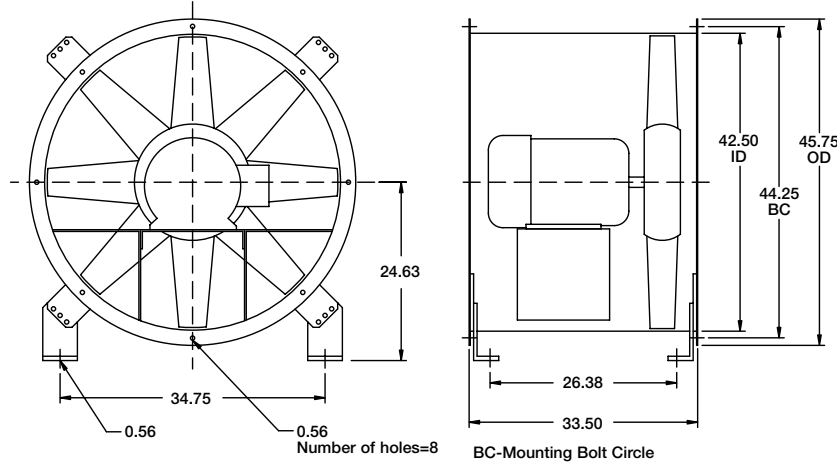

Specifications

- Max Fan RPM = 1170
- Max Motor Frame size = 286T
- Min Motor Frame size = 213T
- Fan Tube Gauge = 3/16 in.
- Approx. Weight (LM) = 445 lbs.
- Number of Blades = 10

Outlet Velocity (FPM) = $CFM / 9.85 \text{ ft}^2$
 Tip Speed = Fan RPM x 11.00

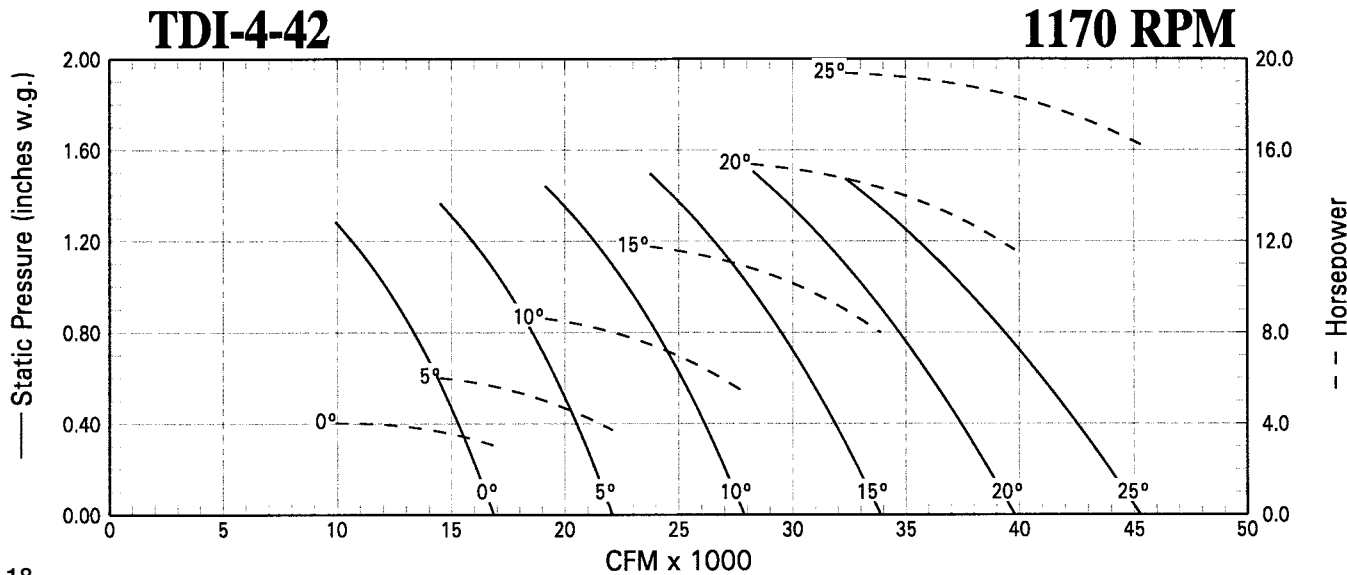
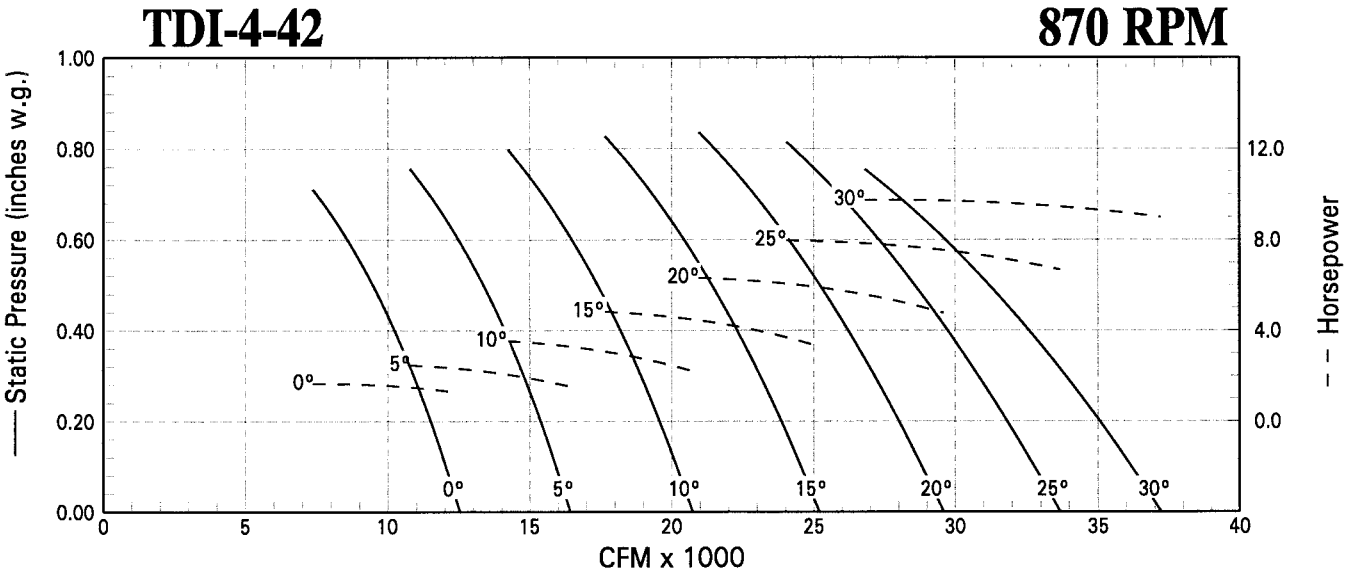

Shown with optional mounting brackets

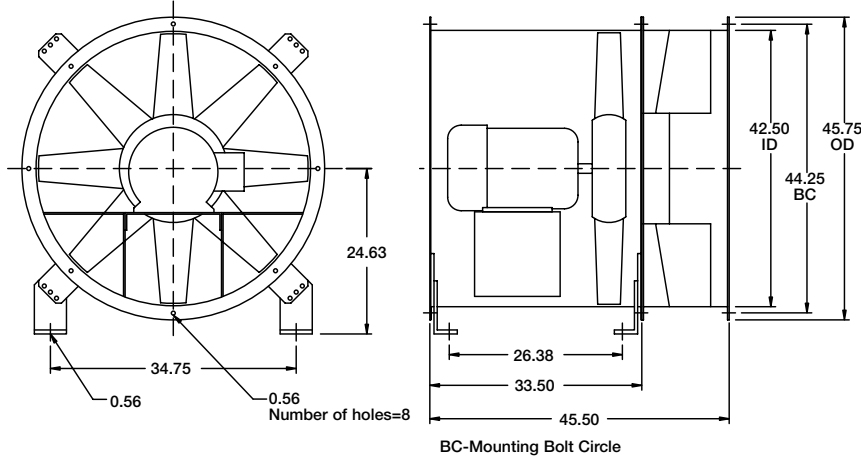

Specifications

- Max Fan RPM = 1170
- Max Motor Frame size = 286T
- Min Motor Frame size = 213T
- Fan Tube Gauge = 3/16 in.
- Approx. Weight (LM) = 570 lbs.
- Number of Blades = 10

Outlet Velocity (FPM) = CFM / 9.85 ft²
Tip Speed = Fan RPM x 11.00

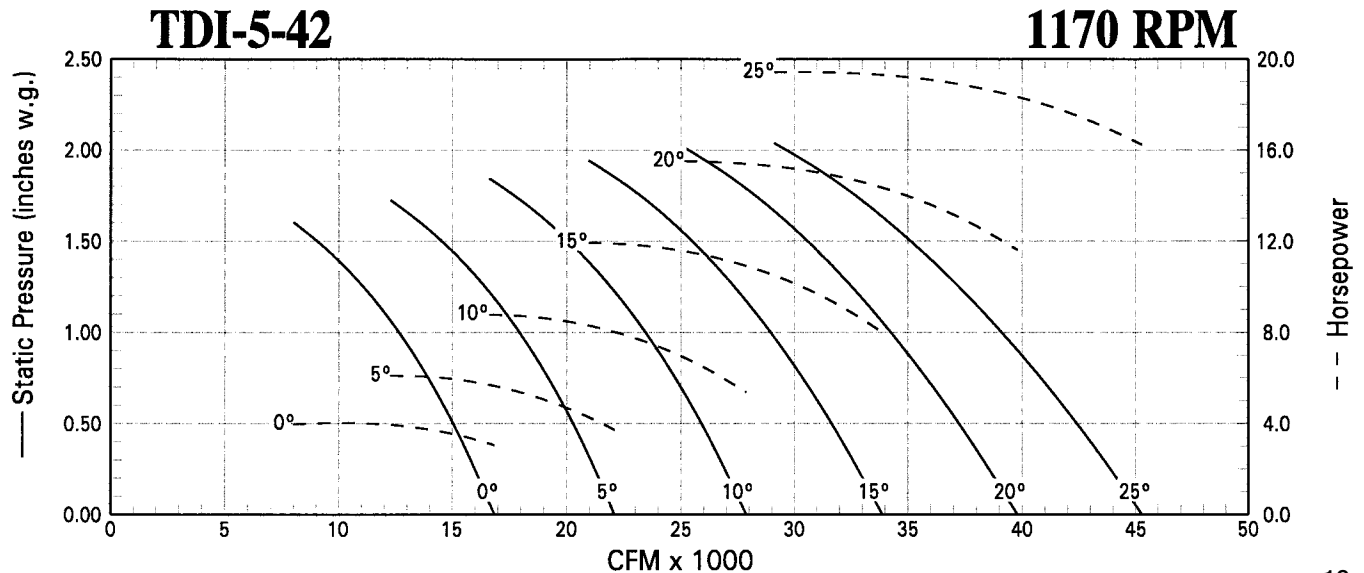
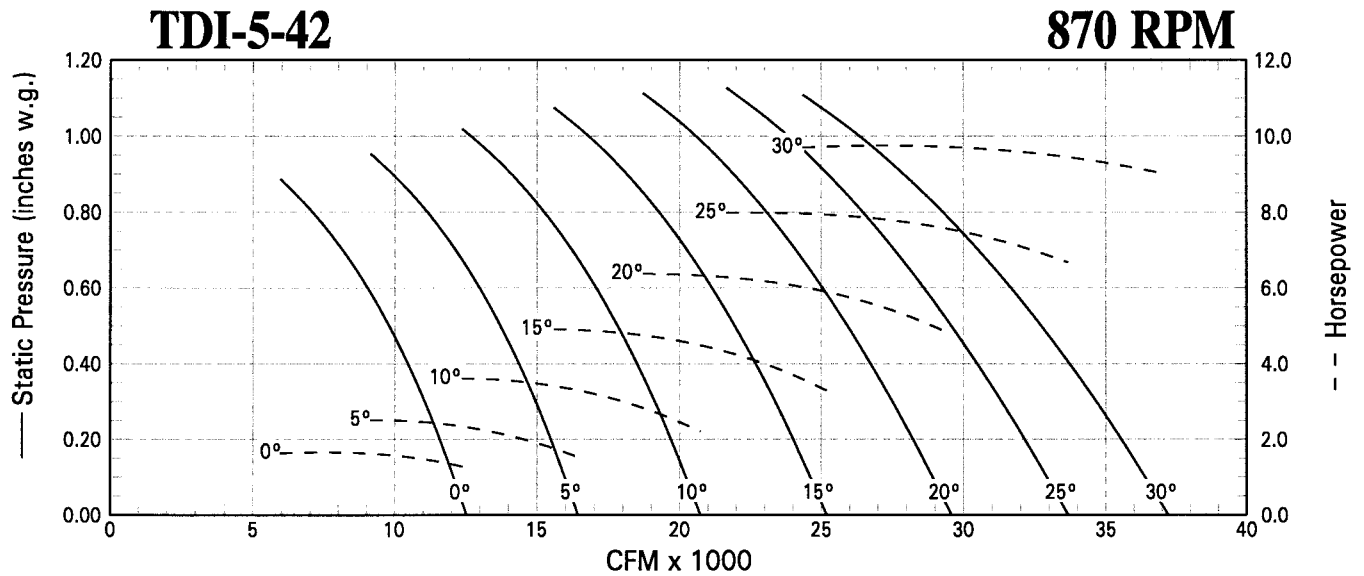

TDI Size 48

Direct Drive Level 4



Shown with optional mounting brackets

Air Flow →

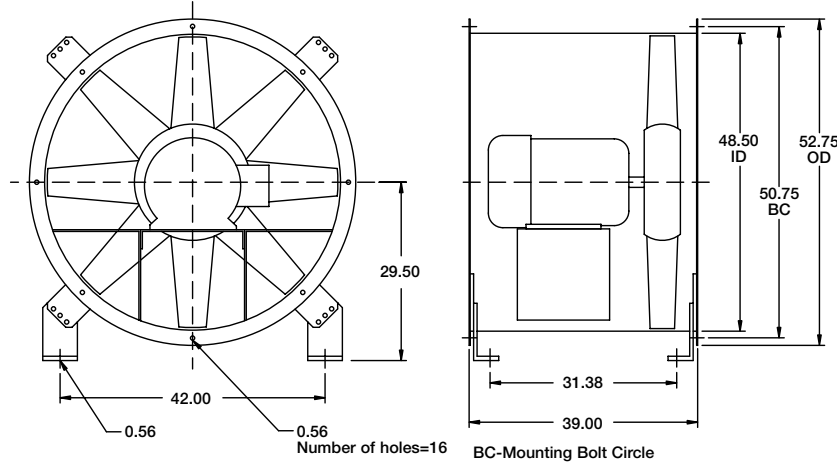

Specifications

- Max Fan RPM = 1170
- Max Motor Frame size = 364T
- Min Motor Frame size = 254T
- Fan Tube Gauge = 3/16 in.
- Approx. Weight (LM) = 670 lbs.
- Number of Blades = 12

Outlet Velocity (FPM) = $CFM / 12.83 \text{ ft}^2$
 Tip Speed = Fan RPM x 12.57

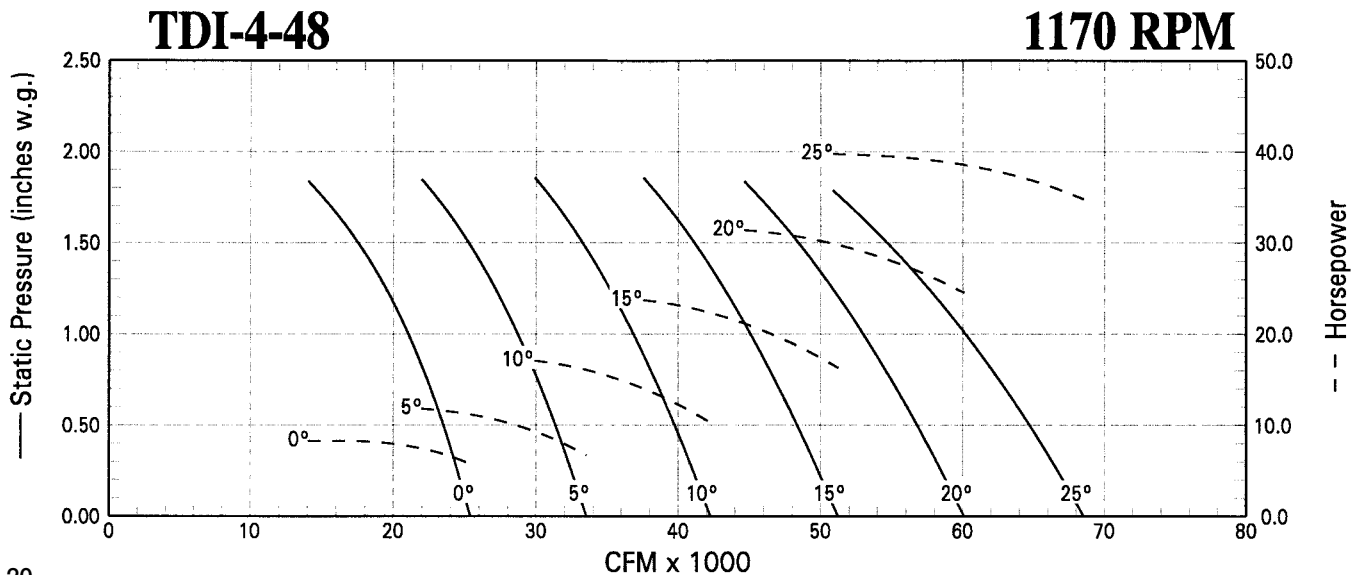
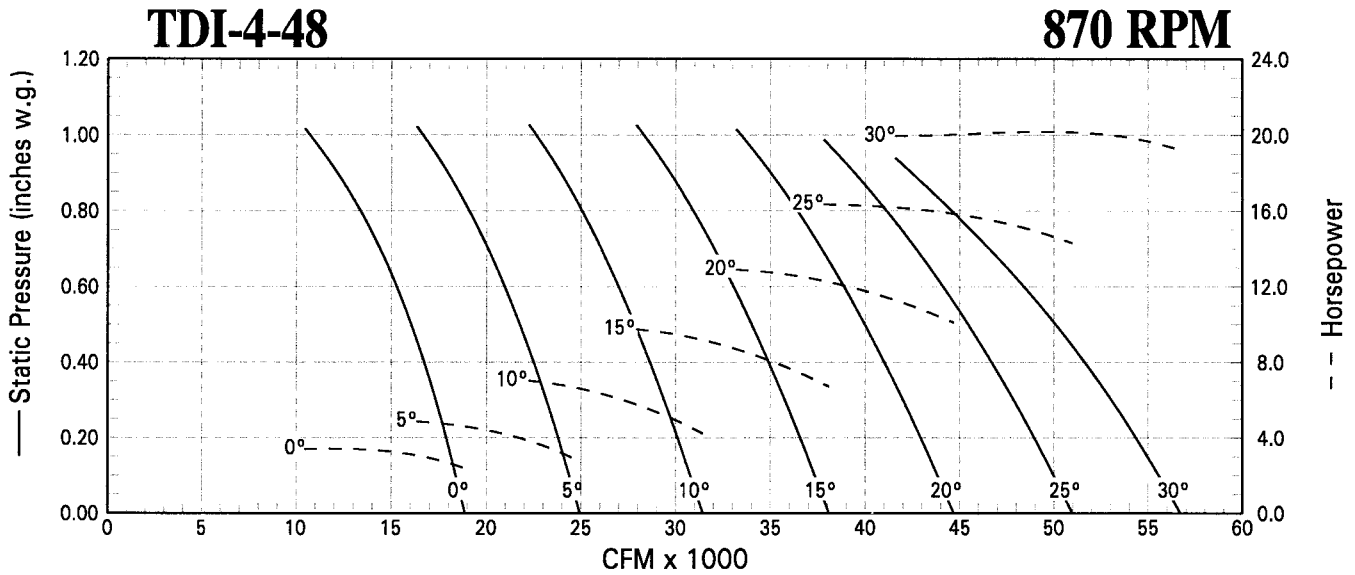

Shown with optional mounting brackets

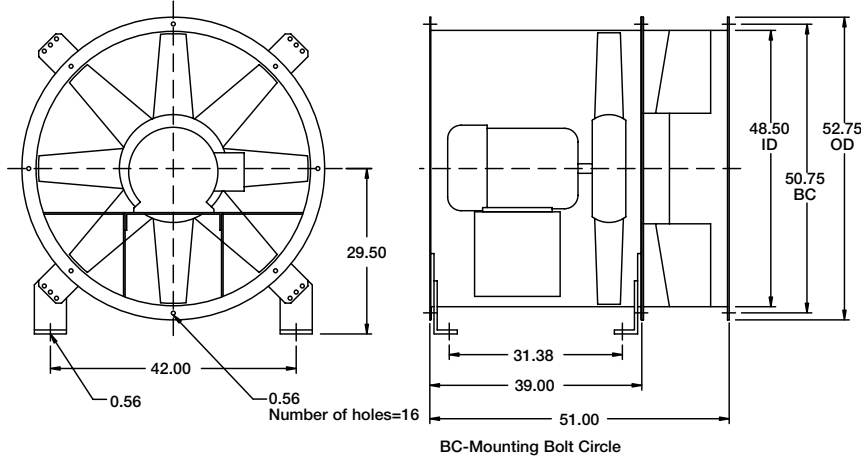

Specifications

- Max Fan RPM = 1170
- Max Motor Frame size = 364T
- Min Motor Frame size = 254T
- Fan Tube Gauge = 3/16 in.
- Approx. Weight (LM) = 850 lbs.
- Number of Blades = 12

Outlet Velocity (FPM) = CFM / 12.83 ft²
Tip Speed = Fan RPM x 12.57

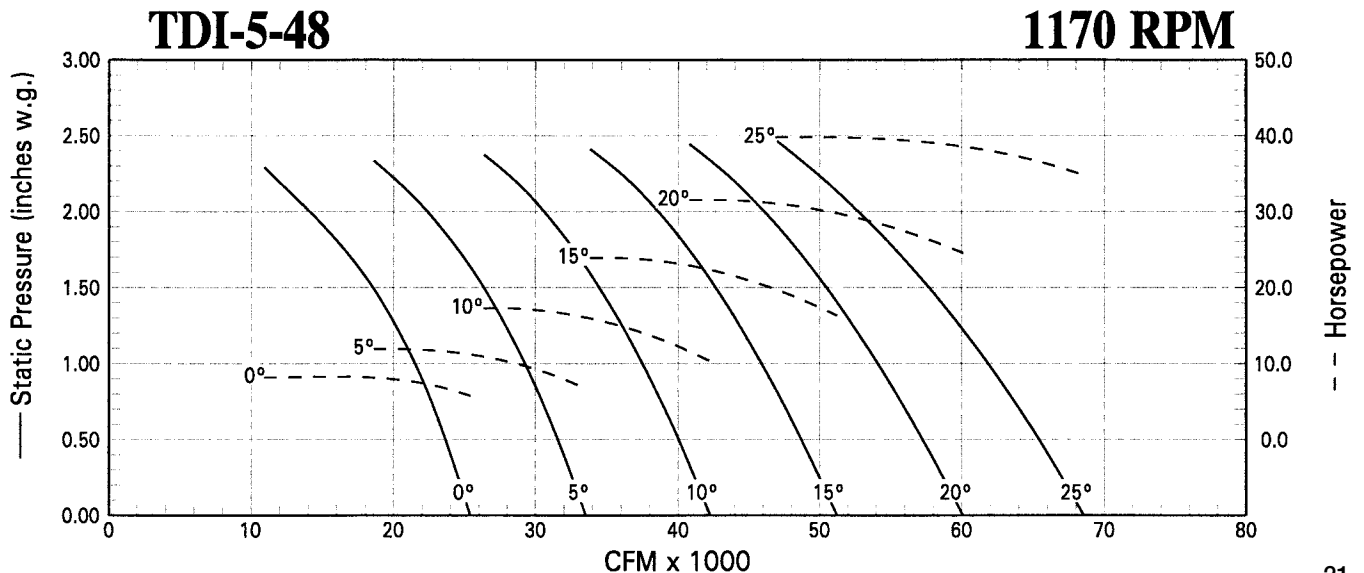
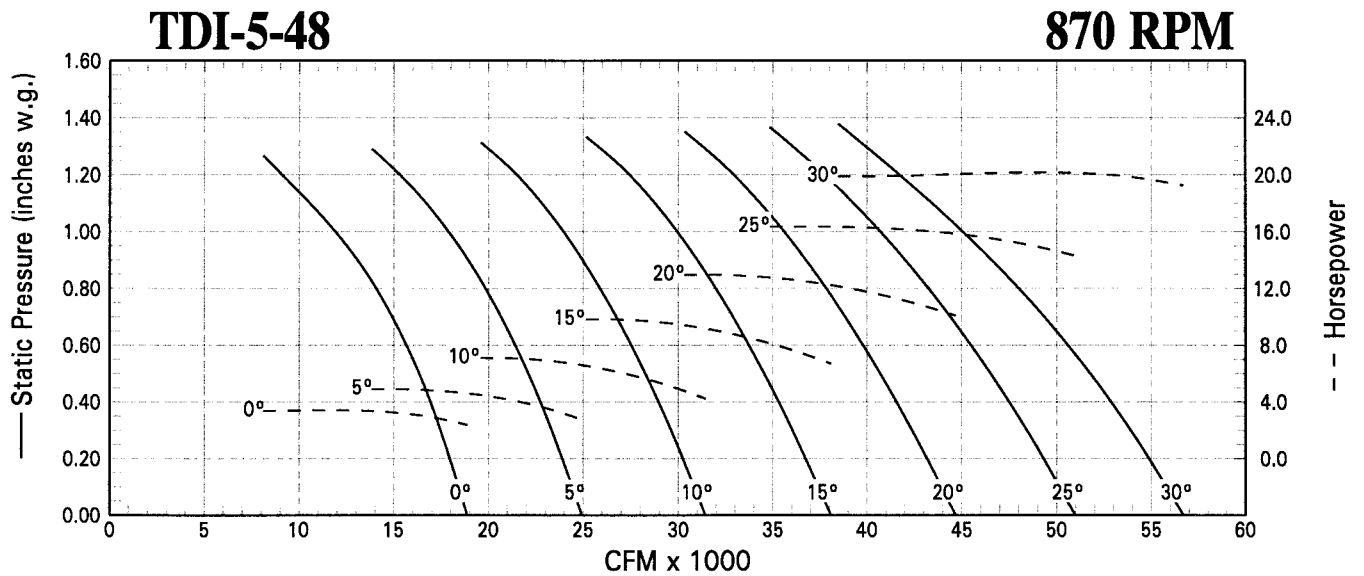

TDI Size 54

Direct Drive Level 4



Shown with optional mounting brackets

Air Flow →

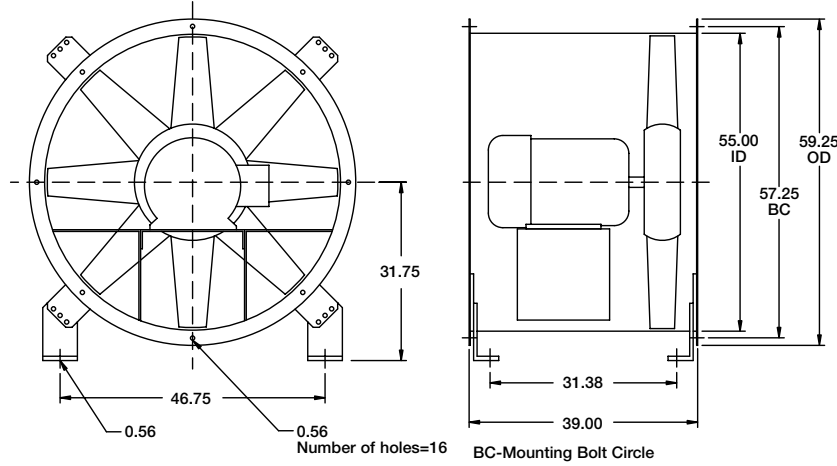

Specifications

- Max Fan RPM = 1170
- Max Motor Frame size = 365T
- Min Motor Frame size = 254T
- Fan Tube Gauge = 3/16 in.
- Approx. Weight (LM) = 745 lbs.
- Number of Blades = 12

Outlet Velocity (FPM) = CFM / 16.50 ft²
 Tip Speed = Fan RPM x 14.14

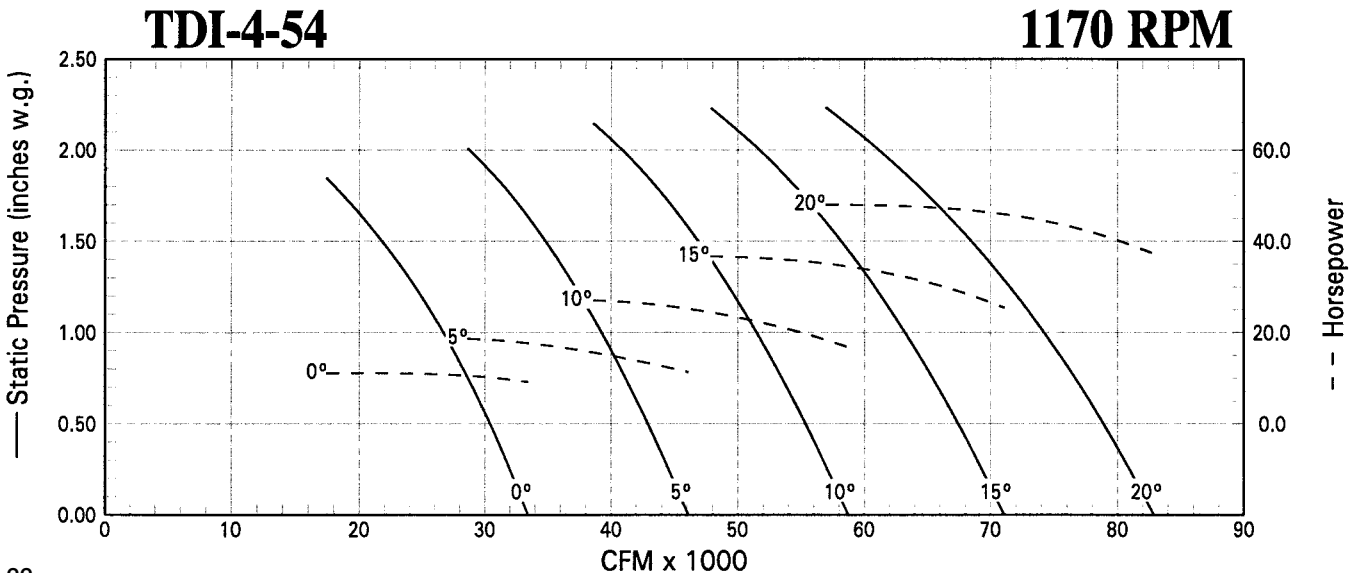
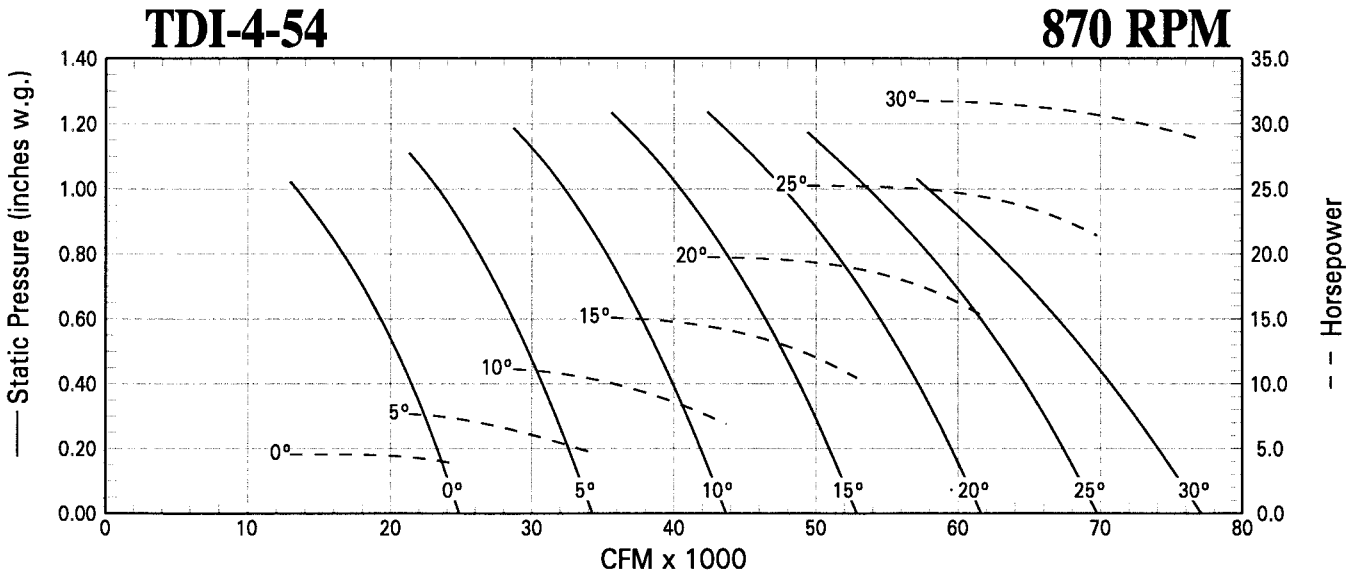

Shown with optional mounting brackets

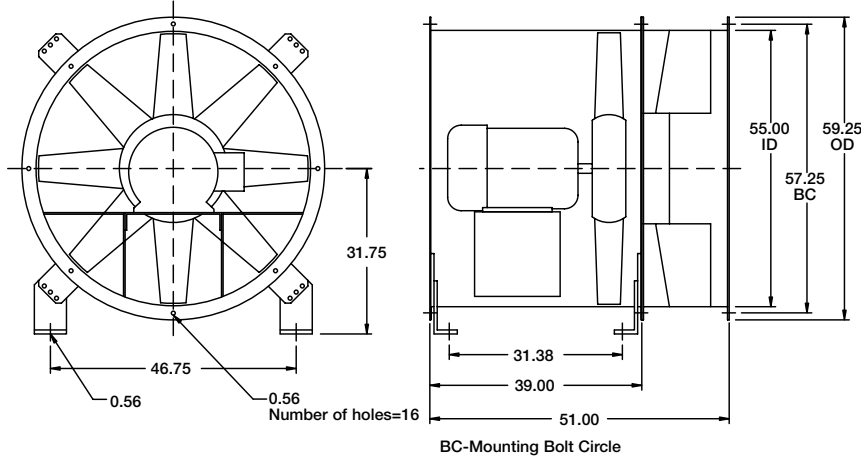

Specifications

- Max Fan RPM = 1170
- Max Motor Frame size = 365T
- Min Motor Frame size = 254T
- Fan Tube Gauge = 3/16 in.
- Approx. Weight (LM) = 950 lbs.
- Number of Blades = 12

Outlet Velocity (FPM) = CFM / 16.50 ft²
Tip Speed = Fan RPM x 14.14

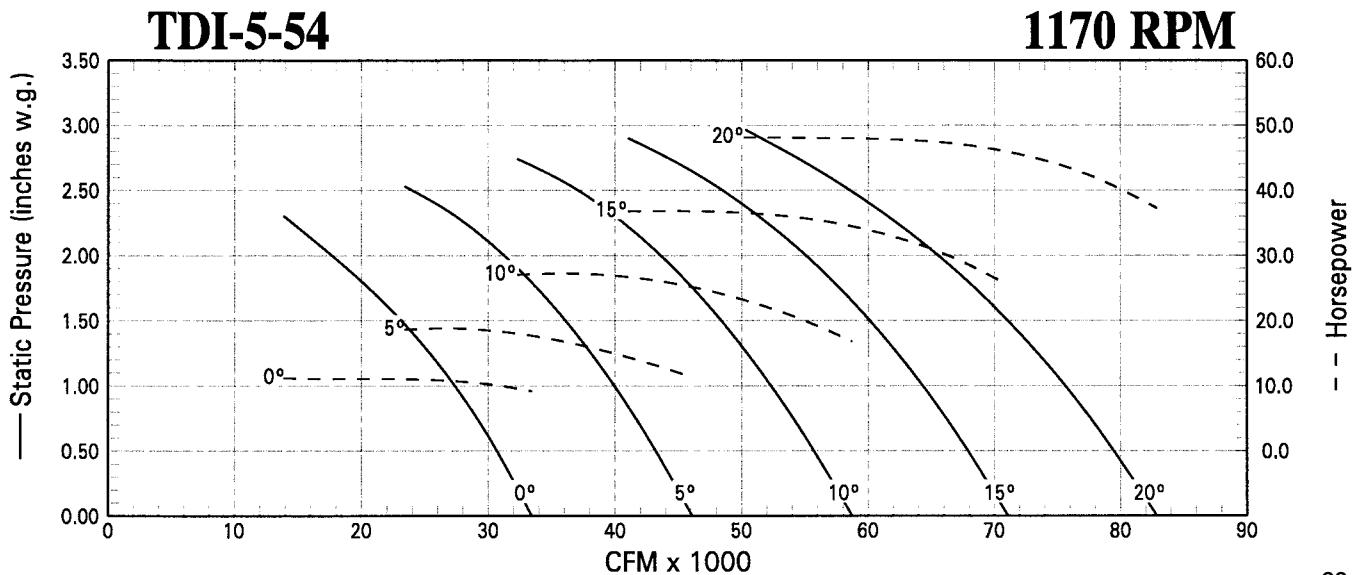
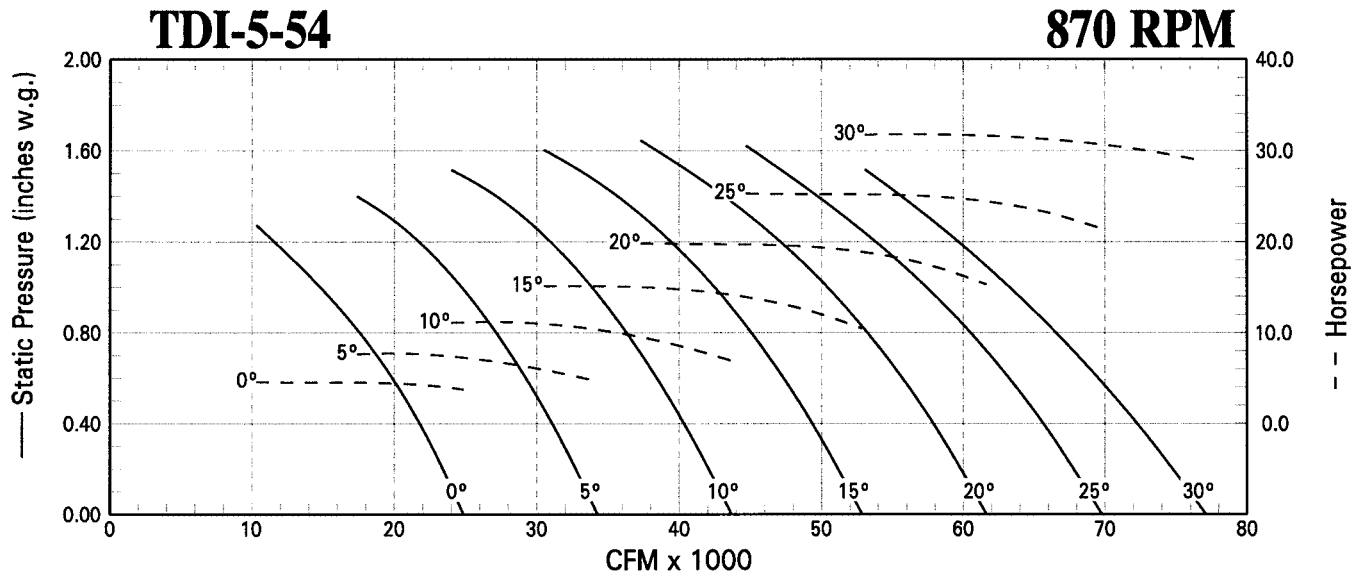

TDI Size 60

Direct Drive Level 4



Shown with optional mounting brackets

Air Flow →

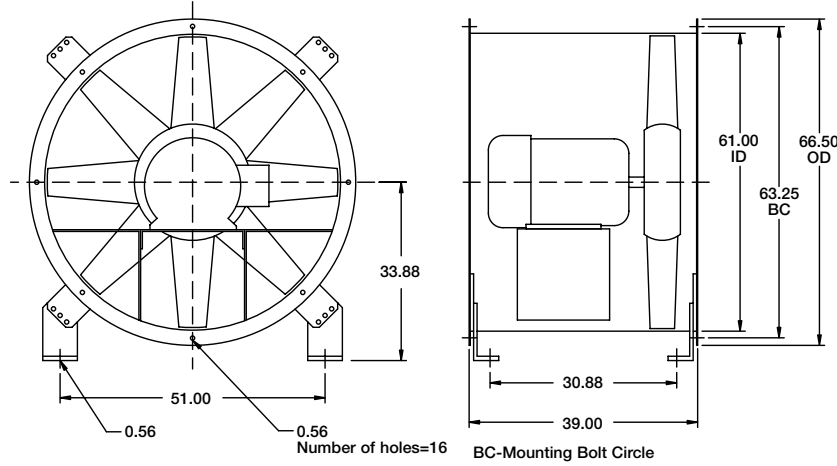

Specifications

- Max Fan RPM = 870
- Max Motor Frame size = 365T
- Min Motor Frame size = 256T
- Fan Tube Gauge = 1/4 in.
- Approx. Weight (LM) = 965 lbs.
- Number of Blades = 14

Outlet Velocity (FPM) = CFM / 20.30 ft²
 Tip Speed = Fan RPM x 15.71

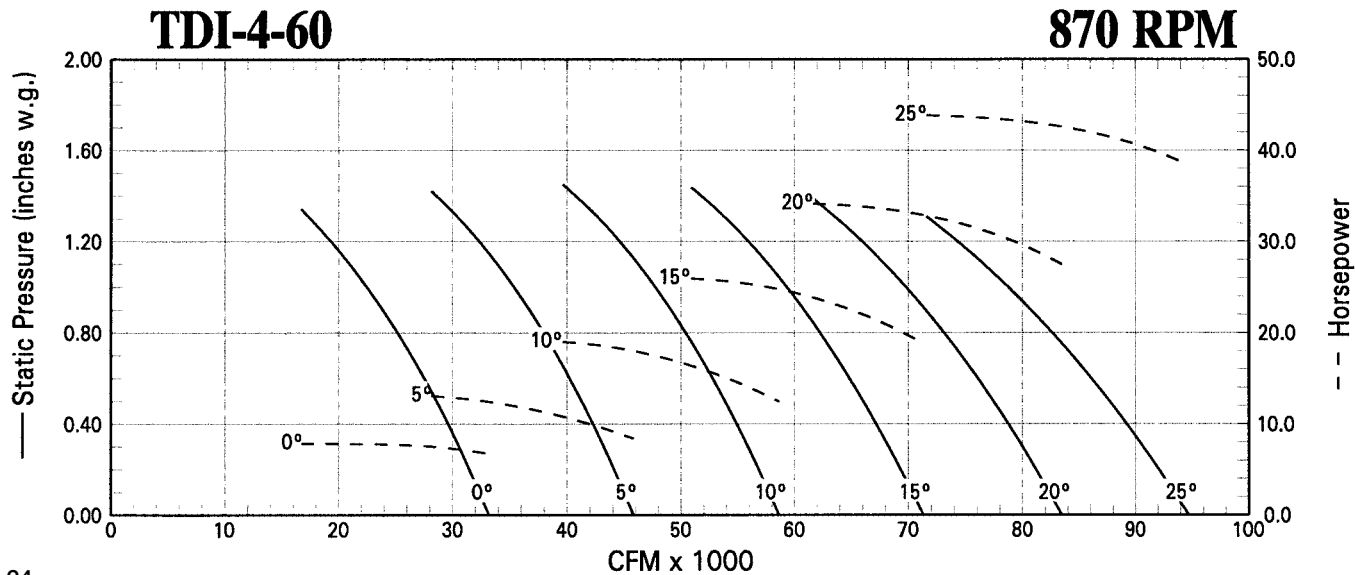
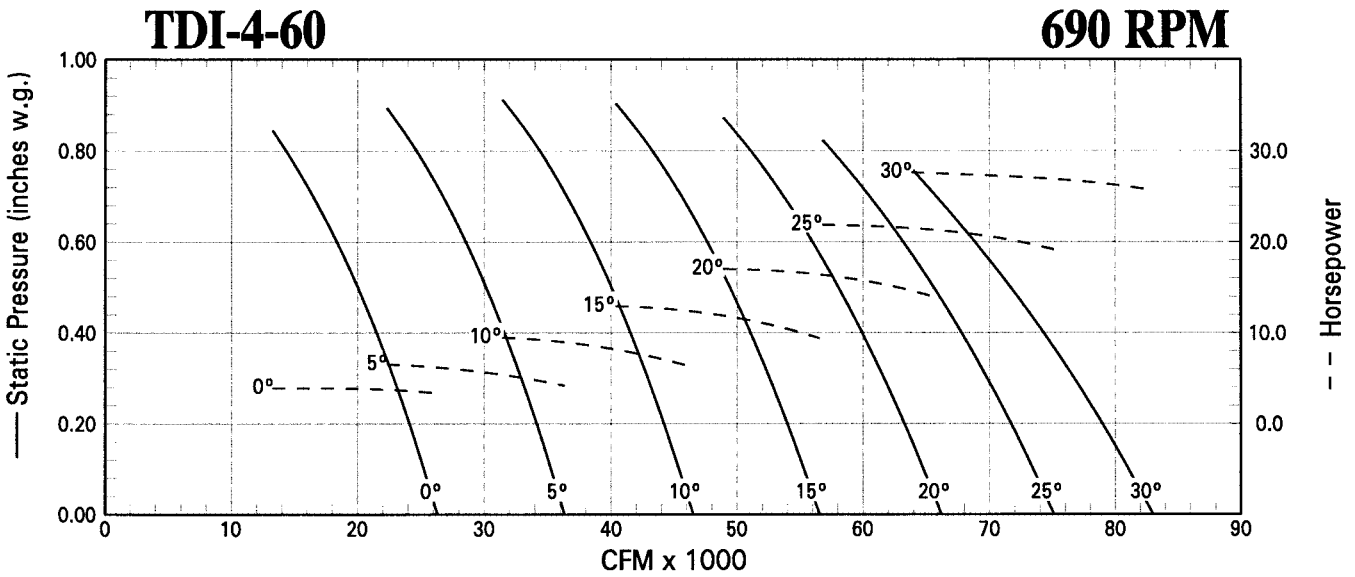

Shown with optional mounting brackets

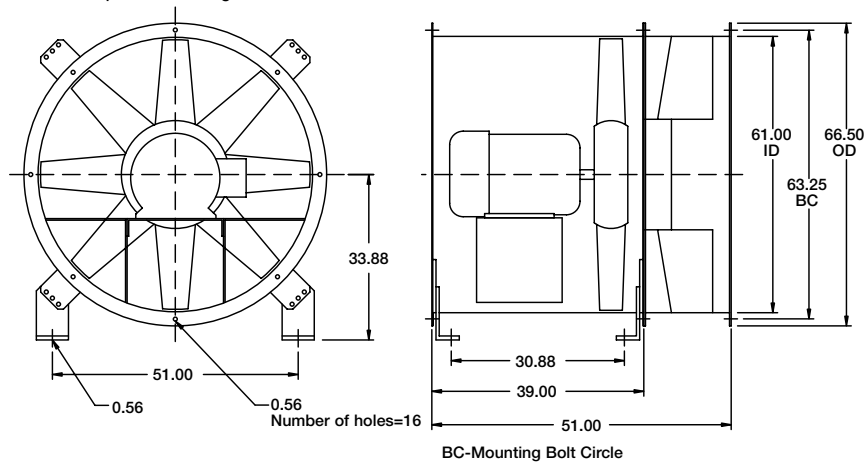

Specifications

- Max Fan RPM = 870
- Max Motor Frame size = 365T
- Min Motor Frame size = 256T
- Fan Tube Gauge = 1/4 in.
- Approx. Weight (LM) = 1220 lbs.
- Number of Blades = 14

Outlet Velocity (FPM) = CFM / 20.30 ft²
Tip Speed = Fan RPM x 15.71

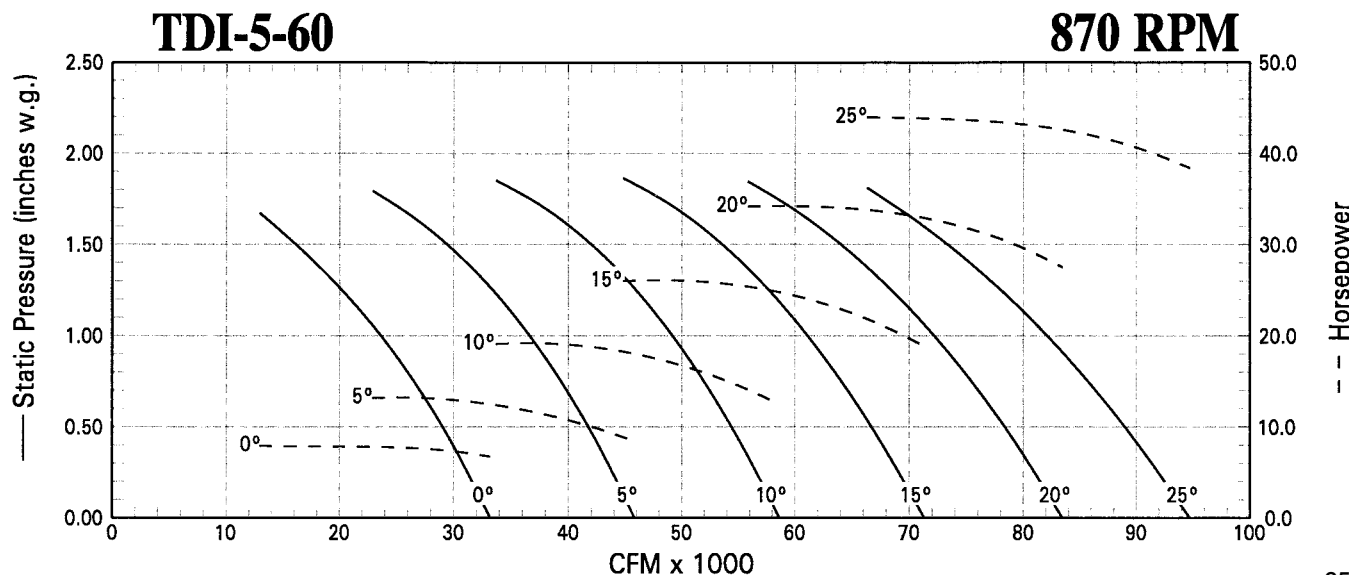
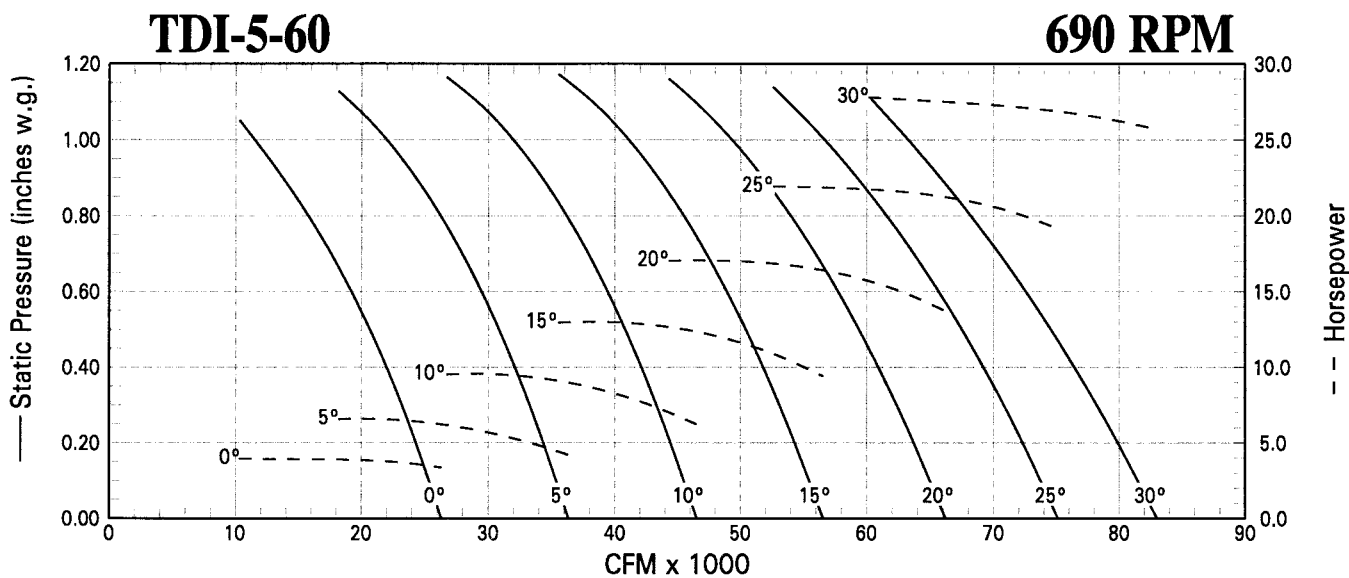

TBI-CA Size 18

Belt Drive Level 4



Shown with optional mounting brackets

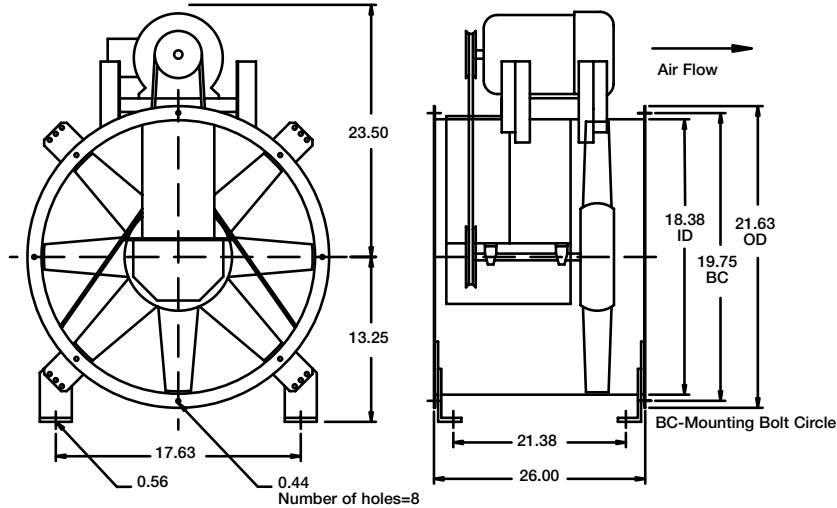

Specifications

- Max Fan RPM - L = 2666
- Max Fan RPM - H = 2700
- Max Motor Frame Size = 184T
- Fan Tube Gauge = 10 ga.
- Approx. Weight (LM) = 195 lbs.
- Number of Blades = 8

Outlet Velocity (fpm) = CFM / 1.84 ft²
 Tip Speed (fpm) = Fan RPM x 4.71

TBI-CA Performance Data - Level 4

Optimum selection for propeller type shown in bold.

Model Number	Motor HP	Fan RPM	Max BHP	* L _{wi} A	** dBA	Static Pressure in Inches WG / CFM										
						0.000	0.25	0.50	0.75	1.00	1.25	1.50	1.75	2.00	2.25	2.50
						CFM	CFM	CFM	CFM	CFM	CFM	CFM	CFM	CFM	CFM	CFM
4H18-3	1/3	1279	0.33	78	67	1948	1795	1581								
4H18-3	1/3	1321	0.35	81	69	2012	1864	1666								
4L18-5	1/2	1237	0.50	77	66	2762	2475	2114								
4L18-5	1/2	1277	0.55	80	69	2852	2575	2237								
4H18-5	1/2	1465	0.50	83	72	2231	2101	1940	1713							
4H18-5	1/2	1512	0.54	84	73	2303	2177	2026	1820							
4L18-7	3/4	1416	0.75	84	73	3162	2917	2634	2262							
4L18-7	3/4	1461	0.82	85	74	3262	3025	2755	2416							
4H18-7	3/4	1676	0.75	86	75	2553	2442	2312	2156	1941						
4H18-7	3/4	1730	0.81	87	75	2635	2529	2404	2257	2065						
4L18-10	1	1558	1.00	86	75	3479	3258	3012	2722							
4L18-10	1	1608	1.10	87	76	3591	3377	3143	2870							
4H18-10	1	1845	1.00	87	76	2810	2711	2598	2469	2309	2097					
4H18-10	1	1904	1.09	87	76	2900	2804	2696	2574	2428	2241					
4L18-15	1 1/2	1783	1.50	88	77	3981	3791	3584	3358	3094						
4L18-15	1 1/2	1841	1.64	89	78	4111	3927	3729	3512	3269	2965					
4H18-15	1 1/2	2111	1.50	88	77	3215	3129	3035	2931	2815	2679	2512				
4H18-15	1 1/2	2180	1.65	88	77	3320	3237	3147	3049	2939	2814	2666	2473			
4L18-20	2	1963	2.00	89	78	4383	4212	4029	3832	3615	3365					
4L18-20	2	2026	2.20	89	78	4524	4358	4182	3993	3789	3558	3280				
4H18-20	2	2324	2.00	89	78	3539	3461	3380	3289	3190	3081	2958	2811	2627		
4H18-20	2	2399	2.18	89	78	3654	3578	3500	3412	3318	3218	3103	2971	2813		
4L18-30	3	2246	3.00	90	79	5015	4865	4709	4545	4371	4185	3978	3739			
4L18-30	3	2319	3.29	90	79	5178	5033	4883	4726	4559	4381	4187	3970	3717		
4H18-30	3	2660	3.00	89	78	4051	3983	3914	3838	3759	3672	3583	3479	3368	3243	3095
4H18-30	3	2700	3.10	89	78	4112	4045	3977	3903	3825	3741	3653	3554	3448	3327	3186
4L18-50	5	2665	5.00	91	80	5951	5825	5698	5563	5426	5280	5129	4972	4798	4611	4403

Performance shown is for installation type B: free inlet, ducted outlet. Power rating (Bhp) does not include drive losses. Performance ratings do not include the effects of appurtenances in the airstream.

The sound power level ratings shown are in decibels, referred to 10⁻¹² watts calculated per AMCA Standard 301. Values shown are for inlet L_{wi}A sound power levels for installation type B: free inlet, ducted outlet. Ratings do not include the effects of end correction.

* Sound power values listed are at 0.50 inches pressure wg for each rpm.

** dBA sound pressure values are weighted with 11.5 dB attenuation for each octave band at 5 feet. Listed sound pressure value is for each rpm at 0.50 inches wg.

Shown with optional mounting brackets

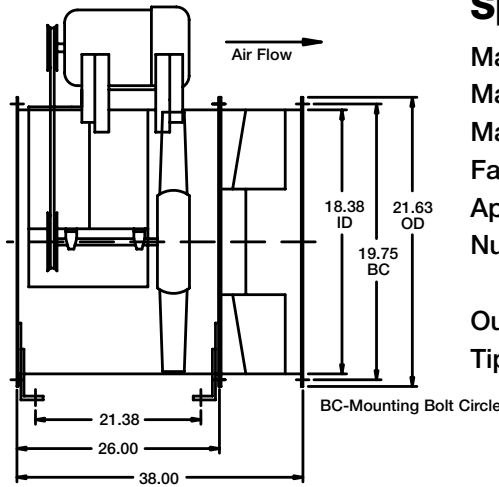
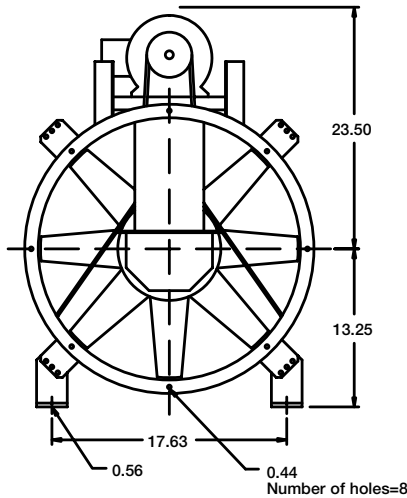

Specifications

- Max Fan RPM - L = 2666
- Max Fan RPM - H = 2700
- Max Motor Frame Size = 184T
- Fan Tube Gauge = 10 ga.
- Approx. Weight (LM) = 235 lbs.
- Number of Blades = 8

Outlet Velocity (fpm) = CFM / 1.84 ft²
Tip Speed (fpm) = Fan RPM x 4.71

TBI-CA Performance Data - Level 5

Optimum selection for propeller type shown in bold.

Model Number	Motor HP	Fan RPM	Max BHP	* L _{wi} A	** dBA	Static Pressure in Inches WG / CFM														
						0.50	0.75	1.00	1.25	1.50	1.75	2.00	2.25	2.50	2.75	3.00				
						CFM	CFM	CFM	CFM	CFM	CFM	CFM	CFM	CFM	CFM	CFM				
5L18-3	1/3	1081	0.33	74	63	1783														
5L18-3	1/3	1116	0.37	77	66	1893														
5H18-3	1/3	1277	0.33	78	67	1628	1328													
5H18-3	1/3	1318	0.37	79	68	1707	1446													
5L18-5	1/2	1239	0.5	81	70	2258	1875													
5L18-5	1/2	1279	0.55	82	71	2370	2025													
5H18-5	1/2	1463	0.5	82	70	1972	1788	1492												
5H18-5	1/2	1510	0.55	84	73	2056	1885	1636												
5L18-7	3/4	1417	0.75	85	74	2739	2475	2105												
5L18-7	3/4	1463	0.83	85	74	2859	2610	2288												
5H18-7	3/4	1674	0.75	85	74	2335	2201	2033	1788											
5H18-7	3/4	1728	0.83	86	75	2426	2299	2144	1941											
5L18-10	1	1559	1.00	86	75	3105	2882	2617	2241											
5L18-10	1	1610	1.10	86	75	3233	3024	2777	2464											
5H18-10	1	1843	1.00	86	75	2617	2507	2375	2213	1985										
5H18-10	1	1903	1.10	86	75	2717	2610	2486	2338	2150	1857									
5L18-15	1 1/2	1785	1.50	87	76	3663	3484	3285	3058	2777										
5L18-15	1 1/2	1843	1.65	88	77	3803	3633	3448	3237	2987	2644									
5H18-15	1 1/2	2109	1.50	87	76	3053	2959	2860	2745	2611	2450	2238								
5H18-15	1 1/2	2177	1.65	87	76	3161	3072	2979	2870	2750	2610	2432	2175							
5L18-20	2	1965	2.00	88	77	4097	3943	3772	3587	3379	3134	2804								
5L18-20	2	2028	2.20	88	77	4248	4098	3937	3764	3573	3354	3083								
5H18-20	2	2322	2.00	88	77	3392	3313	3226	3133	3028	2911	2778	2613	2391						
5H18-20	2	2396	2.20	88	77	3509	3435	3350	3266	3165	3061	2934	2789	2611	2366					
5L18-30	3	2249	3.00	90	78	4772	4638	4503	4354	4200	4028	3840	3629	3366						
5L18-30	3	2321	3.30	89	78	4941	4812	4681	4540	4394	4233	4063	3871	3645	3363					
5H18-30	3	2657	3.00	88	77	3920	3857	3785	3709	3633	3544	3452	3349	3236	3103	2952				
5H18-30	3	2700	3.14	88	77	3988	3925	3856	3781	3706	3622	3532	3436	3325	3204	3062				
5L18-50	5	2666	5.00	90	79	5742	5637	5523	5409	5291	5164	5037	4896	4751	4592	4425				

Performance shown is for installation type B: free inlet, ducted outlet. Power rating (Bhp) does not include drive losses. Performance ratings do not include the effects of appurtenances in the airstream.

The sound power level ratings shown are in decibels, referred to 10⁻¹² watts calculated per AMCA Standard 301. Values shown are for inlet L_{wi}A sound power levels for installation type B: free inlet, ducted outlet. Ratings do not include the effects of end correction.

* Sound power values listed are at 0.50 inches pressure wg for each rpm.

** dBA sound pressure values are weighted with 11.5 dB attenuation for each octave band at 5 feet. Listed sound pressure value is for each rpm at 0.50 inches wg.

TBI-CA Size 20

Belt Drive Level 4

Shown with optional mounting brackets

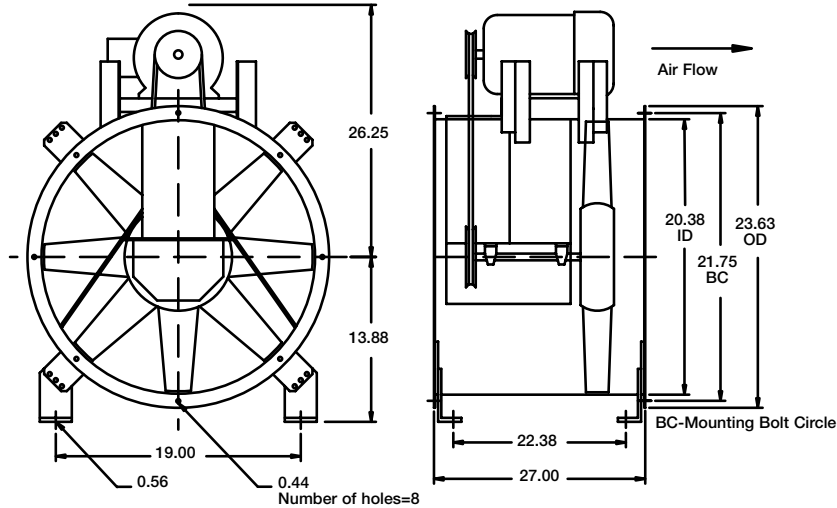

Specifications

- Max Fan RPM - L = 2634
- Max Fan RPM - H = 2700
- Max Motor Frame Size = 213T
- Fan Tube Gauge = 10 ga.
- Approx. Weight (LM) = 210 lbs.
- Number of Blades = 8

Outlet Velocity (fpm) = CFM / 2.26 ft²
 Tip Speed (fpm) = Fan RPM x 5.24

TBI-CA Performance Data - Level 4

Optimum selection for propeller type shown in bold.

Model Number	Motor HP	Fan RPM	Max BHP	* L _{wi} A	** dBA	Static Pressure in Inches WG / CFM										
						0.000	0.25	0.50	0.75	1.00	1.25	1.50	1.75	2.00	2.25	2.50
						CFM	CFM	CFM	CFM	CFM	CFM	CFM	CFM	CFM	CFM	CFM
4H20-5	1/2	1342	0.5	83	72	2829	2637	2392	2012							
4H20-5	1/2	1355	0.55	72	72	2856	2666	2425	2059							
4L20-7	3/4	1223	0.75	83	72	4101	3700	3177								
4L20-7	3/4	1263	0.83	84	73	4235	3851	3356								
4H20-7	3/4	1526	0.75	77	75	3217	3052	2857	2605							
4H20-7	3/4	1549	0.83	86	75	3265	3104	2912	2671	2321						
4L20-10	1	1348	1.00	85	74	4520	4163	3727	3129							
4L20-10	1	1390	1.10	86	75	4661	4316	3901	3355							
4H20-10	1	1667	1.00	88	77	3514	3367	3195	2990	2724						
4H20-10	1	1729	1.10	88	77	3645	3503	3342	3151	2914						
4L20-15	1 1/2	1541	1.50	89	78	5167	4861	4509	4085							
4L20-15	1 1/2	1591	1.65	89	78	5335	5040	4703	4306	3799						
4H20-15	1 1/2	1897	1.50	89	78	3999	3870	3727	3566	3380	3150	2843				
4H20-15	1 1/2	1959	1.65	89	78	4130	4005	3868	3715	3541	3332	3066				
4L20-20	2	1695	2.00	90	79	5683	5410	5102	4747	4325						
4L20-20	2	1750	2.20	90	79	5868	5605	5310	4973	4585	4093					
4H20-20	2	2085	2.00	89	78	4395	4278	4153	4016	3862	3685	3473	3200			
4H20-20	2	2162	2.20	83	79	4557	4444	4326	4195	4049	3886	3696	3466			
4L20-30	3	1940	3.00	91	80	6505	6268	6011	5727	5410	5052	4607				
4L20-30	3	2003	3.30	91	80	6716	6486	6239	5969	5670	5334	4938				
4H20-30	3	2390	3.00	91	73	5038	4936	4834	4716	4595	4461	4313	4147	3955	3721	
4H20-30	3	2461	3.30	91	80	5188	5088	4989	4877	4762	4633	4496	4344	4166	3961	3713
4L20-50	5	2300	5.00	92	81	7712	7512	7306	7084	6843	6586	6308	5999	5638		
4L20-50	5	2375	5.51	93	81	7963	7770	7573	7358	7130	6890	6622	6333	6009	5637	
4L20-75	7 1/2	2633	7.50	93	82	8828	8654	8479	8290	8096	7887	7670	7432	7185	6914	6608

Performance shown is for installation type B: free inlet, ducted outlet. Power rating (Bhp) does not include drive losses. Performance ratings do not include the effects of appurtenances in the airstream.

The sound power level ratings shown are in decibels, referred to 10⁻¹² watts calculated per AMCA Standard 301. Values shown are for inlet L_{wi}A sound power levels for installation type B: free inlet, ducted outlet. Ratings do not include the effects of end correction.

* Sound power values listed are at 0.50 inches pressure wg for each rpm.

** dBA sound pressure values are weighted with 11.5 dB attenuation for each octave band at 5 feet. Listed sound pressure value is for each rpm at 0.50 inches wg.

Shown with optional mounting brackets

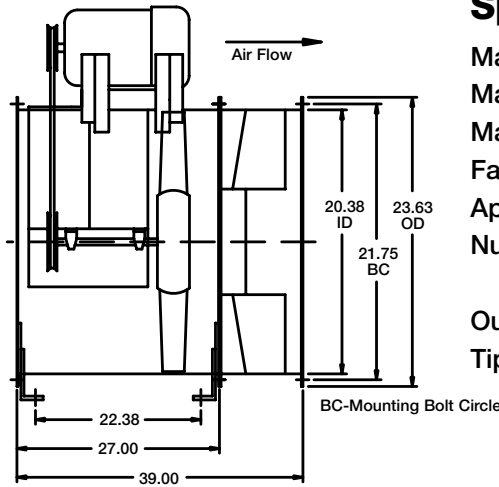
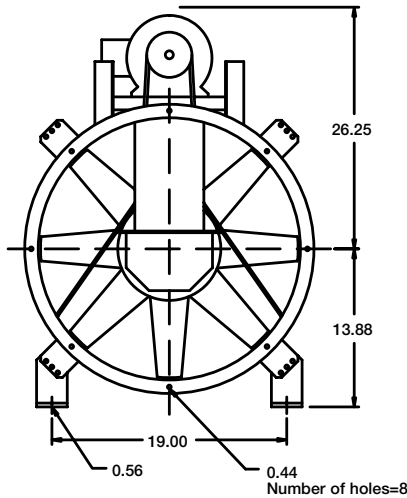

Specifications

- Max Fan RPM - L = 2634
- Max Fan RPM - H = 2700
- Max Motor Frame Size = 213T
- Fan Tube Gauge = 10 ga.
- Approx. Weight (LM) = 255 lbs.
- Number of Blades = 8

Outlet Velocity (fpm) = CFM / 2.26 ft²
Tip Speed (fpm) = Fan RPM x 5.24

TBI-CA Performance Data - Level 5

Optimum selection for propeller type shown in bold.

Model Number	Motor HP	Fan RPM	Max BHP	* L _{wi} A	** dBA	Static Pressure in Inches WG / CFM														
						0.50	0.75	1.00	1.25	1.50	1.75	2.00	2.25	2.50	2.75	3.00				
						CFM	CFM	CFM	CFM	CFM	CFM	CFM	CFM	CFM	CFM	CFM				
5L20-5	1/2	1068	0.50	76	65	2671														
5L20-5	1/2	1102	0.55	79	67	2839														
5H20-5	1/2	1317	0.50	82	71	2383	2070													
5H20-5	1/2	1365	0.55	82	71	2505	2229													
5L20-7	3/4	1224	0.75	83	72	3380	2828													
5L20-7	3/4	1263	0.83	84	73	3541	3044													
5H20-7	3/4	1506	0.75	86	75	2852	2639	2341												
5H20-7	3/4	1549	0.83	86	75	2954	2753	2484	2066											
5L20-10	1	1346	1.00	86	75	3877	3460	2850												
5L20-10	1	1390	1.10	87	75	4052	3659	3130												
5H20-10	1	1654	1.00	87	75	3199	3023	2804	2515											
5H20-10	1	1704	1.10	87	76	3315	3149	2948	2685	2298										
5L20-15	1 1/2	1540	1.50	88	77	4630	4309	3925	3417											
5L20-15	1 1/2	1590	1.65	88	77	4817	4513	4158	3708											
5H20-15	1 1/2	1889	1.50	88	77	3740	3598	3437	3250	3016	2705									
5H20-15	1 1/2	1951	1.65	88	77	3881	3744	3595	3426	3217	2952	2572								
5L20-20	2	1696	2.00	89	78	5210	4938	4627	4260	3796										
5L20-20	2	1750	2.20	89	78	5408	5152	4860	4524	4109	3556									
5H20-20	2	2080	2.00	88	77	4168	4044	3915	3761	3590	3388	3133	2780							
5H20-20	2	2147	2.20	89	77	4316	4199	4074	3932	3780	3591	3369	3088							
5L20-30	3	1941	3.00	90	79	6103	5876	5633	5368	5064	4709	4281								
5L20-30	3	2004	3.30	90	79	6330	6110	5883	5628	5345	5026	4649	4170							
5H20-30	3	2381	3.00	90	79	4830	4735	4622	4509	4381	4244	4086	3915	3701	3443	3109				
5H20-30	3	2456	3.30	90	79	4994	4903	4795	4686	4570	4437	4300	4134	3950	3740	3472				
5L20-50	5	2301	5.00	91	80	7376	7199	7007	6815	6593	6371	6114	5842	5532	5167	4724				
5L20-50	5	2375	5.50	92	81	7635	7467	7281	7096	6889	6675	6441	6192	5907	5595	5231				
5L20-75	7 1/2	2634	7.50	92	81	8536	8388	8229	8062	7895	7714	7521	7327	7107	6883	6632				

Performance shown is for installation type B: free inlet, ducted outlet. Power rating (Bhp) does not include drive losses. Performance ratings do not include the effects of appurtenances in the airstream.

The sound power level ratings shown are in decibels, referred to 10⁻¹² watts calculated per AMCA Standard 301. Values shown are for inlet L_{wi}A sound power levels for installation type B: free inlet, ducted outlet. Ratings do not include the effects of end correction.

* Sound power values listed are at 0.50 inches pressure wg for each rpm.

** dBA sound pressure values are weighted with 11.5 dB attenuation for each octave band at 5 feet. Listed sound pressure value is for each rpm at 0.50 inches wg.

TBI-CA Size 24

Belt Drive Level 4



Shown with optional mounting brackets

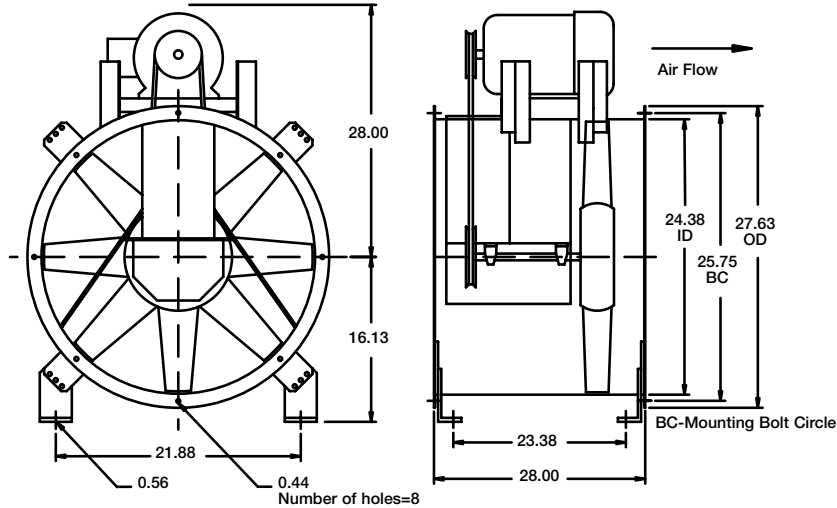

Specifications

- Max Fan RPM - L = 2250
- Max Fan RPM - H = 2678
- Max Motor Frame Size = 215T
- Fan Tube Gauge = 10 ga.
- Approx. Weight (LM) = 255 lbs.
- Number of Blades = 8

Outlet Velocity (fpm) = CFM / 3.21 ft²
 Tip Speed (fpm) = Fan RPM x 6.28

TBI-CA Performance Data - Level 4

Optimum selection for propeller type shown in bold.

Model Number	Motor HP	Fan RPM	Max BHP	* L _{wi} A	** dBA	Static Pressure in Inches WG / CFM										
						0.000	0.25	0.50	0.75	1.00	1.25	1.50	1.75	2.00	2.25	2.50
						CFM	CFM	CFM	CFM	CFM	CFM	CFM	CFM	CFM	CFM	CFM
4L24-7	3/4	973	0.75	80	69	6517	5744	4543								
4L24-7	3/4	978	0.83	80	69	6551	5783	4597								
4H24-7	3/4	1233	0.75	84	73	4900	4561	4122								
4H24-7	3/4	1266	0.85	85	73	5031	4702	4284								
4L24-10	1	1048	1.00	83	72	7020	6320	5322								
4L24-10	1	1084	1.10	83	72	7261	6594	5671								
4H24-10	1	1358	1.00	86	75	5397	5093	4727	4228							
4H24-10	1	1415	1.10	88	77	5623	5334	4992	4550							
4L24-15	1 1/2	1193	1.50	87	76	7991	7398	6641	5578							
4L24-15	1 1/2	1234	1.65	89	78	8265	7695	6982	6017							
4H24-15	1 1/2	1551	1.50	89	78	6164	5905	5607	5250	4783						
4H24-15	1 1/2	1616	1.65	90	79	6422	6176	5896	5563	5158						
4L24-20	2	1323	2.00	90	79	8861	8337	7711	6902							
4L24-20	2	1370	2.20	90	79	9176	8673	8077	7331							
4H24-20	2	1699	2.00	91	80	6752	6518	6258	5959	5597	5138					
4H24-20	2	1770	2.20	91	80	7034	6809	6562	6283	5960	5556					
4L24-30	3	1513	3.00	92	80	10134	9690	9174	8565	7827						
4L24-30	3	1553	3.30	92	81	10402	9970	9476	8895	8205	7340					
4H24-30	3	1934	3.02	92	81	7686	7480	7260	7020	6749	6437	6058	5579			
4H24-30	3	2007	3.30	93	81	7976	7778	7569	7345	7087	6800	6466	6057			
4L24-50	5	1789	5.00	94	83	11983	11607	11200	10747	10236	9647	8960				
4L24-50	5	1841	5.50	94	83	12331	11966	11574	11144	10661	10110	9469	8722			
4H24-50	5	2312	5.00	95	84	9188	9016	8844	8652	8457	8233	7996	7739	7437	7090	6671
4H24-50	5	2374	5.50	95	84	9434	9267	9099	8915	8726	8513	8291	8042	7764	7450	7078
4L24-75	7 1/2	2046	7.50	95	84	13704	13376	13039	12665	12259	11819	11332	10777	10151		
4L24-75	7 1/2	2109	8.26	96	85	14126	13808	13486	13123	12740	12326	11858	11345	10771	10120	
4L24-100	10	2250	10.01	96	85	15071	14772	14474	14141	13801	13418	13018	12575	12087	11551	10955

Performance shown is for installation type B: free inlet, ducted outlet. Power rating (Bhp) does not include drive losses. Performance ratings do not include the effects of appurtenances in the airstream.

The sound power level ratings shown are in decibels, referred to 10⁻¹² watts calculated per AMCA Standard 301. Values shown are for inlet L_{wi}A sound power levels for installation type B: free inlet, ducted outlet. Ratings do not include the effects of end correction.

* Sound power values listed are at 0.50 inches pressure wg for each rpm.

** dBA sound pressure values are weighted with 11.5 dB attenuation for each octave band at 5 feet. Listed sound pressure value is for each rpm at 0.50 inches wg.

Shown with optional mounting brackets

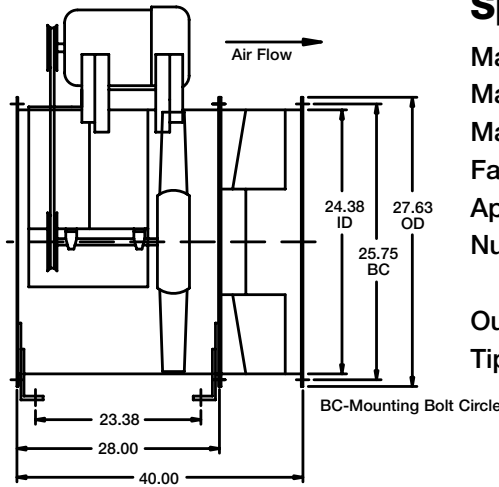
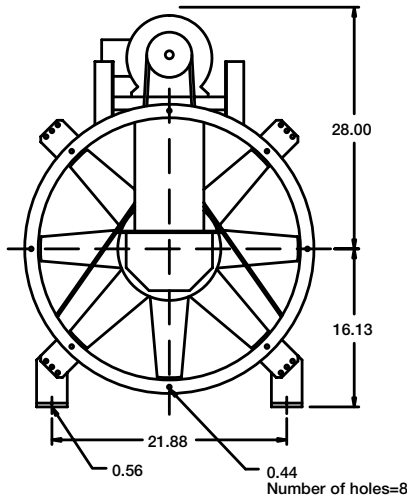

Specifications

- Max Fan RPM - L = 2250
- Max Fan RPM - H = 2678
- Max Motor Frame Size = 215T
- Fan Tube Gauge = 10 ga.
- Approx. Weight (LM) = 310 lbs.
- Number of Blades = 8

Outlet Velocity (fpm) = CFM / 3.21 ft²
Tip Speed (fpm) = Fan RPM x 6.28

TBI-CA Performance Data - Level 5

Optimum selection for propeller type shown in bold.

Model Number	Motor HP	Fan RPM	Max BHP	* L _{wi} A	** dBA	Static Pressure in Inches WG / CFM														
						0.50	0.75	1.00	1.25	1.50	1.75	2.00	2.25	2.50	2.75	3.00				
						CFM	CFM	CFM	CFM	CFM	CFM	CFM	CFM	CFM	CFM	CFM				
5L24-7	3/4	950	0.75	78	67	4718														
5L24-7	3/4	983	0.83	78	67	5045														
5H24-7	3/4	1218	0.75	82	71	4135	3557													
5H24-7	3/4	1268	0.83	83	71	4374	3868													
5L24-10	1	1041	1.00	83	72	5583	4374													
5L24-10	1	1075	1.10	84	73	5885	4805													
5H24-10	1	1328	1.00	85	74	4657	4218	3514												
5H24-10	1	1378	1.10	86	75	4890	4485	3904												
5L24-15	1 1/2	1192	1.50	87	75	6862	6061	4922												
5L24-15	1 1/2	1231	1.65	87	76	7174	6442	5419												
5H24-15	1 1/2	1526	1.50	89	78	5549	5228	4830	4259											
5H24-15	1 1/2	1587	1.65	89	78	5816	5518	5157	4687											
5L24-20	2	1315	2.00	90	79	7838	7193	6384												
5L24-20	2	1354	2.20	90	79	8133	7536	6777	5776											
5H24-20	2	1681	2.00	90	79	6224	5958	5647	5260	4733										
5H24-20	2	1725	2.20	90	79	6414	6159	5860	5502	5048	4365									
5L24-30	3	1502	3.00	91	80	9235	8741	8161	7459	6566										
5L24-30	3	1552	3.30	91	80	9603	9138	8601	7954	7163										
5H24-30	3	1920	3.00	91	80	7246	7019	6782	6510	6190	5805	5313								
5H24-30	3	1976	3.30	91	80	7479	7264	7041	6778	6487	6145	5716	5128							
5L24-50	5	1782	5.01	93	82	11275	10885	10472	10016	9481	8873	8156								
5L24-50	5	1838	5.50	93	82	11671	11299	10914	10472	9981	9428	8787	8021							
5H24-50	5	2269	5.00	93	82	8692	8526	8332	8138	7920	7689	7424	7137	6781	6358	5808				
5H24-50	5	2350	5.50	94	83	9025	8868	8684	8497	8299	8077	7849	7573	7274	6928	6496				
5L24-75	7 1/2	2038	7.50	94	83	13073	12763	12422	12069	11670	11246	10771	10235	9635	8944					
5L24-75	7 1/2	2104	8.26	95	84	13534	13242	12912	12581	12201	11815	11362	10885	10347	9728	9030				
5H24-75	7 1/2	2678	7.50	96	85	10367	10229	10092	9928	9764	9599	9417	9222	9027	8797	8554				
5L24-100	10	2247	10.00	95	84	14527	14265	13963	13654	13335	12973	12612	12188	11757	11254	10717				

Performance shown is for installation type B: free inlet, ducted outlet. Power rating (Bhp) does not include drive losses. Performance ratings do not include the effects of appurtenances in the airstream.

The sound power level ratings shown are in decibels, referred to 10⁻¹² watts calculated per AMCA Standard 301. Values shown are for inlet L_{wi}A sound power levels for installation type B: free inlet, ducted outlet. Ratings do not include the effects of end correction.

* Sound power values listed are at 0.50 inches pressure wg for each rpm.

** dBA sound pressure values are weighted with 11.5 dB attenuation for each octave band at 5 feet. Listed sound pressure value is for each rpm at 0.50 inches wg.

TBI-CA Size 30

Belt Drive Level 4



Shown with optional mounting brackets

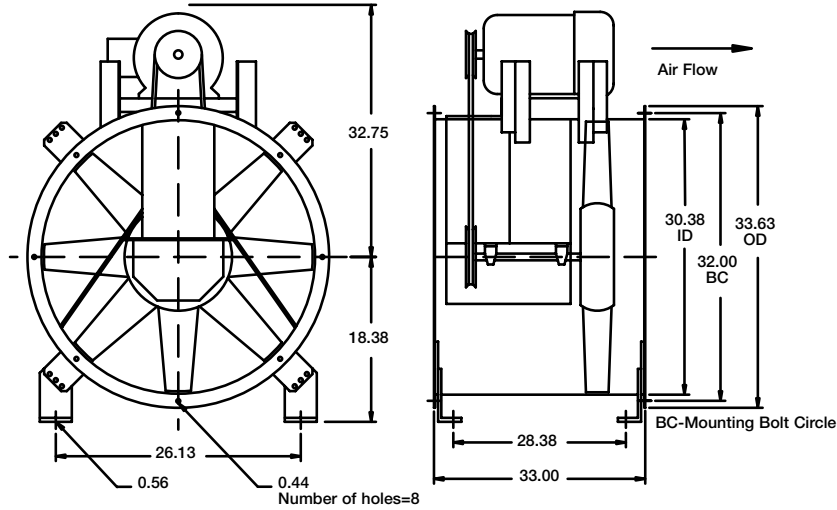

Specifications

- Max Fan RPM - L = 1814
- Max Fan RPM - H = 2145
- Max Motor Frame Size = 254T
- Fan Tube Gauge = 10 ga.
- Approx. Weight (LM) = 340 lbs.
- Number of Blades = 8

Outlet Velocity (fpm) = CFM / 5.07 ft²
 Tip Speed (fpm) = Fan RPM x 7.85

TBI-CA Performance Data - Level 4

Optimum selection for propeller type shown in bold.

Model Number	Motor HP	Fan RPM	Max BHP	* L _{wi} A	** dBA	Static Pressure in Inches WG / CFM										
						0.000	0.25	0.50	0.75	1.00	1.25	1.50	1.75	2.00	2.25	2.50
						CFM	CFM	CFM	CFM	CFM	CFM	CFM	CFM	CFM	CFM	CFM
4H30-10	1	932	1.00	81	70	8065	7111	5804								
4H30-10	1	969	1.10	83	72	8385	7473	6282								
4L30-15	1 1/2	855	1.52	83	72	11259	9731	7729								
4L30-15	1 1/2	866	1.65	83	72	11404	9899	7941								
4H30-15	1 1/2	1051	1.50	86	75	9094	8266	7249	5862							
4H30-15	1 1/2	1093	1.65	86	75	9458	8668	7721	6457							
4L30-20	2	929	2.00	83	72	12234	10852	9130								
4L30-20	2	962	2.20	85	74	12669	11346	9723								
4H30-20	2	1182	2.00	88	77	10228	9511	8668	7633							
4H30-20	2	1211	2.20	90	79	10479	9784	8972	7987	6732						
4L30-30	3	1057	3.00	89	78	13920	12730	11347	9656							
4L30-30	3	1094	3.30	89	78	14407	13262	11950	10362							
4H30-30	3	1350	3.00	91	80	11682	11059	10370	9579	8623						
4H30-30	3	1370	3.30	92	81	11855	11241	10565	9793	8880	7756					
4L30-50	5	1256	5.00	93	82	16540	15563	14475	13263	11828						
4L30-50	5	1300	5.50	93	82	17120	16182	15140	13987	12656						
4H30-50	5	1589	5.00	94	83	13750	13221	12670	12067	11384	10614	9721				
4H30-50	5	1624	5.50	94	83	14052	13535	13002	12412	11756	11024	10179	9220			
4L30-75	7 1/2	1441	7.51	94	83	18977	18135	17224	16241	15160	13917					
4L30-75	7 1/2	1481	8.28	95	84	19503	18685	17803	16855	15821	14659	13390				
4H30-75	7 1/2	1815	7.50	95	84	15705	15242	14779	14266	13738	13137	12494	11781	10963		
4H30-75	7 1/2	1863	8.25	95	84	16121	15670	15219	14726	14212	13644	13046	12356	11594	10760	
4L30-100	10	1587	10.01	95	84	20899	20135	19326	18464	17543	16532	15403				
4L30-100	10	1631	11.01	96	85	21479	20735	19954	19125	18244	17279	16213	15065			
4H30-100	10	1991	10.00	96	85	17228	16806	16384	15943	15462	14978	14420	13848	13202	12493	11725
4H30-100	10	2070	11.00	96	85	17912	17506	17100	16688	16225	15762	15253	14716	14128	13507	12794
4L30-150	15	1810	15.00	97	86	23836	23166	22485	21749	20981	20185	19313	18371	17365		

Performance shown is for installation type B: free inlet, ducted outlet. Power rating (Bhp) does not include drive losses. Performance ratings do not include the effects of appurtenances in the airstream.

The sound power level ratings shown are in decibels, referred to 10⁻¹² watts calculated per AMCA Standard 301. Values shown are for inlet L_{wi}A sound power levels for installation type B: free inlet, ducted outlet. Ratings do not include the effects of end correction.

* Sound power values listed are at 0.50 inches pressure wg for each rpm.

** dBA sound pressure values are weighted with 11.5 dB attenuation for each octave band at 5 feet. Listed sound pressure value is for each rpm at 0.50 inches wg.

Shown with optional mounting brackets

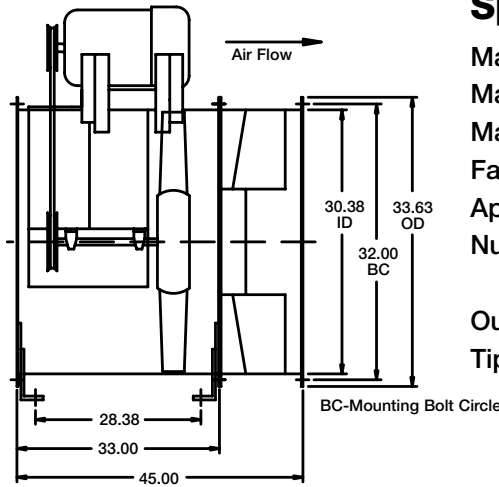
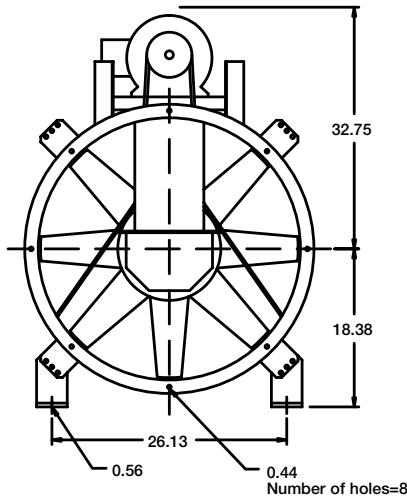

Specifications

- Max Fan RPM - L = 1804
- Max Fan RPM - H = 2145
- Max Motor Frame Size = 254T
- Fan Tube Gauge = 10 ga.
- Approx. Weight (LM) = 410 lbs.
- Number of Blades = 8

Outlet Velocity (fpm) = CFM / 5.07 ft²
Tip Speed (fpm) = Fan RPM x 7.85

TBI-CA Performance Data - Level 5

Optimum selection for propeller type shown in bold.

Model Number	Motor HP	Fan RPM	Max BHP	* L _{wi} A	** dBA	Static Pressure in Inches WG / CFM														
						0.50	0.75	1.00	1.25	1.50	1.75	2.00	2.25	2.50	2.75	3.00				
						CFM	CFM	CFM	CFM	CFM	CFM	CFM	CFM	CFM	CFM	CFM				
5L30-15	1 1/2	843	1.50	80	69	8184														
5L30-15	1 1/2	873	1.65	82	71	8742														
5H30-15	1 1/2	1063	1.50	84	73	7603	6479													
5H30-15	1 1/2	1078	1.65	85	73	7768	6675	5139												
5L30-20	2	920	2.00	85	74	9556	7726													
5L30-20	2	952	2.20	85	74	10101	8421													
5H30-20	2	1159	2.00	87	76	8606	7700	6492												
5H30-20	2	1201	2.28	88	77	9030	8181	7122	5670											
5L30-30	3	1052	3.00	88	77	11715	10392	8695												
5L30-30	3	1089	3.31	89	77	12294	11052	9503												
5H30-30	3	1316	3.01	91	80	10174	9467	8623	7563	6218										
5H30-30	3	1362	3.30	91	80	10625	9954	9163	8228	7023										
5L30-50	5	1253	5.00	92	81	14773	13787	12684	11384											
5L30-50	5	1287	5.50	92	81	15272	14325	13272	12063	10617										
5H30-50	5	1564	5.01	93	81	12548	11989	11404	10715	9951	9052	7959								
5H30-50	5	1611	5.51	93	82	12984	12453	11885	11245	10552	9729	8753	7602							
5L30-75	7 1/2	1431	7.51	93	82	17360	16557	15668	14703	13621	12363									
5L30-75	7 1/2	1473	8.27	94	83	17962	17182	16334	15423	14419	13266	11969								
5H30-75	7 1/2	1786	7.51	94	83	14592	14158	13646	13134	12556	11941	11234	10453	9542	8493					
5H30-75	7 1/2	1849	8.25	94	83	15166	14749	14269	13774	13255	12661	12042	11325	10514	9593					
5L30-100	10	1571	10.02	94	83	19358	18627	17868	17056	16165	15195	14103	12887							
5L30-100	10	1626	11.02	95	84	20132	19430	18717	17932	17106	16227	15222	14092							
5H30-100	10	1977	10.01	95	84	16328	15938	15522	15059	14597	14095	13539	12973	12303	11593	10781				
5H30-100	10	2053	11.01	95	84	17014	16639	16259	15813	15367	14922	14395	13860	13281	12636	11931				
5L30-150	15	1803	15.00	96	85	22589	21984	21347	20696	19989	19268	18475	17640	16730	15696					
5L30-150	15	1814	15.40	96	85	22714	22141	21508	20866	20163	19453	18665	17847	16943	15933	14880				

Performance shown is for installation type B: free inlet, ducted outlet. Power rating (Bhp) does not include drive losses. Performance ratings do not include the effects of appurtenances in the airstream.

The sound power level ratings shown are in decibels, referred to 10⁻¹² watts calculated per AMCA Standard 301. Values shown are for inlet L_{wi}A sound power levels for installation type B: free inlet, ducted outlet. Ratings do not include the effects of end correction.

* Sound power values listed are at 0.50 inches pressure wg for each rpm.

** dBA sound pressure values are weighted with 11.5 dB attenuation for each octave band at 5 feet. Listed sound pressure value is for each rpm at 0.50 inches wg.

TBI-CA Size 36

Belt Drive Level 4



Shown with optional mounting brackets

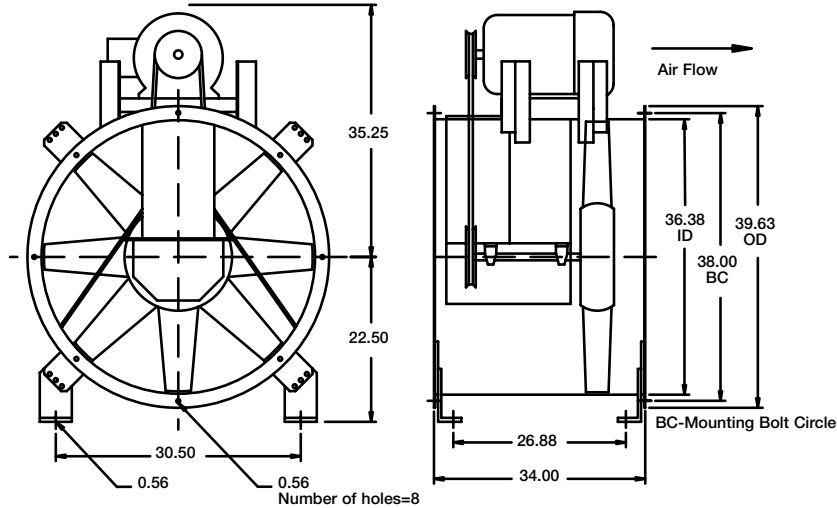

Specifications

- Max Fan RPM - L = 1639
- Max Fan RPM - H = 1791
- Max Motor Frame Size = 256T
- Fan Tube Gauge = 10 ga.
- Approx. Weight (LM) = 440 lbs.
- Number of Blades = 8

Outlet Velocity (fpm) = CFM / 7.22 ft²
 Tip Speed (fpm) = Fan RPM x 9.42

TBI-CA Performance Data - Level 4

Optimum selection for propeller type shown in bold.

Model Number	Motor HP	Fan RPM	Max BHP	* L _{wi} A	** dBA	Static Pressure in Inches WG / CFM										
						0.000	0.25	0.50	0.75	1.00	1.25	1.50	1.75	2.00	2.25	2.50
						CFM	CFM	CFM	CFM	CFM	CFM	CFM	CFM	CFM	CFM	CFM
4H36-15	1 1/2	819	1.50	84	73	12620	10981	8748								
4H36-15	1 1/2	850	1.65	84	73	13098	11533	9466								
4H36-20	2	918	2.00	87	76	14145	12721	10952								
4H36-20	2	953	2.20	90	79	14685	13318	11677								
4L36-30	3	875	3.00	86	75	18092	16222	13899								
4L36-30	3	906	3.30	88	77	18733	16943	14754								
4H36-30	3	1037	3.00	92	81	15979	14735	13311	11501							
4H36-30	3	1077	3.31	92	81	16595	15403	14060	12400							
4L36-50	5	1035	5.01	94	83	21401	19858	18092	15963							
4L36-50	5	1071	5.51	94	83	22145	20660	18985	17004							
4H36-50	5	1235	5.00	95	84	19030	18012	16893	15627	14132						
4H36-50	5	1273	5.68	96	85	19646	18660	17592	16397	14993	13362					
4L36-75	7 1/2	1184	7.51	96	85	24482	23156	21689	20050	18107						
4L36-75	7 1/2	1225	8.26	97	85	25329	24054	22651	21089	19299						
4H36-75	7 1/2	1396	7.51	96	85	21511	20610	19652	18615	17461	16129	14621				
4H36-75	7 1/2	1450	8.26	97	85	22343	21476	20561	19581	18507	17285	15883				
4L36-100	10	1301	10.00	97	86	26901	25708	24417	22988	21396	19575					
4L36-100	10	1347	11.02	97	86	27852	26700	25461	24114	22620	20923					
4H36-100	10	1542	10.00	98	87	23761	22945	22098	21208	20229	19155	17944	16594			
4H36-100	10	1601	11.00	98	87	24670	23884	23077	22221	21297	20303	19202	17957			
4L36-150	15	1495	15.00	99	88	30912	29874	28781	27617	26364	24999	23483				
4L36-150	15	1538	16.50	99	88	31801	30792	29737	28620	27426	26125	24709	23122			
4H36-150	15	1769	15.00	99	88	27259	26548	25837	25066	24286	23432	22534	21571	20471	19293	
4H36-150	15	1791	15.50	99	88	27598	26895	26193	25435	24671	23829	22957	22006	20944	19802	
4L36-200	20	1639	20.00	99	88	33890	32943	31968	30941	29836	28668	27420	26061	24565		

Performance shown is for installation type B: free inlet, ducted outlet. Power rating (Bhp) does not include drive losses. Performance ratings do not include the effects of appurtenances in the airstream.

The sound power level ratings shown are in decibels, referred to 10⁻¹² watts calculated per AMCA Standard 301. Values shown are for inlet L_{wi}A sound power levels for installation type B: free inlet, ducted outlet. Ratings do not include the effects of end correction.

* Sound power values listed are at 0.50 inches pressure wg for each rpm.

** dBA sound pressure values are weighted with 11.5 dB attenuation for each octave band at 5 feet. Listed sound pressure value is for each rpm at 0.50 inches wg.

Shown with optional mounting brackets

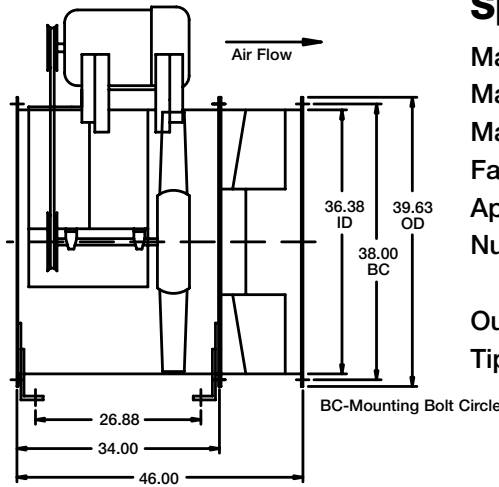
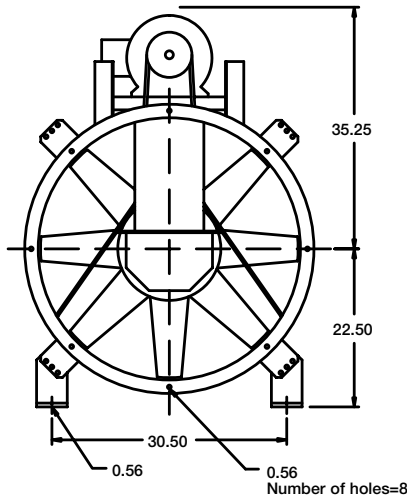

Specifications

- Max Fan RPM - L = 1639
- Max Fan RPM - H = 1791
- Max Motor Frame Size = 256T
- Fan Tube Gauge = 10 ga.
- Approx. Weight (LM) = 525 lbs.
- Number of Blades = 8

Outlet Velocity (fpm) = CFM / 7.22 ft²
Tip Speed (fpm) = Fan RPM x 9.42

TBI-CA Performance Data - Level 5

Optimum selection for propeller type shown in bold.

Model Number	Motor HP	Fan RPM	Max BHP	* L _{wi} A	** dBA	Static Pressure in Inches WG / CFM												
						0.50	0.75	1.00	1.25	1.50	1.75	2.00	2.25	2.50	2.75	3.00		
						CFM	CFM	CFM	CFM	CFM	CFM	CFM	CFM	CFM	CFM	CFM		
5L36-15	1 1/2	692	1.52	80	69	9276												
5L36-15	1 1/2	713	1.66	83	72	9975												
5H36-15	1 1/2	828	1.50	82	71	9517												
5H36-15	1 1/2	860	1.65	83	72	10199												
5L36-20	2	761	2.00	81	70	11520												
5L36-20	2	788	2.20	83	72	12303												
5H36-20	2	898	2.00	85	74	10994	8757											
5H36-20	2	929	2.20	87	76	11605	9634											
5L36-30	3	870	3.01	88	77	14551	12109											
5L36-30	3	898	3.30	88	77	15284	13026											
5H36-30	3	1027	3.00	86	75	13455	11932	9827										
5H36-30	3	1063	3.31	91	80	14120	12696	10851										
5L36-50	5	1032	5.01	92	81	18595	16934	14881										
5L36-50	5	1066	5.51	94	83	19410	17834	15977										
5H36-50	5	1225	5.00	94	83	16961	15866	14608	13068									
5H36-50	5	1257	5.50	94	83	17511	16463	15278	13844	12012								
5L36-75	7 1/2	1182	7.52	95	84	22110	20784	19297	17549									
5L36-75	7 1/2	1218	8.27	96	85	22932	21663	20253	18645	16716								
5H36-75	7 1/2	1397	7.51	95	84	19889	18980	17992	16907	15646	14095							
5H36-75	7 1/2	1438	8.26	96	85	20578	19695	18760	17754	16566	15182	13481						
5L36-100	10	1298	10.01	96	85	24745	23591	22342	20939	19326	17468							
5L36-100	10	1341	11.01	196	85	25712	24616	23414	22093	20620	18895							
5H36-100	10	1534	10.02	97	86	22165	21352	20525	19590	18597	17480	16149	14553					
5H36-100	10	1587	11.01	97	86	23031	22259	21459	20587	19676	18615	17439	16065					
5L36-150	15	1486	15.00	98	87	28941	27956	26935	25850	24653	23357	21904	20282					
5L36-150	15	1535	16.50	98	87	30018	29069	28104	27054	25941	24753	23419	21898					
5H36-150	15	1755	15.00	98	87	25756	25099	24375	23652	22860	22037	21133	20157	19031	17775	16332		
5H36-150	15	1791	15.90	98	87	26336	25702	24993	24284	23530	22723	21884	20927	19899	18746	17370		
5L36-200	20	1635	20.00	98	87	32191	31324	30429	29480	28494	27417	26292	25040	23635	22161			

Performance shown is for installation type B: free inlet, ducted outlet. Power rating (Bhp) does not include drive losses. Performance ratings do not include the effects of appurtenances in the airstream.

The sound power level ratings shown are in decibels, referred to 10⁻¹² watts calculated per AMCA Standard 301. Values shown are for inlet L_{wi}A sound power levels for installation type B: free inlet, ducted outlet. Ratings do not include the effects of end correction.

* Sound power values listed are at 0.50 inches pressure wg for each rpm.

** dBA sound pressure values are weighted with 11.5 dB attenuation for each octave band at 5 feet. Listed sound pressure value is for each rpm at 0.50 inches wg.

TBI-CA Size 42

Belt Drive Level 4



Shown with optional mounting brackets

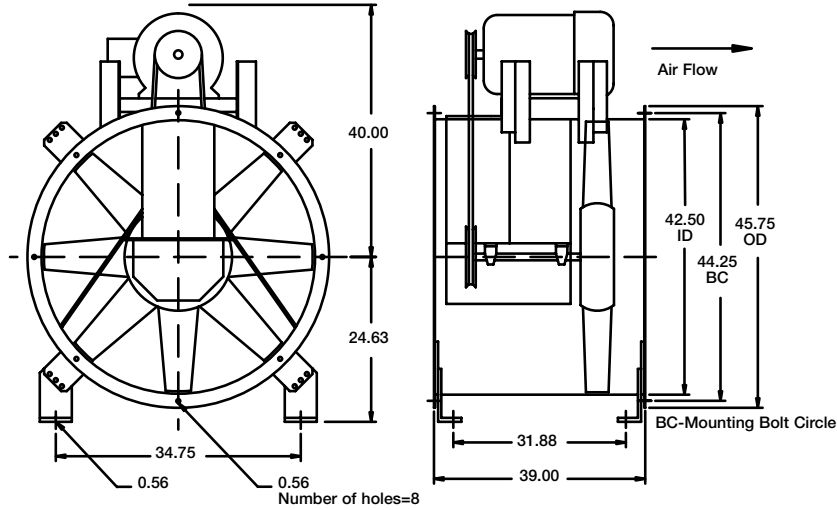

Specifications

- Max Fan RPM - L = 1351
- Max Fan RPM - H = 1540
- Max Motor Frame Size = 284T
- Fan Tube Gauge = 3/16
- Approx. Weight (LM) = 640 lbs.
- Number of Blades = 10

Outlet Velocity (fpm) = CFM / 9.85 ft²
 Tip Speed (fpm) = Fan RPM x 11.00

TBI-CA Performance Data - Level 4

Optimum selection for propeller type shown in bold.

Model Number	Motor HP	Fan RPM	Max BHP	* L _{wi} A	** dBA	Static Pressure in Inches WG / CFM										
						0.000	0.25	0.50	0.75	1.00	1.25	1.50	1.75	2.00	2.25	2.50
						CFM	CFM	CFM	CFM	CFM	CFM	CFM	CFM	CFM	CFM	CFM
4H42-20	2	696	2.00	87	76	16849	14823	11784								
4H42-20	2	722	2.20	88	77	17479	15553	12777								
4L42-30	3	666	3.01	88	77	22250	19494	15515								
4L42-30	3	689	3.30	89	77	23019	20379	16701								
4H42-30	3	814	3.00	93	82	19706	18047	15926	12787							
4H42-30	3	819	3.31	93	82	19827	18180	16082	13004							
4L42-50	5	802	5.00	95	84	26794	24618	21897								
4L42-50	5	815	5.52	95	84	27228	25091	22458	18966							
4H42-50	5	940	5.01	96	85	22756	21363	19706	17627	14768						
4H42-50	5	974	5.51	97	86	23580	22247	20672	18776	16233						
4L42-75	7 1/2	912	7.51	97	86	30469	28592	26406	23723							
4L42-75	7 1/2	936	8.31	97	86	31304	29486	27381	24839	21688						
4H42-75	7 1/2	1078	7.50	99	87	26122	24936	23592	22035	20135	17723					
4H42-75	7 1/2	1119	8.27	99	88	27090	25947	24665	23211	21491	19344					
4L42-100	10	999	10.00	99	88	33376	31692	29760	27539	24839						
4L42-100	10	1035	11.03	100	89	34578	32966	31126	29022	26546						
4H42-100	10	1188	10.02	100	89	28760	27683	26501	25179	23668	21883	19672				
4H42-100	10	1232	11.01	100	89	29825	28787	27662	26419	25019	23384	21427				
4L42-150	15	1146	15.00	101	90	38287	36840	35245	33474	31478	29153					
4L42-150	15	1177	16.50	101	90	39322	37913	36371	34669	32768	30609	28086				
4H42-150	15	1358	15.01	101	90	32876	31934	30957	29874	28684	27378	25900	24179	22124		
4H42-150	15	1408	16.50	101	90	34086	33178	32254	31209	30096	28903	27525	25972	24183		
4L42-200	20	1253	20.00	101	90	41861	40538	39116	37568	35866	33967	31823	29391			
4L42-200	20	1297	22.00	102	91	43331	42053	40694	39230	37633	35855	33881	31652			
4H42-200	20	1492	20.00	101	90	36120	35262	34405	33434	32443	31322	30126	28822	27310	25596	23600
4H42-200	20	1540	21.80	102	91	37306	36476	35646	34723	33769	32713	31620	30361	28989	27460	25707
4L42-250	25	1351	25.00	102	91	45136	43908	42623	41246	39721	38074	36266	34260	32015		

Performance shown is for installation type B: free inlet, ducted outlet. Power rating (Bhp) does not include drive losses. Performance ratings do not include the effects of appurtenances in the airstream.

The sound power level ratings shown are in decibels, referred to 10⁻¹² watts calculated per AMCA Standard 301. Values shown are for inlet L_{wi}A sound power levels for installation type B: free inlet, ducted outlet. Ratings do not include the effects of end correction.

* Sound power values listed are at 0.50 inches pressure wg for each rpm.

** dBA sound pressure values are weighted with 11.5 dB attenuation for each octave band at 5 feet. Listed sound pressure value is for each rpm at 0.50 inches wg.

Shown with optional mounting brackets

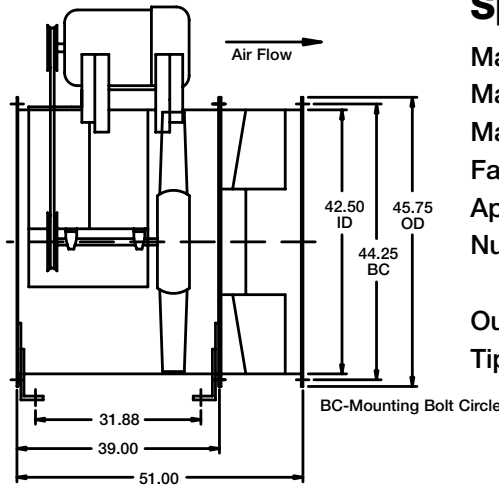
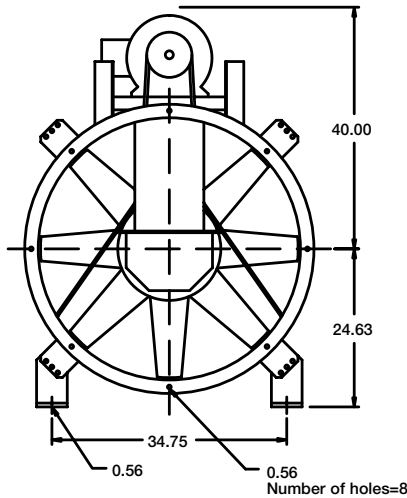

Specifications

- Max Fan RPM - L = 1351
- Max Fan RPM - H = 1540
- Max Motor Frame Size = 284T
- Fan Tube Gauge = 3/16
- Approx. Weight (LM) = 765 lbs.
- Number of Blades = 10

Outlet Velocity (fpm) = CFM / 9.85 ft²
Tip Speed (fpm) = Fan RPM x 11.00

TBI-CA Performance Data - Level 5

Optimum selection for propeller type shown in bold.

Model Number	Motor HP	Fan RPM	Max BHP	* L _{wi} A	** dBA	Static Pressure in Inches WG / CFM											
						0.50	0.75	1.00	1.25	1.50	1.75	2.00	2.25	2.50	2.75	3.00	
						CFM	CFM	CFM	CFM	CFM	CFM	CFM	CFM	CFM	CFM	CFM	
5L42-20	2	580	2.00	83	72	12224											
5L42-20	2	599	2.20	83	72	13357											
5H42-20	2	703	2.00	85	74	12806											
5H42-20	2	720	2.20	86	75	13391	9452										
5L42-30	3	670	3.00	89	78	16998											
5L42-30	3	694	3.31	89	78	18132											
5H42-30	3	795	3.00	91	80	15826	13166										
5H42-30	3	825	3.30	91	80	16735	14357										
5L42-50	5	792	5.01	95	84	22320	19446										
5L42-50	5	813	5.54	95	83	23163	20457	16850									
5H42-50	5	940	5.00	94	83	20070	18349	16080	12801								
5H42-50	5	968	5.50	97	86	20842	19209	17179	14343								
5L42-75	7 1/2	906	7.50	97	86	26823	24648	22041									
5L42-75	7 1/2	930	8.26	98	87	27745	25676	23201	20104								
5H42-75	7 1/2	1075	7.50	98	87	23751	22423	20857	18924	16405							
5H42-75	7 1/2	1111	8.25	98	87	24717	23463	21974	20230	18084	15077						
5L42-100	10	993	10.00	98	87	30166	28340	26239	23703	20593							
5L42-100	10	1024	11.02	99	88	31237	29494	27504	25179	22335							
5H42-100	10	1184	10.00	99	88	26660	25484	24186	22719	20979	18792	15907					
5H42-100	10	1220	11.00	99	88	27609	26470	25261	23888	22263	20337	17931					
5L42-150	15	1137	15.00	100	89	35364	33905	32246	30409	28319	25902						
5L42-150	15	1171	16.50	100	89	36593	35177	33603	31879	29942	27713	25109					
5H42-150	15	1353	15.00	100	89	31019	30066	29036	27915	26677	25258	23671	21795	19438			
5H42-150	15	1399	16.50	100	89	32189	31294	30299	29278	28081	26817	25370	23684	21705	19257		
5L42-200	20	1249	20.00	100	89	39396	38068	36677	35160	33462	31588	29476	27048				
5L42-200	20	1288	22.00	101	90	40777	39502	38195	36725	35147	33436	31497	29303	26795			
5H42-200	20	1489	20.00	100	89	34470	33680	32745	31809	30784	29659	28446	27087	25533	23780	21677	
5H42-200	20	1540	22.00	101	90	35756	34994	34119	33214	32293	31205	30117	28839	27525	25919	24127	
5L42-250	25	1344	25.02	101	90	42847	41657	40426	39066	37660	36053	34329	32435	30314	27869		

Performance shown is for installation type B: free inlet, ducted outlet. Power rating (Bhp) does not include drive losses. Performance ratings do not include the effects of appurtenances in the airstream.

The sound power level ratings shown are in decibels, referred to 10⁻¹² watts calculated per AMCA Standard 301. Values shown are for inlet L_{wi}A sound power levels for installation type B: free inlet, ducted outlet. Ratings do not include the effects of end correction.

* Sound power values listed are at 0.50 inches pressure wg for each rpm.

** dBA sound pressure values are weighted with 11.5 dB attenuation for each octave band at 5 feet. Listed sound pressure value is for each rpm at 0.50 inches wg.

TBI-CA Size 48

Belt Drive Level 4



Shown with optional mounting brackets

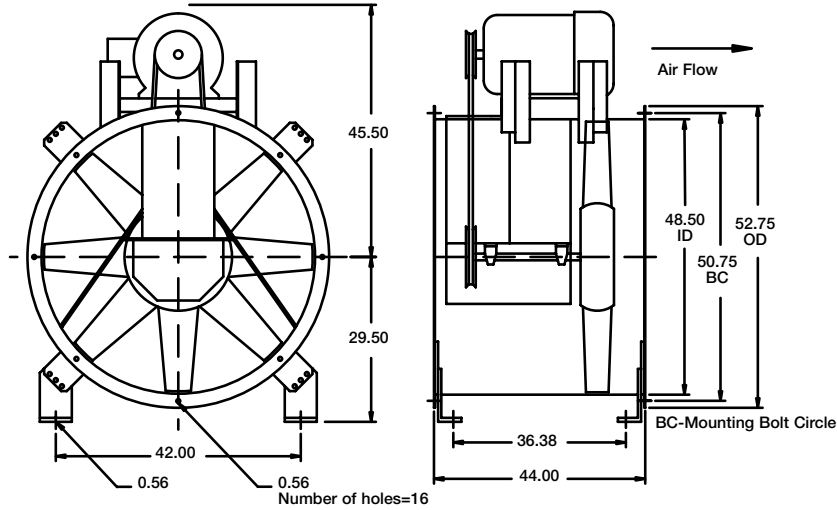

Specifications

- Max Fan RPM - L = 1290
- Max Fan RPM - H = 1347
- Max Motor Frame Size = 324T
- Fan Tube Gauge = 3/16
- Approx. Weight (LM) = 880 lbs.
- Number of Blades = 12

Outlet Velocity (fpm) = CFM / 12.83 ft²
 Tip Speed (fpm) = Fan RPM x 12.57

TBI-CA Performance Data - Level 4

Optimum selection for propeller type shown in bold.

Model Number	Motor HP	Fan RPM	Max BHP	* L _{wi} A	** dBA	Static Pressure in Inches WG / CFM										
						0.000	0.25	0.50	0.75	1.00	1.25	1.50	1.75	2.00	2.25	2.50
						CFM	CFM	CFM	CFM	CFM	CFM	CFM	CFM	CFM	CFM	CFM
4L48-50	5	649	5.01	95	84	31524	28507	24500								
4L48-50	5	672	5.51	98	87	32641	29762	26007								
4H48-50	5	778	5.02	98	87	26958	25085	22841	19804							
4H48-50	5	807	5.50	100	89	27963	26171	24054	21324							
4L48-57	7 1/2	738	7.51	99	88	35847	33257	30113	25946							
4L48-75	7 1/2	764	8.26	100	89	37110	34620	31657	27852							
4H48-75	7 1/2	889	7.51	100	89	30805	29213	27369	25182	22355						
4H48-75	7 1/2	922	8.26	102	91	31948	30422	28683	26634	24139						
4L48-100	10	820	10.01	101	90	39830	37536	34893	31656							
4L48-100	10	838	11.03	102	91	40704	38468	35901	32813	28868						
4H48-100	10	976	10.00	103	91	33819	32378	30772	28952	26763	24004					
4H48-100	10	1012	11.00	103	92	35067	33677	32144	30424	28433	25981					
4L48-150	15	928	15.00	103	92	45076	43097	40871	38316	35331	31583					
4L48-150	15	960	16.50	104	94	46630	44717	42607	40201	37400	34052					
4H48-150	15	1113	15.02	104	93	38567	37303	35954	34485	32853	30964	28700	25814			
4H48-150	15	1153	16.50	104	93	39953	38733	37448	36064	34497	32745	30730	28301			
4L48-200	20	1022	20.00	104	93	49642	47845	45891	43727	41287	38450	35019				
4L48-200	20	1057	22.00	105	94	51342	49604	47731	45676	43380	40763	37712				
4H48-200	20	1228	20.00	104	93	42551	41406	40234	38934	37534	36023	34314	32342	29999		
4H48-200	20	1265	22.00	105	94	43834	42721	41600	40338	39016	37582	35957	34145	32041	29460	
4L48-250	25	1101	25.03	105	94	53479	51811	50033	48107	45980	43583	40829	37601			
4L48-250	25	1139	27.60	106	95	55325	53713	52012	50190	48184	45942	43430	40528			
4H48-250	25	1318	25.00	105	94	45670	44603	43535	42339	41121	39745	38281	36688	34830	32679	30069
4H48-250	25	1347	26.50	105	94	46675	45631	44586	43429	42244	40919	39539	37980	36244	34272	31914
4L48-300	30	1169	30.00	106	95	56782	55211	53568	51823	49870	47740	45371	42684	39572		
4L48-300	30	1209	33.00	106	95	58725	57206	55636	53948	52103	50114	47929	45477	42666		
4L48-400	40	1290	40.00	106	95	62659	61236	59801	58220	56575	54803	52858	50758	48445	45840	

Performance shown is for installation type B: free inlet, ducted outlet. Power rating (Bhp) does not include drive losses. Performance ratings do not include the effects of appurtenances in the airstream.

The sound power level ratings shown are in decibels, referred to 10⁻¹² watts calculated per AMCA Standard 301. Values shown are for inlet L_{wi}A sound power levels for installation type B: free inlet, ducted outlet. Ratings do not include the effects of end correction.

* Sound power values listed are at 0.50 inches pressure wg for each rpm.

** dBA sound pressure values are weighted with 11.5 dB attenuation for each octave band at 5 feet. Listed sound pressure value is for each rpm at 0.50 inches wg.

Shown with optional mounting brackets

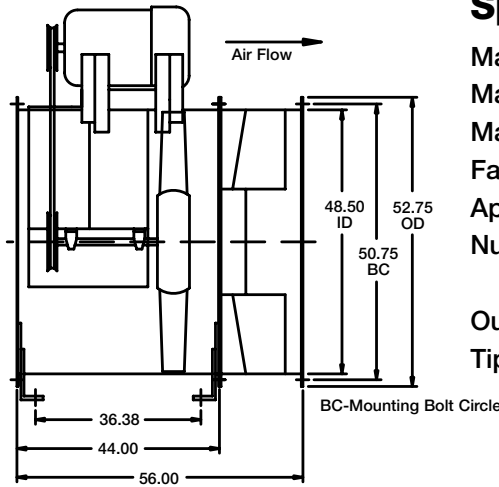
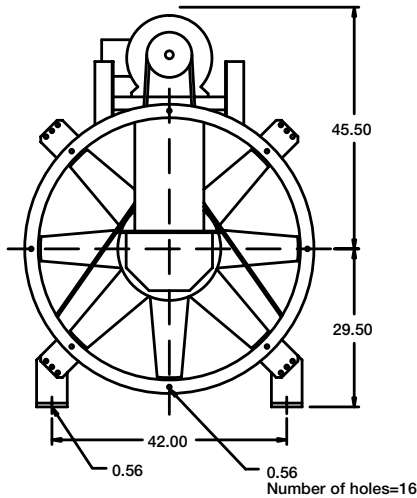

Specifications

- Max Fan RPM - L = 1290
- Max Fan RPM - H = 1347
- Max Motor Frame Size = 324T
- Fan Tube Gauge = 3/16
- Approx. Weight (LM) = 1060 lbs.
- Number of Blades = 12

Outlet Velocity (fpm) = CFM / 12.83 ft²
Tip Speed (fpm) = Fan RPM x 12.57

TBI-CA Performance Data - Level 5

Optimum selection for propeller type shown in bold.

Model Number	Motor HP	Fan RPM	Max BHP	* L _{wi} A	** dBA	Static Pressure in Inches WG / CFM												
						0.50	0.75	1.00	1.25	1.50	1.75	2.00	2.25	2.50	2.75	3.00		
						CFM	CFM	CFM	CFM	CFM	CFM	CFM	CFM	CFM	CFM	CFM		
5L48-50	5	643	5.00	94	83	25378	20703											
5L48-50	5	664	5.50	96	85	26700	22455											
5H48-50	5	770	5.00	97	86	23016	20451	16699										
5H48-50	5	796	5.50	97	86	24086	21723	18516										
5L48-75	7 1/2	736	7.50	98	87	30935	27775	23284										
5L48-75	7 1/2	760	8.26	101	89	32314	29327	25376										
5H48-75	7 1/2	883	7.50	100	89	27514	25625	23312	20220									
5H48-75	7 1/2	912	8.27	101	90	28640	26869	24736	22002	17907								
5L48-100	10	810	10.01	101	90	35124	32499	29243	24786									
5L48-100	10	836	11.02	102	91	36539	34074	31098	27233									
5H48-100	10	972	10.00	102	91	30950	29384	27520	25308	22477								
5H48-100	10	1002	11.03	102	91	32096	30577	28828	26792	24273	20846							
5L48-150	15	928	15.00	102	91	41480	39416	37067	34295	30847								
5L48-150	15	957	16.50	103	92	43020	41069	38854	36302	33224	29190							
5H48-150	15	1112	15.00	103	92	36216	34885	33516	31872	30053	27925	25234	21486					
5H48-150	15	1146	16.50	103	92	37463	36199	34870	33343	31703	29741	27389	24411					
5L48-200	20	1021	20.00	103	92	46396	44594	42600	40400	37883	34853	31003						
5L48-200	20	1053	22.00	104	93	48072	46325	44448	42412	40068	37346	34075						
5H48-200	20	1223	20.00	103	92	40273	39149	37905	36624	35125	33527	31688	29485	26793	23181			
5H48-200	20	1261	22.00	104	93	41653	40594	39387	38180	36767	35313	33573	31670	29436	26563			
5L48-250	25	1099	25.00	104	93	50462	48797	47079	45150	43022	40648	37872	34444					
5L48-250	25	1135	27.50	105	93	52303	50719	49099	47251	45300	43125	40597	37650	34026				
5H48-250	25	1316	25.00	104	93	43644	42666	41518	40361	39116	37722	36256	34547	32628	30428	27654		
5H48-250	25	1345	26.60	104	93	44691	43734	42634	41502	40342	38979	37616	35979	34280	32186	29721		
5L48-300	30	1168	30.06	105	94	53986	52473	50898	49160	47345	45252	42965	40360	37227				
5L48-300	30	1206	33.10	105	94	55918	54483	52957	51341	49583	47671	45625	43215	40480	37208			
5L48-400	40	1285	40.00	105	94	59919	58632	57201	55770	54170	52520	50692	48772	46544	44108	41310		

Performance shown is for installation type B: free inlet, ducted outlet. Power rating (Bhp) does not include drive losses. Performance ratings do not include the effects of appurtenances in the airstream.

The sound power level ratings shown are in decibels, referred to 10⁻¹² watts calculated per AMCA Standard 301. Values shown are for inlet L_{wi}A sound power levels for installation type B: free inlet, ducted outlet. Ratings do not include the effects of end correction.

* Sound power values listed are at 0.50 inches pressure wg for each rpm.

** dBA sound pressure values are weighted with 11.5 dB attenuation for each octave band at 5 feet. Listed sound pressure value is for each rpm at 0.50 inches wg.

TBI-CA Size 54

Belt Drive Level 4



Shown with optional mounting brackets

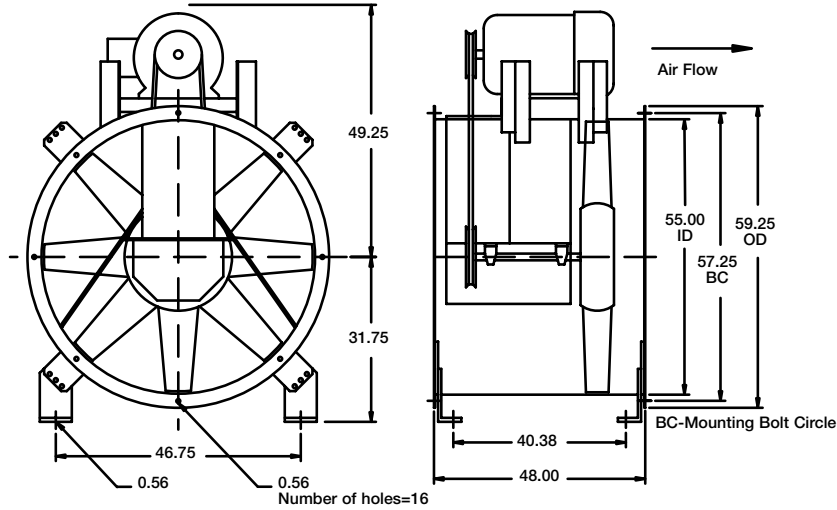

Specifications

- Max Fan RPM - L = 1185
- Max Fan RPM - H = 1185
- Max Motor Frame Size = 326T
- Fan Tube Gauge = 3/16
- Approx. Weight (LM) = 1040 lbs.
- Number of Blades = 12

Outlet Velocity (fpm) = CFM / 16.50 ft²
 Tip Speed (fpm) = Fan RPM x 14.14

TBI-CA Performance Data - Level 4

Optimum selection for propeller type shown in bold.

Model Number	Motor HP	Fan RPM	Max BHP	* L _{wi} A	** dBA	Static Pressure in Inches WG / CFM											
						0.000	0.25	0.50	0.75	1.00	1.25	1.50	1.75	2.00	2.25	2.50	
						CFM	CFM	CFM	CFM	CFM	CFM	CFM	CFM	CFM	CFM	CFM	
4L54-50	5	551	5.02	95	84	37356	32713	25884									
4L54-50	5	569	5.50	95	84	38576	34123	27778									
4H54-50	5	672	5.13	99	88	33130	30265	26524	20790								
4H54-50	5	690	5.51	100	89	34017	31242	27687	22469								
4L54-75	7 1/2	636	7.53	100	89	43118	39213	34240									
4L54-75	7 1/2	658	8.28	102	91	44610	40862	36216									
4H54-75	7 1/2	776	7.89	103	91	38257	35858	32962	29268	24010							
4H54-75	7 1/2	789	8.26	103	92	38898	36550	33725	30193	25226							
4L54-100	10	695	10.03	103	92	47118	43615	39388	33829								
4L54-100	10	718	11.01	103	92	48678	45314	41288	36154								
4H54-100	10	848	10.02	104	93	41806	39658	37145	34098	30253							
4H54-100	10	868	11.04	105	94	42792	40693	38284	35376	31778	26882						
4L54-150	15	795	15.00	106	95	53898	50906	47512	43382	38276							
4L54-150	15	822	16.50	106	95	55728	52835	49585	45788	41036							
4H54-150	15	963	15.00	106	95	47476	45584	43489	41110	38330	34987	30586					
4H54-150	15	997	16.50	106	95	49152	47324	45329	43092	40513	37441	33680					
4L54-200	20	874	20.00	106	95	59254	56533	53538	50126	46109	41223						
4L54-200	20	904	22.10	106	95	61288	58657	55798	52585	48835	44361						
4H54-200	20	1061	20.00	106	95	52307	50590	48767	46773	44464	41839	38769	34968				
4H54-200	20	1098	22.40	107	96	54131	52472	50742	48814	46649	44228	41432	38101	34009			
4L54-250	25	945	25.00	107	96	64067	61551	58866	55908	52502	48477						
4L54-250	25	973	27.50	107	96	65966	63521	60948	58138	54881	51170	46807					
4H54-250	25	1144	25.00	107	96	56399	54806	53184	51334	49338	47156	44641	41729	38277			
4H54-250	25	1178	27.60	108	97	58075	56529	54981	53185	51307	49223	46852	44181	41072	37327		
4L54-300	30	1003	30.10	108	97	67999	65628	63169	60443	57369	53903	49882					
4L54-300	30	1033	33.10	108	97	70033	67731	65379	62733	59833	56602	52886	48656				
4L54-400	40	1101	40.10	109	97	74643	72483	70323	67875	65346	62453	59253	55650	51661			
4L54-400	40	1138	44.00	109	98	77152	75062	72972	70649	68246	65508	62577	59322	55556			
4L54-500	50	1185	50.10	110	99	80474	78470	76467	74299	71995	69509	66825	63800	60489	56834		

Performance shown is for installation type B: free inlet, ducted outlet. Power rating (Bhp) does not include drive losses. Performance ratings do not include the effects of appurtenances in the airstream.

The sound power level ratings shown are in decibels, referred to 10⁻¹² watts calculated per AMCA Standard 301. Values shown are for inlet L_{wi}A sound power levels for installation type B: free inlet, ducted outlet. Ratings do not include the effects of end correction.

* Sound power values listed are at 0.50 inches pressure wg for each rpm.

** dBA sound pressure values are weighted with 11.5 dB attenuation for each octave band at 5 feet. Listed sound pressure value is for each rpm at 0.50 inches wg.

Shown with optional mounting brackets

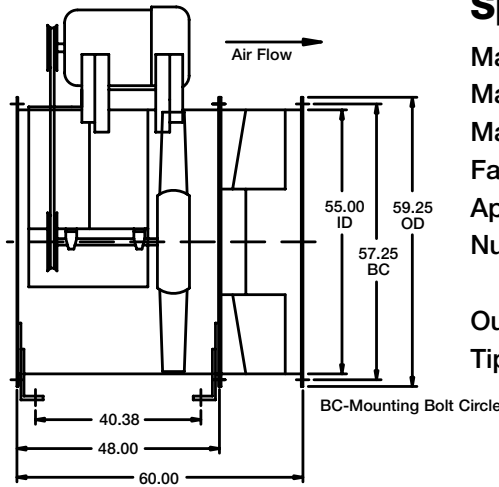
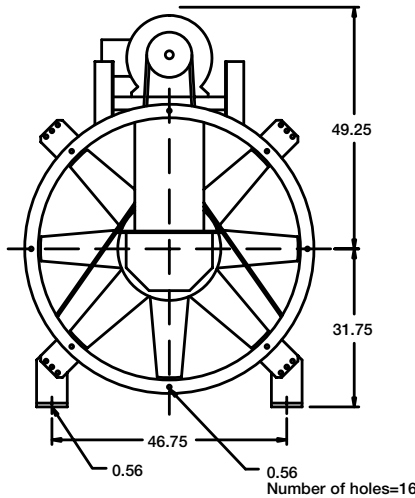

Specifications

- Max Fan RPM - L = 1185
- Max Fan RPM - H = 1185
- Max Motor Frame Size = 326T
- Fan Tube Gauge = 3/16
- Approx. Weight (LM) = 1245 lbs.
- Number of Blades = 12

Outlet Velocity (fpm) = CFM / 16.50 ft²
Tip Speed (fpm) = Fan RPM x 14.14

TBI-CA Performance Data - Level 5

Optimum selection for propeller type shown in bold.

Model Number	Motor HP	Fan RPM	Max BHP	* L _{wi} A	** dBA	Static Pressure in Inches WG / CFM														
						0.50	0.75	1.00	1.25	1.50	1.75	2.00	2.25	2.50	2.75	3.00				
						CFM	CFM	CFM	CFM	CFM	CFM	CFM	CFM	CFM	CFM	CFM				
5L54-50	5	553	5.02	95	84	28232														
5L54-50	5	572	5.52	96	85	30111														
5H54-50	5	670	5.00	98	87	27251	22725													
5H54-50	5	689	5.52	98	87	28438	24327	17615												
5L54-75	7 1/2	631	7.50	103	93	35311	29737													
5L54-75	7 1/2	652	8.27	101	90	37112	32031													
5H54-75	7 1/2	766	7.50	101	89	33025	29907	25588												
5H54-75	7 1/2	788	8.28	101	90	34274	31316	27454	21835											
5L54-100	10	695	10.04	101	90	40616	36333	30337												
5L54-100	10	717	11.00	103	92	42349	38367	32974												
5H54-100	10	841	10.03	104	93	37250	34652	31447	27282	21226										
5H54-100	10	867	11.03	104	93	38696	36262	33309	29510	24374										
5L54-150	15	795	15.00	105	94	48395	45151	41211	36082											
5L54-150	15	821	16.60	105	94	50382	47344	43687	39135											
5H54-150	15	962	15.00	105	94	43911	41801	39445	36718	33363	29037									
5H54-150	15	992	16.50	105	94	45531	43494	41308	38809	35747	32013	27049								
5L54-200	20	875	20.00	105	94	54470	51620	48434	44701	40014										
5L54-200	20	903	22.00	105	94	56562	53811	50852	47472	43292	37974									
5H54-200	20	1058	20.00	105	94	48996	47179	45261	43002	40521	37617	34007	29390							
5H54-200	20	1093	22.00	105	94	50822	49114	47257	45188	42919	40185	37015	33148	28291						
5L54-250	25	942	25.00	106	95	59399	56835	54179	50977	47314	42852									
5L54-250	25	973	27.50	106	95	61643	59220	56657	53692	50407	46488	41606								
5H54-250	25	1140	25.00	106	95	53266	51695	49915	48086	45911	43570	40875	37610	33705	28897					
5H54-250	25	1176	27.50	107	95	55130	53660	51934	50208	48173	46065	43507	40675	37348	33251					
5L54-300	30	1001	30.00	107	95	63662	61361	58870	56116	53103	49441	45094								
5L54-300	30	1034	33.00	107	96	66034	63868	61457	58943	56027	52760	48979	44390							
5L54-400	40	1102	40.00	108	97	70895	68987	66728	64465	61942	59205	56064	52564	48367						
5L54-400	40	1138	44.00	108	97	73456	71608	69490	67299	65021	62371	59633	56362	52646	48399					
5L54-500	50	1185	50.00	108	97	76931	75159	73221	71121	69020	66621	64081	61272	58136	54444	50340				

Performance shown is for installation type B: free inlet, ducted outlet. Power rating (Bhp) does not include drive losses. Performance ratings do not include the effects of appurtenances in the airstream.

The sound power level ratings shown are in decibels, referred to 10⁻¹² watts calculated per AMCA Standard 301. Values shown are for inlet L_{wi}A sound power levels for installation type B: free inlet, ducted outlet. Ratings do not include the effects of end correction.

* Sound power values listed are at 0.50 inches pressure wg for each rpm.

** dBA sound pressure values are weighted with 11.5 dB attenuation for each octave band at 5 feet. Listed sound pressure value is for each rpm at 0.50 inches wg.

TBI-CA Size 60

Belt Drive Level 4



Shown with optional mounting brackets

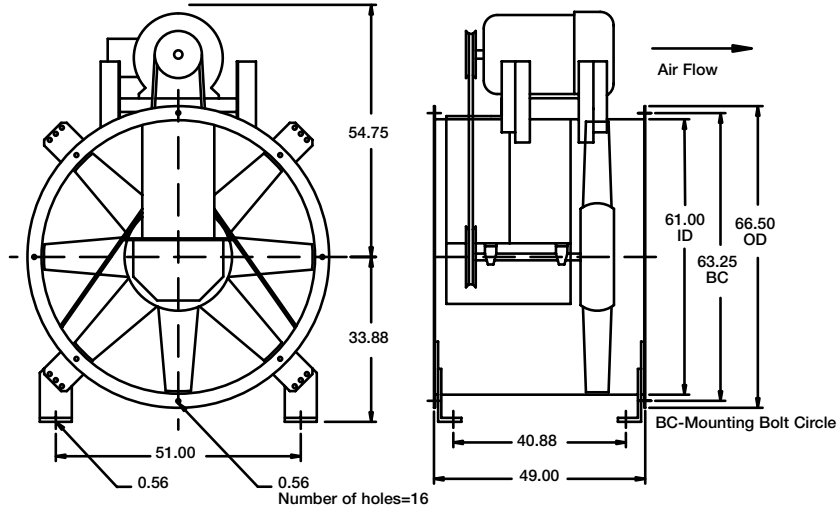

Specifications

- Max Fan RPM - L = 1071
- Max Fan RPM - H = 1071
- Max Motor Frame Size = 364T
- Fan Tube Gauge = 1/4
- Approx. Weight (LM) = 1430 lbs.
- Number of Blades = 14

Outlet Velocity (fpm) = CFM / 20.30 ft²
 Tip Speed (fpm) = Fan RPM x 15.71

TBI-CA Performance Data - Level 4

Optimum selection for propeller type shown in bold.

Model Number	Motor HP	Fan RPM	Max BHP	* L _{wi} A	** dBA	Static Pressure in Inches WG / CFM										
						0.000	0.25	0.50	0.75	1.00	1.25	1.50	1.75	2.00	2.25	2.50
						CFM	CFM	CFM	CFM	CFM	CFM	CFM	CFM	CFM	CFM	CFM
4L60-75	7 1/2	536	7.54	93	82	48063	42921	35576								
4L60-75	7 1/2	554	8.29	95	84	49677	44729	37919								
4H60-75	7 1/2	642	7.50	98	87	41958	38786	34629	29081							
4H60-75	7 1/2	667	8.28	99	88	43592	40562	36677	31575							
4L60-100	10	592	10.01	98	87	53085	48509	42633								
4L60-100	10	613	11.05	99	88	54968	50580	45091								
4H60-100	10	718	10.02	100	89	46925	44155	40777	36421							
4H60-100	10	742	11.58	101	90	48493	45835	42613	38565	33649						
4L60-150	15	676	15.01	102	91	60617	56728	52081	46117							
4L60-150	15	698	16.50	102	91	62590	58856	54423	48939							
4H60-150	15	821	15.00	103	92	53656	51321	48559	45253	41304						
4H60-150	15	836	16.50	104	93	54637	52343	49673	46469	42693	38266					
4L60-200	20	742	20.00	104	93	66535	63056	59051	54203	48125						
4L60-200	20	767	22.00	104	93	68777	65411	61603	57106	51488						
4H60-200	20	901	20.00	104	93	58885	56756	54359	51598	48383	44595					
4H60-200	20	921	22.00	104	93	60192	58110	55782	53120	50048	46468	42440				
4L60-250	25	802	25.10	104	93	71915	68696	65106	61001	56003						
4L60-250	25	825	27.60	104	93	73978	70849	67392	63473	58848	53176					
4H60-250	25	968	25.00	105	93	63264	61282	59110	56668	53873	50673	47056				
4H60-250	25	992	27.50	105	94	64832	62899	60801	58464	55804	52766	49322	45560			
4L60-300	30	850	30.00	105	94	76220	73182	69865	66138	61794	56582					
4L60-300	30	879	33.10	105	94	78820	75883	72718	69203	65171	60348					
4H60-300	30	1026	30.10	105	94	67054	65185	63188	60994	58480	55651	52476	48936			
4H60-300	30	1053	33.00	105	94	68819	66998	65076	62962	60541	57860	54861	51531	47954		
4L60-400	40	936	40.00	105	95	83931	81173	78284	75108	71507	67404	62619				
4L60-400	40	964	44.00	106	95	86442	83764	81000	77917	74507	70685	66250	61240			
4L60-500	50	1008	50.00	106	95	90387	87826	85248	82299	79173	75772	71787	67245			
4L60-500	50	1039	55.00	107	96	93167	90682	88198	85366	82429	79142	75444	71270	66636		
4L60-600	60	1071	60.10	107	96	96037	93626	91216	88516	85741	82577	79175	75365	71016		

Performance shown is for installation type B: free inlet, ducted outlet. Power rating (Bhp) does not include drive losses. Performance ratings do not include the effects of appurtenances in the airstream.

The sound power level ratings shown are in decibels, referred to 10⁻¹² watts calculated per AMCA Standard 301. Values shown are for inlet L_{wi}A sound power levels for installation type B: free inlet, ducted outlet. Ratings do not include the effects of end correction.

* Sound power values listed are at 0.50 inches pressure wg for each rpm.

** dBA sound pressure values are weighted with 11.5 dB attenuation for each octave band at 5 feet. Listed sound pressure value is for each rpm at 0.50 inches wg.

Shown with optional mounting brackets

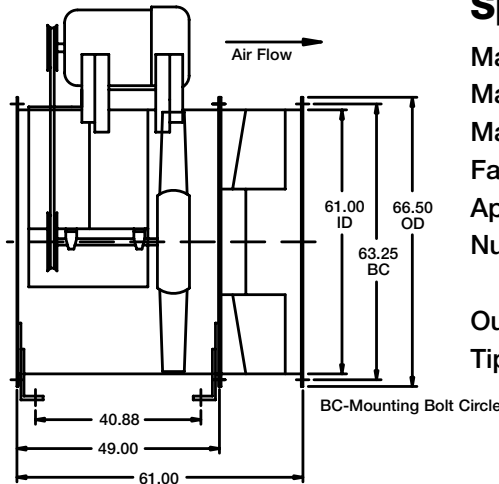
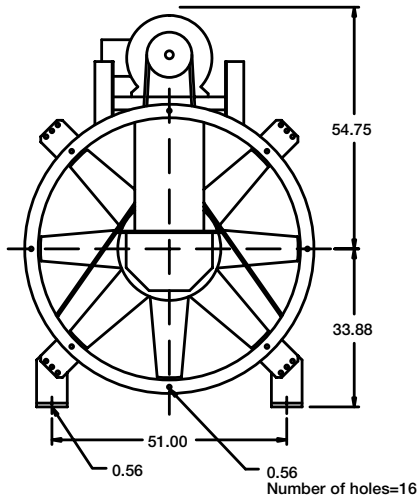

Specifications

- Max Fan RPM - L = 1071
- Max Fan RPM - H = 1071
- Max Motor Frame Size = 364T
- Fan Tube Gauge = 1/4
- Approx. Weight (LM) = 1685 lbs.
- Number of Blades = 14

Outlet Velocity (fpm) = CFM / 20.30 ft²
Tip Speed (fpm) = Fan RPM x 15.71

TBI-CA Performance Data - Level 5

Optimum selection for propeller type shown in bold.

Model Number	Motor HP	Fan RPM	Max BHP	* L _{wi} A	** dBA	Static Pressure in Inches WG / CFM														
						0.50	0.75	1.00	1.25	1.50	1.75	2.00	2.25	2.50	2.75	3.00				
						CFM	CFM	CFM	CFM	CFM	CFM	CFM	CFM	CFM	CFM	CFM				
5L60-75	7 1/2	537	7.54	95	84	38032														
5L60-75	7 1/2	553	8.29	95	84	39994	31768													
5H60-75	7 1/2	648	7.51	98	87	36054	31476													
5H60-75	7 1/2	657	8.25	98	87	36765	32330	26974												
5L60-100	10	589	10.01	98	87	44061	37476													
5L60-100	10	608	11.05	99	87	46174	40220													
5H60-100	10	708	10.01	98	87	40744	36991	32341												
5H60-100	10	734	11.54	101	90	42743	39229	34967	30098											
5L60-150	15	674	15.01	102	91	53212	48601	42379												
5L60-150	15	696	16.50	102	91	55461	51110	45573												
5H60-150	15	804	15.20	102	91	47879	44976	41536	37421	32965										
5H60-150	15	831	16.50	103	91	49831	47095	43877	40105	35855										
5L60-200	20	742	20.00	103	92	60115	56258	51601	45681											
5L60-200	20	766	22.00	103	92	62520	58903	54602	49196											
5H60-200	20	884	20.00	103	92	53633	51202	48389	45093	41322	37282									
5H60-200	20	918	22.00	103	92	56054	53772	51114	48099	44665	40876									
5L60-250	25	800	25.00	103	92	65904	62547	58601	53936	47954										
5L60-250	25	825	27.50	103	92	68377	65122	61419	57114	51834										
5H60-250	25	954	25.00	103	92	58603	56407	53946	51191	48058	44549	40812								
5H60-250	25	984	27.80	104	93	60718	58589	56284	53735	50811	47524	43968	40298							
5L60-300	30	850	30.10	104	93	70838	67678	64209	60249	55466	49422									
5L60-300	30	877	33.10	104	93	73459	70421	67192	63536	59167	53911									
5H60-300	30	1014	30.00	104	93	62810	60759	58603	56168	53414	50368	47032	43514							
5H60-300	30	1043	33.10	104	93	64802	62846	60828	58461	55902	53079	49947	46564	43102						
5L60-400	40	935	40.10	105	93	78981	76256	73383	70081	66481	62332	57249								
5L60-400	40	965	44.00	105	94	81823	79247	76464	73413	70090	66167	61659	56240							
5L60-500	50	1007	50.20	105	94	85785	83408	80741	78024	74840	71445	67593	62982	57551						
5L60-600	50	1040	55.20	106	95	88887	86657	84075	81492	78525	75442	71796	67783	63113						
5L60-600	60	1070	60.00	106	95	91700	89576	87087	84577	81842	78845	75564	71939	67639	62709					

Performance shown is for installation type B: free inlet, ducted outlet. Power rating (Bhp) does not include drive losses. Performance ratings do not include the effects of appurtenances in the airstream.

The sound power level ratings shown are in decibels, referred to 10⁻¹² watts calculated per AMCA Standard 301. Values shown are for inlet L_{wi}A sound power levels for installation type B: free inlet, ducted outlet. Ratings do not include the effects of end correction.

* Sound power values listed are at 0.50 inches pressure wg for each rpm.

** dBA sound pressure values are weighted with 11.5 dB attenuation for each octave band at 5 feet. Listed sound pressure value is for each rpm at 0.50 inches wg.

Tube Axial Specification - TBI-CA / TDI Level 4 and 5

Inline fans shall be of the axial type with cast aluminum airfoil propellers.

The housing shall be constructed of continuously welded steel and include integral punched inlet and outlet flanges to prevent air leakage. The housing, bearing support and motor base shall be constructed of structural members to prevent vibration and rigidly support the shaft, bearings, and motor.

Blades shall be airfoil design. Hub and blades shall be heat treated cast aluminum alloy A365-T6 with hub blade bases and sockets precision machined. Propeller hub is a single piece casting with a minimum of eight blades. Rotor blade pitch shall be manually adjustable within horsepower limitations. Rotors to be statically and dynamically balanced. A standard square key or tapered bushing shall lock the rotor to the fan shaft. Blades shall be attached to the hub with steel studs.

Steel housings and structural components to be coated with Permator, an electrostatically applied thermosetting polyester urethane. Minimum coating thickness to be 2 mils.

Fan performance shall be based on tests conducted in accordance with AMCA Standard 210.

Fan shall be model TDI / TBI-CA as manufactured by Greenheck's of Schofield, Wisconsin.

Additional Belt Drive Specification

Bearings shall be cast iron pillow block, grease lubricated and self-aligning. Bearings shall be Air Handling Quality and tested for reduced swivel torque, bore size, noise, and vibration. Bearings shall be selected for an L(10) life, per ABMA standards, in excess of 80,000 hours for horizontal applications or L(10) life of 40,000 hours for vertical applications.

Turned, precision ground and polished steel shafts shall be sized so the first critical speed is at least 25% over the maximum operating speed for each level of construction.

Additional Level 5 Specification

Bolt-on straightening vane section to be fastened to outlet flange. Vanes shall be welded to inner diameter of bolt-on section. Minimum of seven blades constructed of at least 10 ga material to be used.

Warranty

Greenheck's warrants this equipment to be free from defects in material and workmanship for a period of one year from the purchase date. Any units or parts which prove defective during the warranty period will be replaced at our option when returned to our factory, transportation prepaid.

Motors are warranted by the motor manufacturer for a period of one year. Should motors furnished by Greenheck's prove defective during this period, they should be returned to the nearest authorized motor service station. Greenheck's will not be responsible for any removal or installation costs.

Due to continuing research, Greenheck's reserves the right to change specifications without notice.



Number one in air movement and control.



Centrifugal and Vane Axial Fans



Fans and Ventilators



Energy Recovery Ventilators & Make-Up Air Units



Kitchen Ventilation Systems



Dampers and Louvers

Visit the Greenheck's website for the most current information available

www.greenheck's.com

Greenheck's • P.O. Box 410 Schofield, WI 54476-0410 • Phone (715)359-6171 • Fax (715)355-2399 •

www.greenheck's.com