



TBI *Tubular Belt Inline Fan*
TDI *Tubular Direct Inline Fan*

Installation Operation and Maintenance Manual

READ AND SAVE THESE INSTRUCTIONS



TBI-CA, TBI-FS
Level 3, 4 & 5



TDI
Level 3, 4 & 5

RECEIVING

Greenheck model TBI / TDI fans are thoroughly inspected and test run at the factory. Items such as proper propeller alignment, balance, and workmanship are analyzed by personnel using state-of-the-art equipment. However, damage may occur during handling and shipping. Therefore, it is important that the unit be carefully inspected for visible and concealed damage before beginning installation. In addition, check to see that all accessory items are accounted for.

Report any damaged equipment to the shipper immediately!

HANDLING

Fans should **NOT** be lifted by the shaft, housing, motor, belt guard, or any accessories.

Units - Flanged Housing Only

Use a minimum of four bolt holes, two per flange, or attach two suitable chains / straps around the entire fan housing, one near each duct flange, when lifting large horizontal fans. Secure the fan housing to prevent the weight of a top or side mounted motor from rotating the housing while being lifted.

For vertical hanging installations, attach a suitable lifting device to the fan housing or inlet/outlet flange.

Units - With Mounting Brackets

Fans are to be rigged by either the optional brackets provided or by the skid when a forklift is used. Slings can be attached as described above or to mounting brackets located at the ends of the fan housing (Fig. 1).

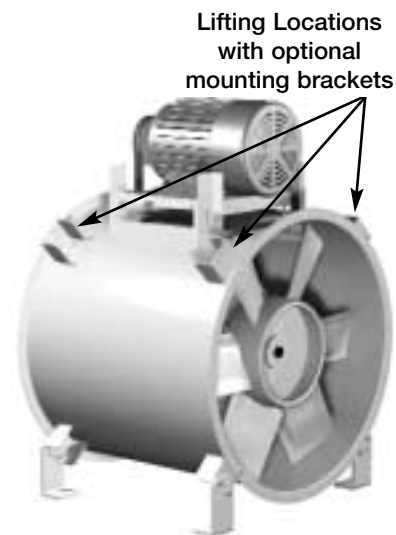

Fig. 1

STORAGE - Indoor and Outdoor

When a fan is to be stored for a period of time, it must be protected from dirt and moisture. Use of a tarp to cover the unit will aid in keeping it clean and dry, but avoid using a black plastic tarp as it will promote condensation. Improper storage which results in damage to the fan will void the warranty. If the storage period is lengthy, the propeller and motor should be rotated periodically and the bearings purged with fresh grease. In humid, dusty, or corrosive atmospheres, rotate the fan and purge the bearings once a month. Under normal conditions, this procedure should be repeated once every three months.

INSTALLATION

EFFECT OF INSTALLATION ON PERFORMANCE

Any installation with inlet or discharge configurations that deviate from these recommendations may result in reduced fan performance. Restricted or unstable flow at the fan inlet can cause pre-rotation of incoming air or uneven loading of the fan prop yielding large system losses and increased sound levels. Free discharge or turbulent flow in the discharge ductwork will also result in system effect losses.

The most common inlet and discharge conditions which affect fan performance are:

INLET DUCT TURNS

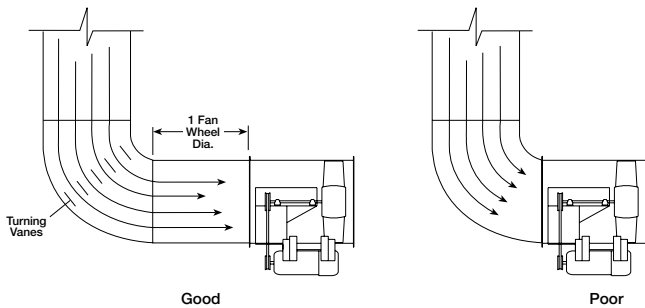

DISCHARGE DUCT TURNS

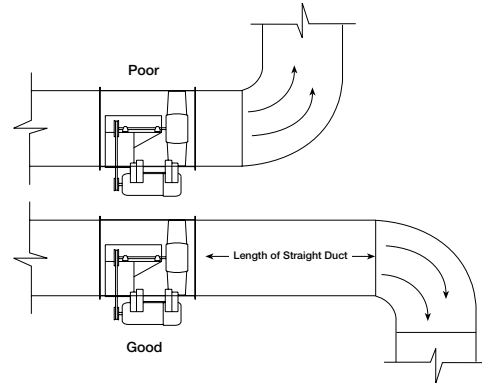

Installation of a duct turn or elbow too close to the fan inlet reduces fan performance because air is loaded unevenly into the fan prop. To achieve full fan performance there should be at least one to two fan prop diameters between the turn or elbow and the fan inlet.

Fan performance is reduced when duct turns are made immediately off the fan discharge. To achieve cataloged fan performance, there should be at least one equivalent duct diameter of straight ductwork between the fan discharge and any duct turns.

TYPICAL INSTALLATIONS - WITH MOUNTING BRACKETS

Following are typical mounting installations for models with mounting brackets. Diagrams show dimensions for ceiling hung installations, the dimensions for floor or base mount installations are mirror images of these. For TBI's with motor in the 3 or 9 o'clock position or vertical installations, additional mounting rails are recommended. Mounting rail dimensions are shown for field fabrication.

Horizontal

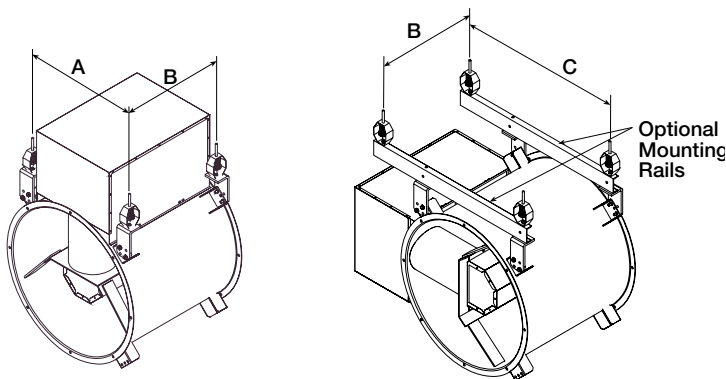

Vertical

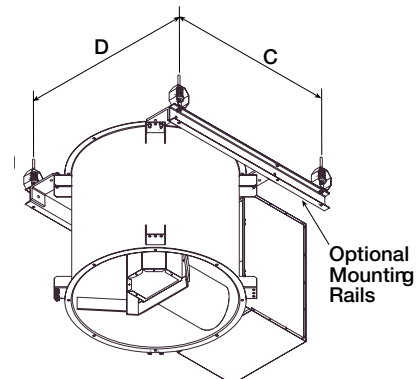

Motor at 3 or 9 o'clock position

Mounting Hole Locations

Unit Level Identification - Refer to fan name plate

Example: TBI-3L42 (level 3)
TBI-4H30 (level 4)

TBI/TDI Fan Size	A		B				C Belt Drive	D Belt Drive
	Belt Drive	Direct Drive	Belt Drive		Direct Drive			
			Level 3	Level 4/5	Level 3	Level 4/5		
18	17.63	17.63	17.38	21.38	13.38	21.38	26.00	28.00
20	19.00	19.00	17.38	22.38	14.38	21.38	28.50	29.25
24	21.88	21.88	18.38	23.38	14.38	21.38	33.00	33.75
30	26.13	26.13	19.38	28.38	16.38	25.88	37.00	38.75
36	30.50	30.50	21.88	26.88	13.88	23.38	44.00	47.00
42	34.75	34.75	22.88	31.88	19.88	26.38	50.00	51.25
48	42.00	42.00	25.38	36.38	19.38	31.38	56.00	61.00
54	46.75	46.75	29.88	40.38	NA	31.38	62.00	65.50
60	51.00	51.00	32.38	41.38	NA	31.38	71.00	70.00



MODEL

S/N

MARK

TYPICAL HIGH TEMPERATURE CONTINUOUS DUTY INSTALLATIONS

TBI-FS with optional high temperature construction are factory modified for operation in high temperature continuous duty applications. With propeller on the discharge end of the fan, negative pressure is created in the belt tube during operation. Ambient air is drawn in through the belt tube and cools the belts and bearings.

For the greatest amount of internal cooling, discharge static pressure should be kept to a minimum while keeping most of the pressure on the inlet side. Locate the fan at ends of the duct runs and near the discharge point in the system. This set-up will promote the ambient air cooling effect.

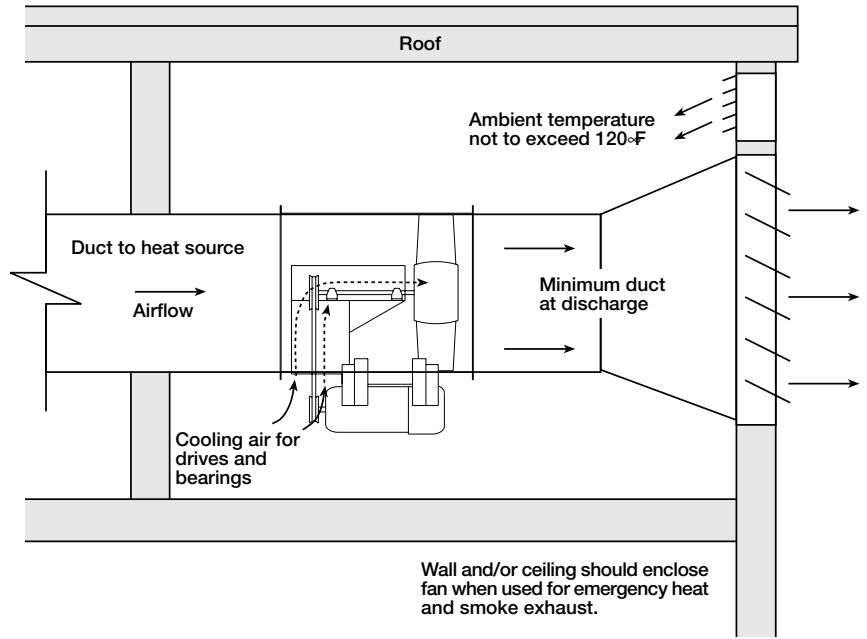

OPERATION

ELECTRICAL CONNECTIONS

Before electrical connections are made, the supply voltage, phase and ampere capacity must be checked for compatibility with the fan motor. In addition, the supply wiring must be properly fused and conform to local and national electrical codes.

The supply wires are then connected to an **optional** safety disconnect switch (if supplied) or wired directly to the motor.

PRE-START UP CHECKS

1. Check all fasteners for tightness. This includes motor bolts, bearing bolts, and any set screws or locking collars attaching the propeller to the shaft and shaft to the bearings.
2. Prop rotation should be in the same direction as the rotation decal affixed to the unit. For 3-phase installations, fan rotation can be reversed by simply interchanging any two of the three electrical leads. For single phase installations, follow the wiring diagram located on the motor.
3. (*Belt Drive*) Adjustable motor pulleys are preset at the factory for the specified fan RPM. Fan speed can be increased by closing or decreased by opening the adjustable pulley. Two or three groove variable pitch pulleys must be adjusted an equal number of turns open or closed.

Note: Any change, increase or decrease, in fan speed can represent a substantial increase in horsepower required from the motor. Always check motor load amperage and compare to name plate rating when changing fan speed.

MAINTENANCE

WARNING

Disconnect and secure to the "OFF" position all electrical power to the fan prior to inspection or servicing. Failure to comply with this safety precaution could result in serious injury or death.

Once the fan has been put into operation, a periodic maintenance program should be set up to preserve the reliability and performance of the fan. Items to be included in this program are:

- BEARINGS
- LUBRICATION
- SET SCREWS
- FASTENERS
- BELTS
- REMOVAL OF DUST/DIRT

BEARINGS (*Belt Drive*)

Bearings are the most critical moving part of the fan and should be inspected at periodic intervals. Locking collars and set screws, in addition to fasteners attaching the bearing to the bearing plate, must be checked for tightness. In a clean environment and temperature above 32° F (0° C) and below 200° F (93° C), fan shaft bearings with grease fittings should be lubricated semi-annually using a high quality lithium based grease. If unusual environmental conditions exist such as temperatures below 32° F (0° C) and above 200° F (93° C), moisture or contaminants, more frequent lubrication is required.

With the unit running, add grease very slowly with a manual grease gun. Be careful not to unseat the seal by over lubricating or using excessive pressure. Bearings without grease fittings are lubricated for life.

BELTS (Belt Drive)

Premature belt failures are frequently caused by improper belt tension (either too tight or too loose) or misaligned pulleys. The proper tension for operating a V-belt is the lowest tension at which the belts will not slip at peak load conditions. For initial tensioning, the proper belt deflection half-way between pulley centers is 1/64" for each inch of belt span. For example, if the belt span is 64 inches, the belt deflection should be one inch using moderate thumb pressure at midpoint of the drive (Fig. 2).

Check belt tension two times during the first 24 hours of operation and periodically thereafter. To adjust belt tension, simply pivot the motor on the motor plate. Use the bolts in the slotted brackets and adjustment rods with bolts as adjustment points until proper belt tension is attained.

It is very important that the drive pulleys remain in proper alignment after adjustments are made. Misalignment of pulleys will result in premature belt wear, noise, vibration and power loss (Fig. 3).

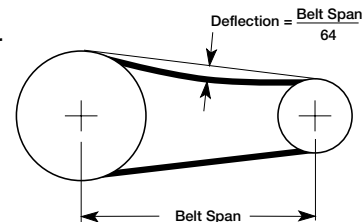

Fig. 2

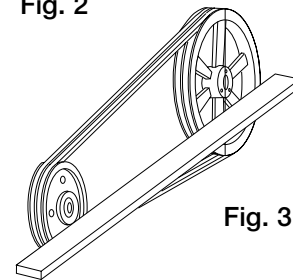

Fig. 3

FASTENERS AND SET SCREWS (Belt & Direct Drive)

A periodic inspection should include checking all fasteners and set screws for tightness. Particular attention should be paid to set screws and locking collars attaching the propeller to the shaft and the shaft to the bearings. Loose bearing set screws and locking collars will lead to premature failure of the fan shaft.

MOTOR LUBRICATION (Belt & Direct Drive)

Refer to the paragraph on bearings for bearing lubrication. Many fractional horsepower motors installed on the smaller fans are lubricated for life and require no further attention. Greasing of motors is intended only when fittings are provided. Motors equipped with oil holes should be oiled in accordance with the manufacturer's instructions printed on the motor. Use a high grade SAE 20 machine oil and use caution not to over lubricate. Motors supplied with grease fittings should be greased according to directions printed on the motor.

REMOVAL OF DUST AND DIRT (Belt & Direct Drive)

Dirt clogs cooling openings on the motor housing, contaminates bearing lubricant, and collects on the impeller causing severe imbalance if left unchecked. The exterior surface of the motor and impeller should be thoroughly cleaned periodically. Use caution and do not allow water or solvents to enter the motor or bearings. Under no circumstances should motors or bearings be sprayed with steam or water.

PARTS LIST

Each fan bears a manufacturer's nameplate with model number and serial number embossed. This information in addition to the shown parts diagram will assist the local Greenheck representative and the factory in providing service and replacement parts.

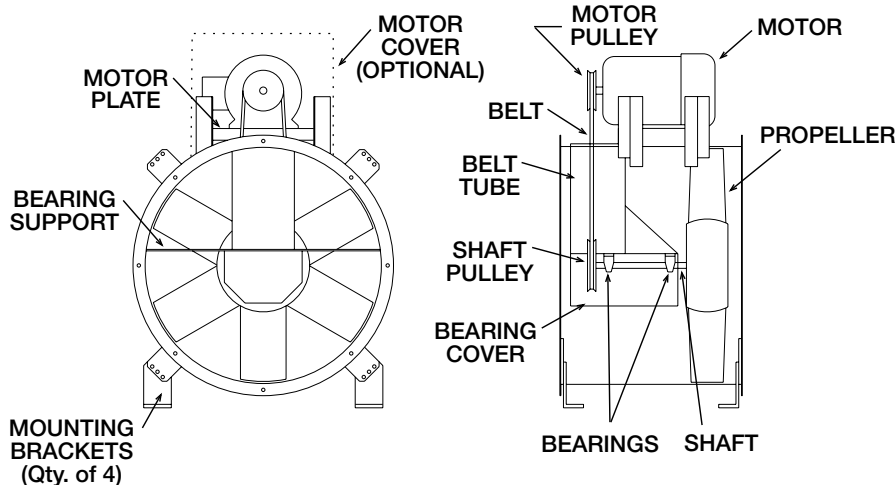

Warranty

Greenheck warrants this equipment to be free from defects in material and workmanship for a period of one year from the purchase date. Any units or parts which prove defective during the warranty period will be replaced at our option when returned to our factory, transportation prepaid.

Motors are warranted by the motor manufacturer for a period of one year. Should motors furnished by Greenheck prove defective during this period, they should be returned to the nearest authorized motor service station. Greenheck will not be responsible for any removal or installation costs.