

# READ AND SAVE THESE INSTRUCTIONS

P.N. XXXXXX



## Tube Axial Upblast Fans

Model TAUD (Direct Drive, Aluminum Propeller)

Model TAUB-CA (Belt Drive, Aluminum Propeller)

Model TAUB-L/H (Belt Drive, Steel Propeller, High Temp.)

## INSTALLATION, OPERATION AND MAINTENANCE MANUAL

Greenheck Model TAUD, TAUB-CA and TAUB-L/H fans are thoroughly inspected and test run at the factory, however damage may occur during handling and shipping. Consequently, it is important that the unit be carefully inspected for visible and concealed damage before beginning installation. Report any damage to the shipper immediately. In addition, assure all accessory items are accounted for.

### INSTALLATION

#### LIFTING

Attach a suitable chain or strap to the four points depicted in Fig. 1. The fan should never be lifted by the motor, belt tube, damper frame, windband or accessories.

Carefully lift the fan to the roof curb and install fasteners in all holes provided in the unit base. The windband need not be removed for the lifting operation.

#### ELECTRICAL CONNECTIONS

The electrical supply must be compatible with the fan motor with voltage, phase and amperage capacity. The electrical supply line must be properly fused and conform to local and national electrical codes.

For direct drive units, the electrical supply may be routed internally and exit through a hole provided in the fan housing if an optional service disconnect switch is provided.

For belt drive units, the electrical supply line may be routed internally and exit the fan housing through a hole provided below the belt tube opening (Fig. 1). The electrical supply line should then be either: (1) connected to an optional service disconnect switch, or (2) wired directly to the motor.

For belt drive units in Continuous High Temperature installations, the electrical supply must be kept out of the air stream. This means bringing the supply lines off the roof deck not through the fan. The electrical supply line should then be either: (1) connected to an optional service disconnect switch, or (2) wired directly to the motor.

For belt drive units in Emergency Smoke Removal installations, the electrical supply must be kept out of the airstream. They may also require an isolated power supply so that if power is cut to the building in the event of a fire, the fan will continue to operate. Check the local and national electrical codes for emergency smoke removal fans.

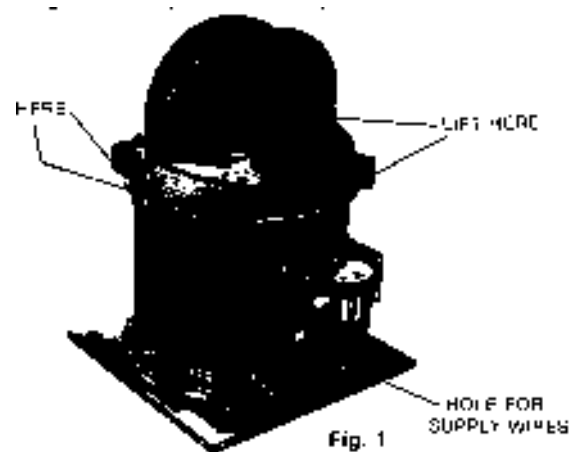

### \*\* WARNING \*\*

Disconnect and secure to the "off" position all electrical power to the fan prior to inspection or service.

Caution must be used when working around the fusible link damper lifters. They may release the dampers unexpectedly.

Models TAUD and TAUB-CA may have fusible link damper lifters and all models TAUB L/H with HT- options 2, 3 and 4 have fusible link damper lifters under spring tension. TAUB fans UL listed as "Power ventilators for smoke control systems" in sizes 42, 48, 54 and 60 have extra heavy duty fusible link damper lifters under high spring tension that, for safety reasons, must be pinned to prevent accidental release. See (fig. 2) on page 2 for details on how to secure the lifter arms.



**FAILURE TO COMPLY WITH THESE SAFETY PRECAUTIONS MAY  
RESULT IN SERIOUS INJURY OR DEATH!**

**WARNING!**

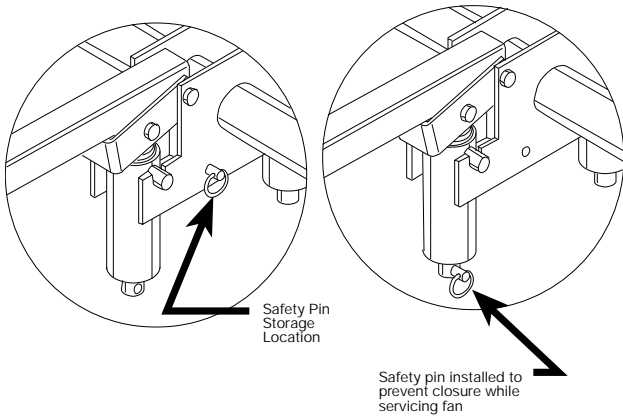
These fans have extra heavy duty fusible link damper lifters under very high spring tension that must be pinned so they can not be accidentally tripped when servicing the fan. The fusible link damper lifters are located under the butterfly damper blades. Fig. A, shows where the safety pin MUST be placed when the fan is being serviced. Fig. B, shows where the safety pin is placed for storage when the fan is in service. Fan sizes 24, 30 and 36 also have fusible link damper lifters, but they do not have the ability to be pinned when servicing due to differences in lifter designs. In either case, extreme care must be taken when working around the damper lifter assemblies or serious bodily injury or death may result.



Models TAUB-L/H with HT-Option 4 will bear the label shown above in Fig. C. For fan sizes 42, 48, 54 and 60 with HT-Option 4, Figs. A and B Apply.

 LR-34470	- IMPORTANT - <b>Electrical</b> - This equipment must be installed with remote overload protection having adequate rating as to voltage, frequency, horsepower and full load current per phase. Where connected to a circuit protected by fuses, use time delay fuses. For supply connection use wires rated for at least 90°C (194°F)	 LISTED POWER VENTILATOR FOR SMOKE CONTROL SYSTEMS. 76Y9
	<b>Installation</b> - When connecting electrical power to this fan, do not restrict motor movement. Motor must have sufficient movement for possible future belt or wheel adjustment.	

**PRESTARTING CHECKS**

**FASTENERS** - Check all fasteners and set screws for tightness. This is especially important for bearings and propellers. Rotate the propeller by hand to assure it turns freely and does not rub on the fan tube. Also, lift the butterfly dampers to check if they open and close without binding. **CAUTION: See **\*\*WARNING\*\*** on page 1.**

**PROPELLER ROTATION** - Direction of propeller rotation should be checked by turning the unit on momentarily. Rotation should be in the same direction shown on the rotation decal affixed to the unit or as shown in Fig. 3. To reverse rotation on three phase installations, simply interchange two of the three electrical leads. For single phase installations, follow the wiring diagram located on the motor nameplate.

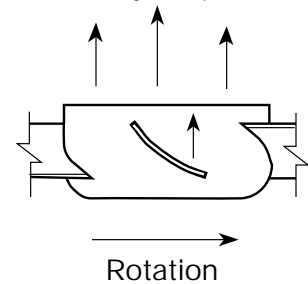

**FAN RPM** - For belt drive units, the adjustable motor pulley is preset at the factory to the customer specified RPM. Fan speed can be increased or decreased by the adjusting the pitch diameter of the motor pulley. Multi-groove variable pitch pulleys must be adjusted an equal number of turns open. Always check the motor amperage reading and compare it to the amperage rating shown on the motor nameplate when changing fan RPM.

**ROUTINE MAINTENANCE FOR BELT DRIVE FANS**

**CAUTION:** See **\*\*WARNING\*\*** on page 1.

Once the fan has been put into operation, periodic maintenance should be scheduled to assure reliability and performance. The following items should be checked as a part of this maintenance schedule:

- 1. Fasteners and set screws
- 2. Bearings
- 3. Lubrication
- 4. Belts
- 5. Removal of dust and dirt

**1. FASTENERS AND SET SCREWS** - Normal fan vibration has a tendency to loosen mechanical fasteners. Periodic inspection should include checking all fasteners and set screws, including the propeller fasteners, for tightness.

**2. BEARINGS** - The pillow block ball bearings installed on Model TAUB-CA and TAUB-L/H fans are air handling quality, grease lubricated, self aligning, and selected for a minimum L-50 life in excess of 200,000 hours. However, bearings are one of the most critical parts of a fan and should be inspected at regular intervals. Locking collars, set screws and fasteners attaching the bearings to the fan should also be checked.

**3. LUBRICATION** - Bearings operating in a clean environment and temperatures between 32°F and 200°F should be lubricated semiannually using a high quality lithium based grease. Bearings operating outside these temperature parameters require special high or low temperature grease. If contamination or high moisture conditions exist, more frequent lubrication is required.

Model TAUB-CA and TAUB-L/H fans are equipped with extended lubrication lines as standard. The grease fittings are located on the exterior of the fan housing next to the motor weather cover and should be wiped clean before adding grease.

When adding grease to the fan bearings, rotate the fan shaft while slowly operating the manual grease gun. Be careful not to unseat the bearing seals by over lubricating or using excessive pressure. Stop pumping when a very slight resistance is felt at the grease gun.

Lubrication of motors is intended only when fittings are provided. Many fractional horsepower motors are permanently lubricated for life and require no further lubrication. Motors supplied with grease fittings should be greased in accordance with the manufactures directions on the motor nameplate.

**4. BELTS** - Premature belt failures are frequently caused by improper belt tension (either too loose or too tight), misaligned pulleys or by prying belts on and off pulleys. The proper tension for operating a V-belt is the lowest tension at which the belts will not slip at peak load conditions. For initial tensioning, the proper belt deflection is 1/64" for each inch of belt span, measured half way between the pulley centers.

For Example:

A belt span of 32 inches should have a 32/64 or 1/2 inch of deflection using moderate thumb pressure at the midpoint of the drive. See Fig 4.

Check belt tension after the first 24 hours of operation, after 100 hours of operation and periodically thereafter. Belt tension can be adjusted by loosening the motor plate hinge bolts and adjusting the jack screws as required.

When replacing belts, always use the same size and type as originally supplied by the factory. Check pulleys for wear and replace both pulleys and belts if wear is evident. NOTE: Model TAUB-L/H requires high temperature belts. It is very important that the drive pulleys remain in proper alignment after adjustments are made. Misalignment of pulleys will result in premature belt and bearing failure, noise, and loss of fan efficiency. See Fig 5.

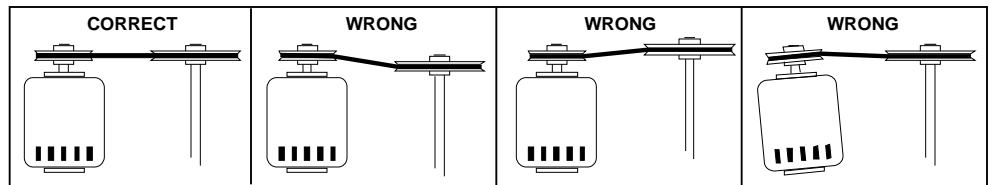
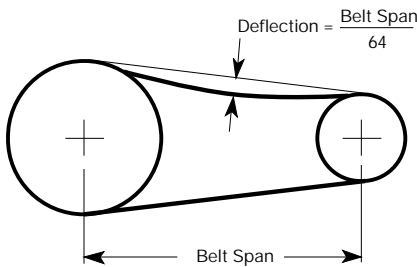

**5. REMOVAL OF DUST AND DIRT** - Model TAUB-CA and TAUB-L/H fans require very little attention when moving clean air. If Exhausting dirty or contaminated air, the propeller and butterfly damper assembly should be cleaned periodically. Accumulations of dirt and debris on the propeller blades may cause an unbalanced condition resulting in excessive vibration and premature failure of the propeller and bearings. Excessive buildup of dirt on the damper blades may cause binding and sticking blade hinges resulting in loss of fan performance. CAUTION: See **\*\*WARNING\*\*** on page 1.

Periodically, the motor weather cover should be removed and the motor cleaned of dirt and debris. Cleaning should be limited to the motor exterior. Removal of dust and dirt from the motor will assist in motor cooling. Motors should never be sprayed directly with water, steam or solvents.

## ROUTINE MAINTENANCE FOR DIRECT DRIVE FANS

CAUTION: See **\*\*WARNING\*\*** on page 1.

Once the fan has been put into operation, periodic maintenance should be scheduled to assure it's reliability and performance. The following items should be checked as a part of this maintenance schedule:

**1. FASTENERS AND SET SCREWS** - Normal fan vibration has a tendency to loosen mechanical fasteners. Periodic inspection should include checking all fasteners and set screws, including the propeller fasteners, for tightness.

## ROUTINE MAINTENANCE FOR DIRECT DRIVE FANS (Cont.)

3. **LUBRICATION** - Lubrication of motors is intended only when fittings are provided. Many fractional horsepower motors are permanently lubricated and require no further lubrication. Motors supplied with grease fittings should be greased in accordance with the manufacturers directions on the motor nameplate.

5. **REMOVAL OF DUST AND DIRT** - Model TAUD fans require very little attention when moving clean air. If exhausting dirty or contaminated air, the propeller and butterfly damper assembly should be cleaned periodically. Accumulations of dirt and debris on the propeller blades may cause an unbalanced condition resulting in excessive vibration and premature failure of the propeller and motor. Excessive buildup of dirt on the damper blades may cause hinges to stick and bind resulting in loss of fan performance. **CAUTION: See \*\*WARNING\*\* on page 1.**

Cleaning of the motor should be limited to the exterior. Removal of dust and dirt will assist in motor cooling. Motors should never be sprayed directly with water, steam or solvents.

### PARTS LIST

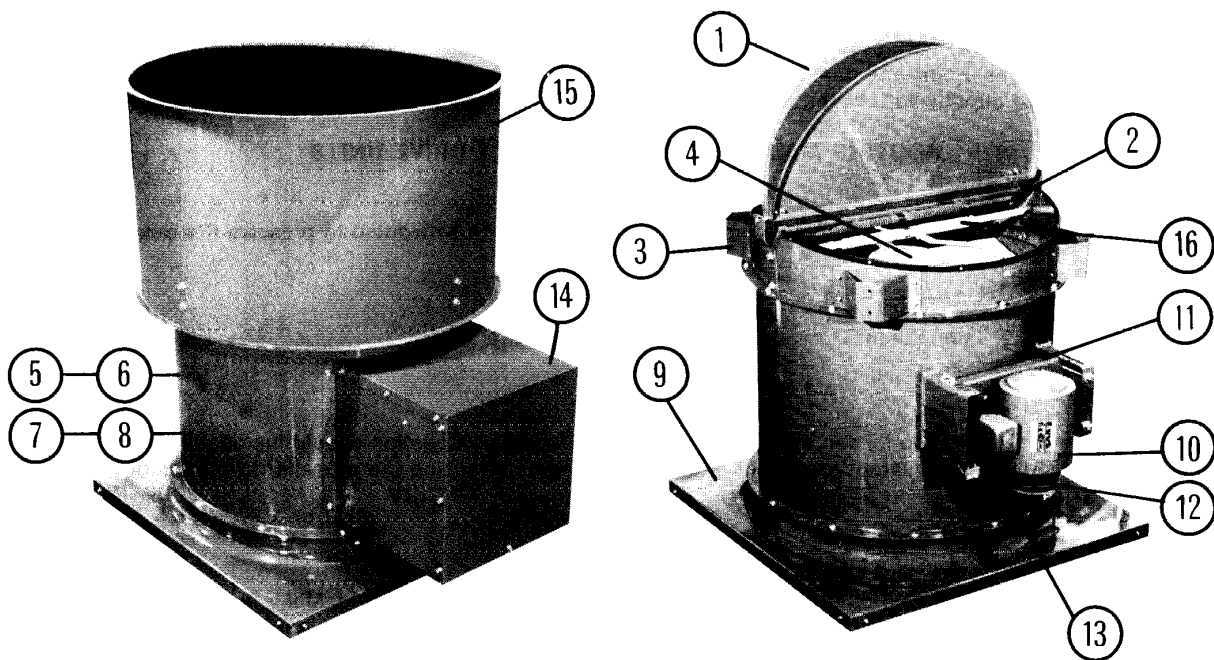

Always provide the fan serial number when requesting parts or information.

- |                               |                               |                                 |
|-------------------------------|-------------------------------|---------------------------------|
| 1. Butterfly Dampers          | 6. Shaft Bearings (Not Shown) | 12. Motor Pulley                |
| 2. Damper Hinge Rod           | 7. Bearing Cover (Not Shown)  | 13. Belt(s)                     |
| 3. Windband Bracket           | 8. Shaft Pulley (Not Shown)   | 14. Weather Cover               |
| 4. Propeller                  | 9. Curb Cap                   | 15. Windband                    |
| 5. Fan Shaft (Not Shown)      | 10. Motor                     | 16. Fusible Link Damper Lifters |
| 6. Shaft Bearings (Not Shown) | 11. Motor Plate               |                                 |

### WARRANTY

Greenheck warrants this equipment to be free from defects in material and workmanship for a period of one year from the purchase date.

Any units or parts which prove defective during the warranty period will be replaced at our option when returned to our factory, transportation prepaid.

Motors are warranted by the motor manufacturer for a period of one year. Should motors furnished by Greenheck prove defective during this period, they should be returned to the nearest authorized motor service station. Greenheck will not be responsible for any installation or removal costs.