

### Application

Model SMD-203 is a leakage rated smoke damper with 3 Vee style blades. The SMD-203 has been qualified to 2000 fpm and 4 in. w.g. for operational closure in emergency smoke control situations. Model SMD-203 may be installed vertically (with blades running horizontally) or horizontally and is rated for airflow and leakage in either direction.

### Ratings

#### UL 555S Leakage Rating

Leakage Class: III

Operational Rating—Limits are actuator dependant

Maximum Velocity: 2000 fpm

Maximum Pressure: 4 in. wg

Maximum Temperature: 350°F—Depending on actuator

### Standard Construction

**Frame:** 5 in. x 1 in. galv. steel hat channel with reinforced corners (meets 13 ga. criteria). A low profile head and sill are used on sizes less than 17 in. high to maximize free area and performance.

**Blades:** 16 ga. galvanized steel, reinforced with 3 longitudinal structurally designed vee's.

**Seals:** Extruded silicone rubber blade seals.  
Flexible stainless steel jamb seals.

**Linkage:** Concealed in jamb.

**Axles:** 1/2 in. dia. plated steel.

**Bearings:** Bronze sleeve type.

### Size Limitations

**Minimum Size:** 8 in. W x 6 in. H

**Maximum Size:** Single Section: 36 in. W x 36 in. H  
32 in. W x 50 in. H

### Optional Features

- Galvanized steel sleeves.
- Stainless steel bearings
- OCI (Open closed indication switches)
- Electric or pneumatic actuators to accomplish smoke management and system functions.

Model SMD-203 meets the requirements for smoke dampers established by:

**National Fire Protection Association**

NFPA Standards 90A, 92A, 92B & 101

**BOCA National Building Codes**

**ICBO Uniform Building Codes**

**SBCCI Standard Building Codes**

"UL CLASSIFIED (see complete marking on product)"

"UL CLASSIFIED to Canadian safety standards (see complete marking on product)"

Standard 555S (Listing #R13447)



Greenheck certifies that the model SMD-203 shown herein is licensed to bear the AMCA Seal. The ratings shown are based on tests and procedures performed in accordance with AMCA Publication 511 and comply with the requirements of the AMCA Certified Ratings Programs. The AMCA Certified Ratings Seal applies to air performance ratings only.

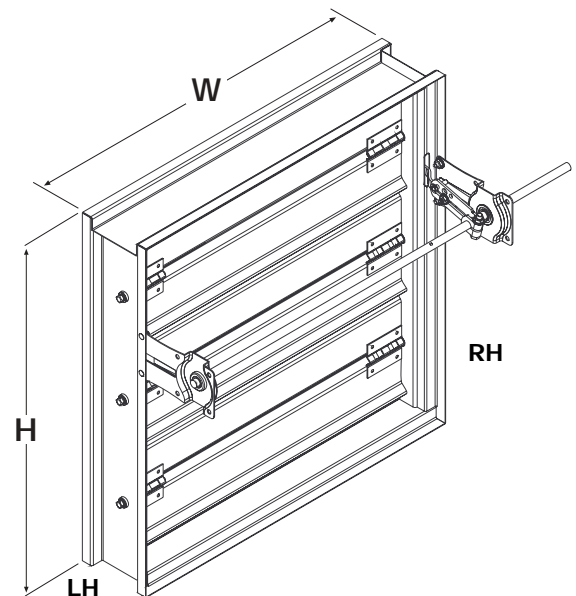

\* W&H dimensions furnished approximately 1/4 in. undersize.  
(Add sleeve thickness for overall sleeved damper dimension)  
Right hand drive is shown. Left hand drive is available upon request.

This pressure drop testing was conducted in accordance with AMCA Standard 500 using the three configurations shown. All data has been corrected to represent standard air at a density of 0.075 lb/ft<sup>3</sup>.

Actual pressure drop found in any HVAC system is a combination of many factors. This pressure drop information along with an analysis of other system influences should be used to estimate actual pressure losses for a damper installed in a given HVAC system.

## AMCA Test Figures

**Figure 5.3** Illustrates a fully ducted damper. This configuration has the lowest pressure drop of the three test configurations because entrance and exit losses are minimized by straight duct runs upstream and downstream of the damper.

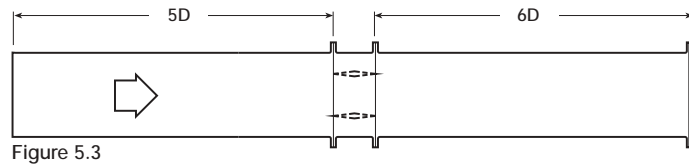

Figure 5.3

**Figure 5.2** Illustrates a ducted damper exhausting air into an open area. This configuration has a lower pressure drop than Figure 5.5 because entrance losses are minimized by a straight duct run upstream of the damper.

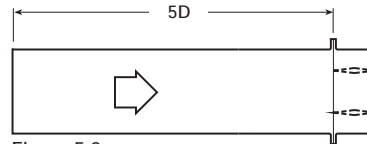

Figure 5.2

$$D = \sqrt{\frac{4(W)(H)}{3.14}}$$

**Figure 5.5** Illustrates a plenum mounted damper. This configuration has the highest pressure drop because of extremely high entrance and exit losses due to the sudden changes of area in the system.

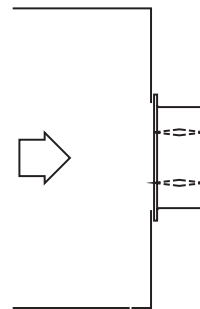

Figure 5.5

## Pressure Drop Calculations

As explained in chapter 32 of the 1997 ASHRAE fundamentals handbook, pressure drop is a function of two variables: pressure velocity and a dimensionless parameter called the pressure loss coefficient ( $C_o$ ).

To calculate the pressure drop across your damper: first select the AMCA test figure shown above that most closely resembles how your damper will be mounted, then substitute the duct face velocity and the appropriate damper pressure loss coefficient ( $C_o$ ) found on the following page into equation 1.

**Equation 1:**  $\Delta p = C_o * (V / 4005)^2$

where  $\Delta p$  = pressure drop measured in inches wg  
 $C_o$  = pressure drop coefficient  
 $V$  = Face velocity measured in fpm

**Example:** Calculate the pressure drop of a 24" x 24" damper in a fully ducted configuration (fig 5.3) that sees a face velocity of 1500 fpm.

Using the pressure loss coefficient table corresponding to AMCA fig 5.3 it can be seen that the  $C_o$  value for a 24" x 24" damper is 0.65. Substituting  $C_o$  and the velocity into equation 1:

$$\Delta p = 0.65 * (1500 / 4005)^2$$

$$\Delta p = 0.091 \text{ in. wg}$$



Greenheck certifies that the model SMD-203 shown herein is licensed to bear the AMCA Seal. The ratings shown are based on tests and procedures performed in accordance with AMCA Publication 511 and comply with the requirements of the AMCA Certified Ratings Programs. The AMCA Certified Ratings Seal applies to air performance ratings only.



# DIMENSIONAL DATA

# SPECIFICATIONS

## Damper Sizing Information

The Single Section figure below shows maximum damper section size.

Single Section

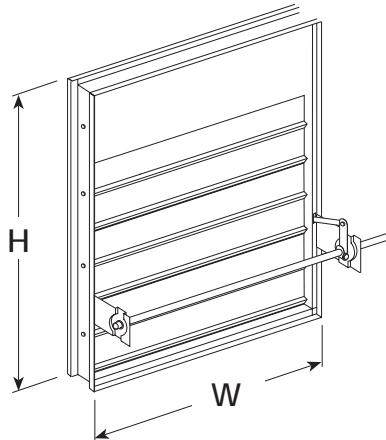

Sideplate

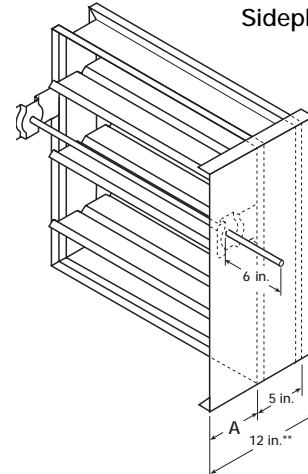

## Damper Sideplate and Sleeve Dimensional Data

The drawings above and below illustrate the factory standard sideplate and sleeve mountings for the SMD-203. The standard "A" dimensions listed in the table provide adequate space for the mounting of actuators and controls.

	"A" Dimension*			
	Standard	Minimum	Maximum	Sideplate
All Dampers <sup>1</sup>	7 <sup>3</sup> / <sub>16</sub> in.	5 <sup>3</sup> / <sub>8</sub> in.	16 in.	6 <sup>3</sup> / <sub>16</sub> in.
When H is < 11 in. w/OCI, RRL, or TOR	12 in.	12 in.	16 in.	12 in.
When H is > 11 in. w/OCI, RRL, or TOR	7 <sup>3</sup> / <sub>16</sub> in.	7 <sup>3</sup> / <sub>16</sub> in.	16 in.	6 <sup>3</sup> / <sub>16</sub> in.

<sup>1</sup> All dampers w/o OCI, RRL, or TOR.

\*Consult factory for any other requests.

Note: Entire damper frame is not required to be installed within the wall.

The damper blades, when closed, should be contained in the wall.

Sleeve

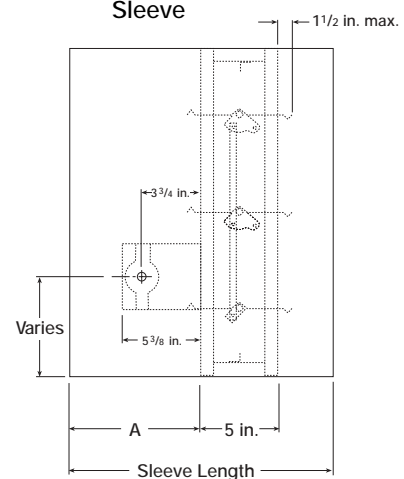

## Specifications

Smoke Dampers meeting the following specifications shall be furnished and installed where shown on plans and/or as described in schedules. Dampers shall meet the requirements of the latest edition of NFPA 90A, 92A and 92B.

Dampers shall be tested, rated and labeled in accordance with the latest edition of UL Standard 555S. Dampers shall be UL labeled for use in dynamic systems. The damper shall have a dynamic closure airflow rating equal to or greater than the airflow at the damper's installed location and a dynamic closure pressure rating of 4 in. wg.

Dampers shall have a UL 555S Leakage rating of Class III and a Temperature rating of 350°F. Dampers shall have a UL 555S operational airflow rating equal to or greater than the airflow at its installed location and an operational pressure rating of 4 in. wg. Damper actuators shall be factory mounted and qualified for use with the damper in accordance with UL 555S. Damper actuators shall be (specifier select one of the following) electric type for 120 (or 24) volt operation or pneumatic type for 20 psi minimum operation. Manufacturers submittal data shall indicate actuator space requirements around the damper.

All UL 555S Dynamic Closure Ratings, Operational Ratings and Leakage Ratings shall be qualified for airflow and pressure in either

direction through the damper. UL ratings shall allow for mounting damper vertically (with blades running horizontal) or horizontally.

The Damper Manufacturers submittal data shall certify all air performance pressure drop data is licensed in accordance with the AMCA Certified Ratings Program for Test Figures 5.2, 5.3 and 5.5. Damper air performance data shall be developed in accordance with the latest edition of AMCA Standard 500-D. Dampers shall be labeled with the AMCA Air Performance Seal.

Damper blades shall be 16 ga. galvanized steel 3 Vee type with three longitudinal grooves for reinforcement. Blades shall be completely symmetrical relative to their axle pivot point, presenting identical resistance to airflow and operation in either direction through the damper (blades that are non-symmetrical relative to their axle pivot point or utilize blade stops larger than 1/2 in. are unacceptable).

Damper frames shall be galvanized steel formed into a structural hat channel shape with reinforced corners. Bearings shall be sintered bronze sleeve type rotating in extruded holes in the damper frame. Jamb seals shall be stainless steel compression type.

Basis of design is Greenheck Model SMD-203.



Submittal SMD-203-FS  
Rev. 1 August 2001  
Copyright © 2001 Greenheck Fan Corp.