

SELECTION CHARTS

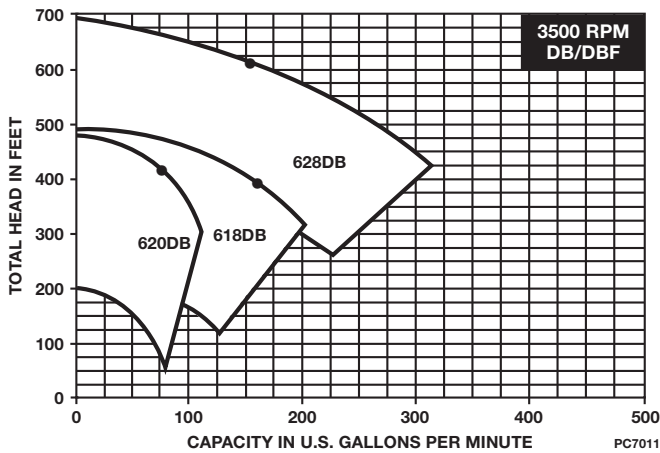

• Indicates 2' NPSH Requirement position

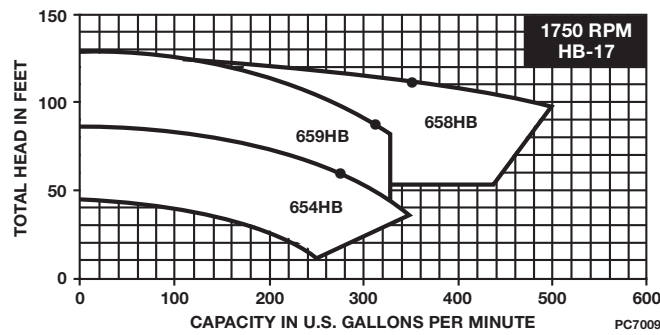
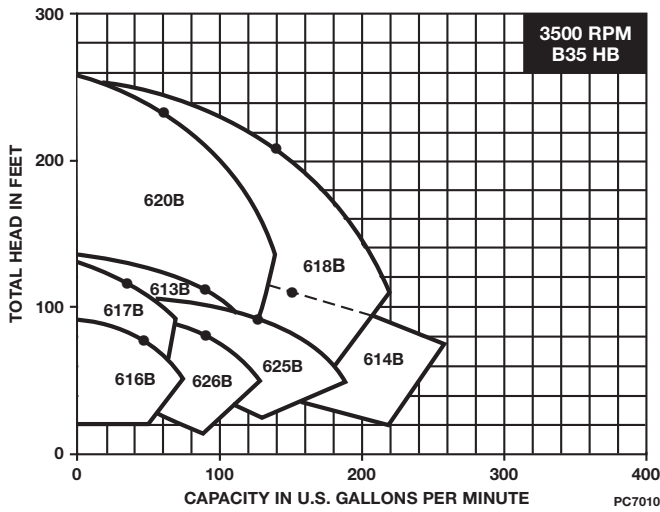
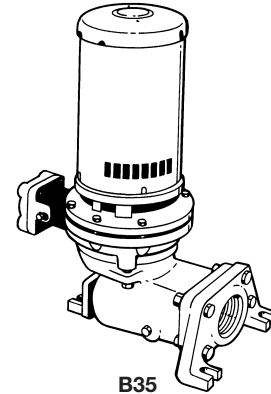

**B35
VERTICAL FLANGE MOUNTED
OR VERTICAL FOOT MOUNTED**

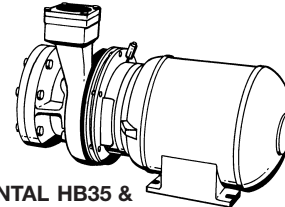

**HORIZONTAL HB35 &
HORIZONTAL HB17**

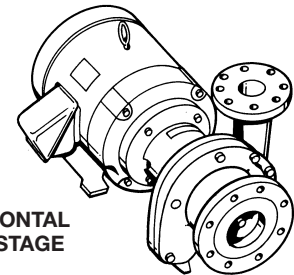

**HORIZONTAL
DB 2-STAGE**

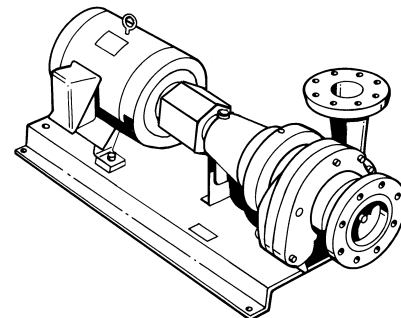

DB-F BASE MOUNTED HORIZONTAL 2-STAGE

**Domestic™ Series B35™, HB35,
HB17, DB and DB-F
2' NPSH Centrifugal Pump Performance Curves**

Series B Group of 2 Ft. N.P.S.H. CENTRIFUGAL PUMP Performance Curves

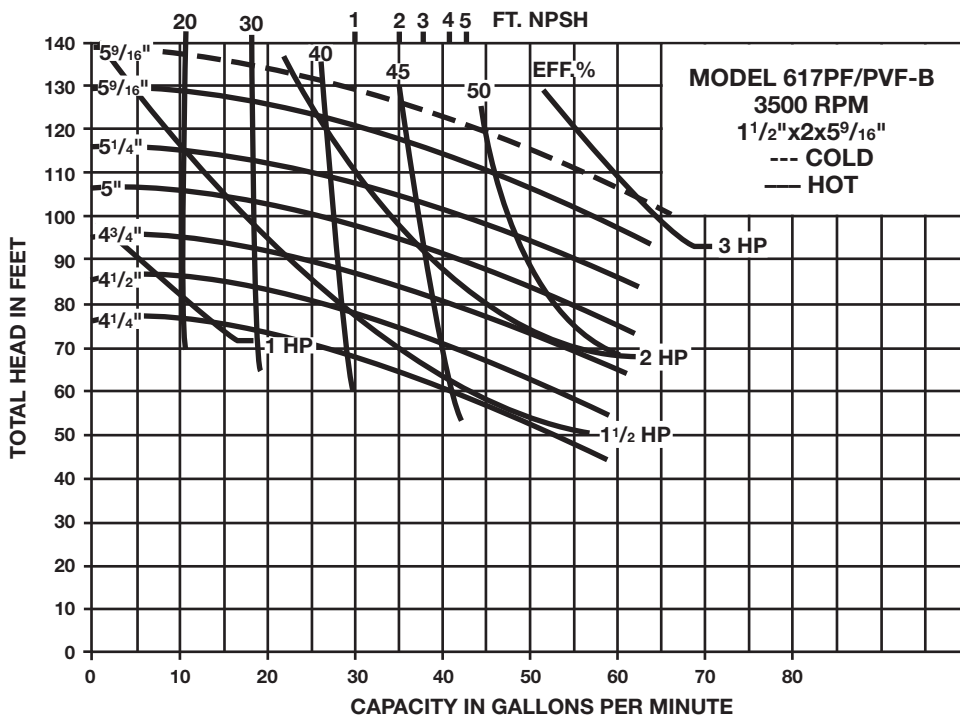
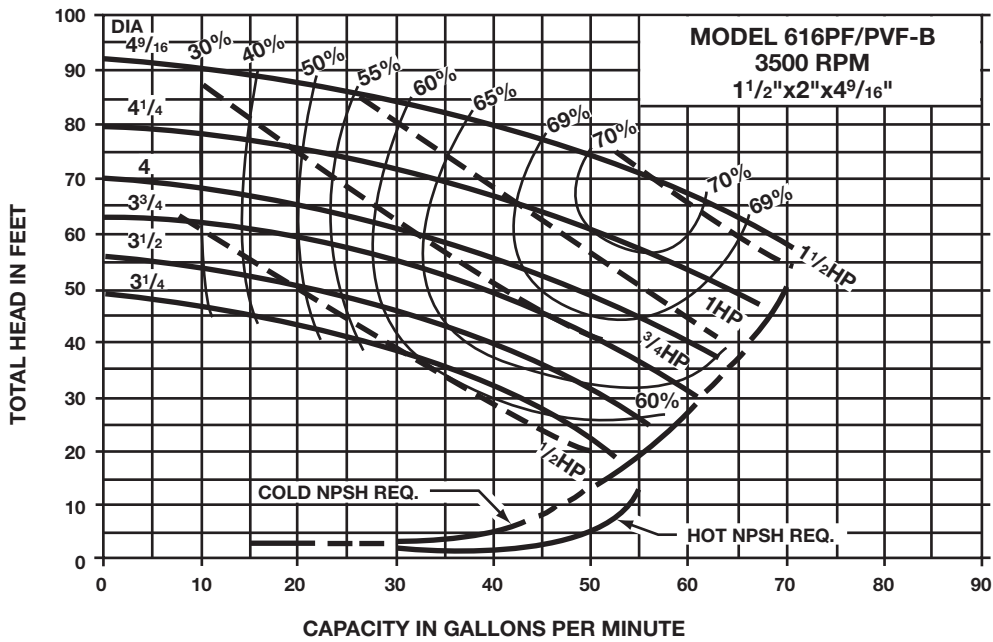

Domestic Pump

USA
Bell & Gossett
8200 N. Austin Avenue
Morton Grove, IL 60053
Phone: (847) 966-3700
Facsimile: (847) 966-9052
<http://www.domesticpump.com>

Series B Group of 2 Ft. N.P.S.H. CENTRIFUGAL PUMP Performance Curves

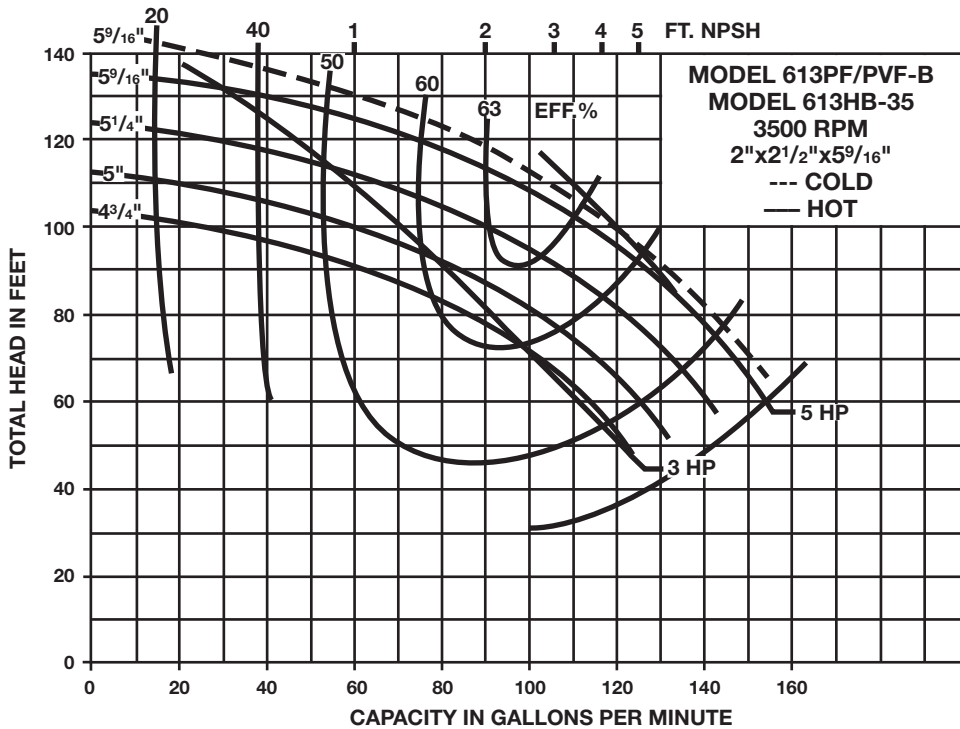

Available in
5 Hp only

Performance Characteristic Curves

Impellers are trimmed to nearest 1/16" dia. Final selection for impeller sizing remains with the factory.

NPSH shown across top of curve is in ft. of water head.

Horsepower curves do not include service factor.

Max. suction pressure 35 psig.

Max. water temp. 250°F.

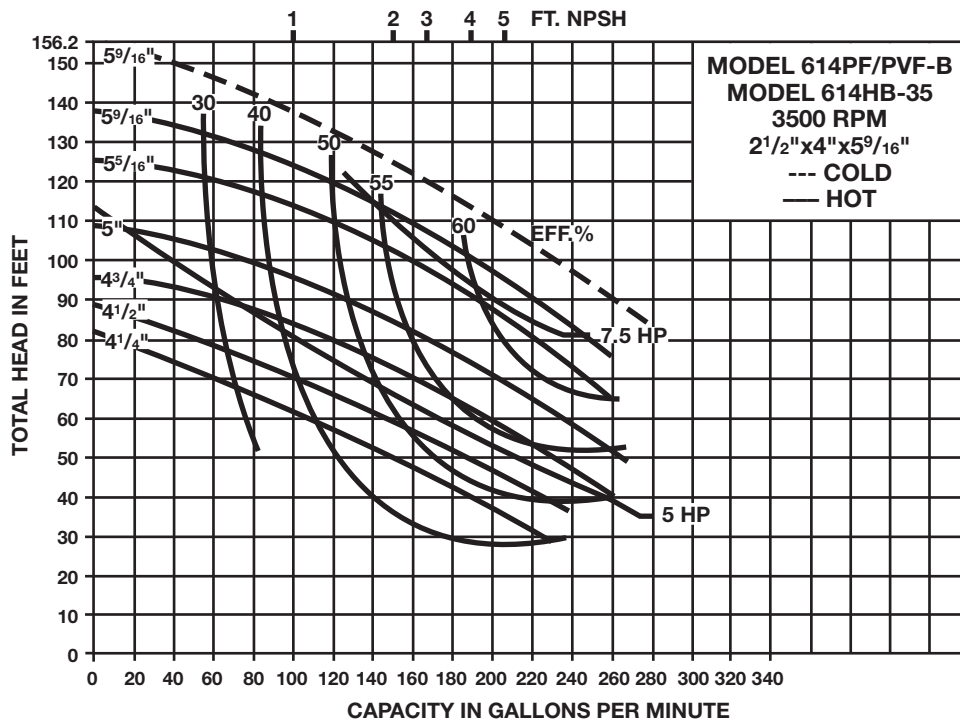

Performance Characteristic Curves

Impellers are trimmed to nearest 1/16" dia. Final selection for impeller sizing remains with the factory.

NPSH shown across top of curve is in ft. of water head.

Horsepower curves do not include service factor.

Max. suction pressure 35 psig.

Max. water temp. 250°F.

Series B Group of 2 Ft. N.P.S.H. CENTRIFUGAL PUMP Performance Curves

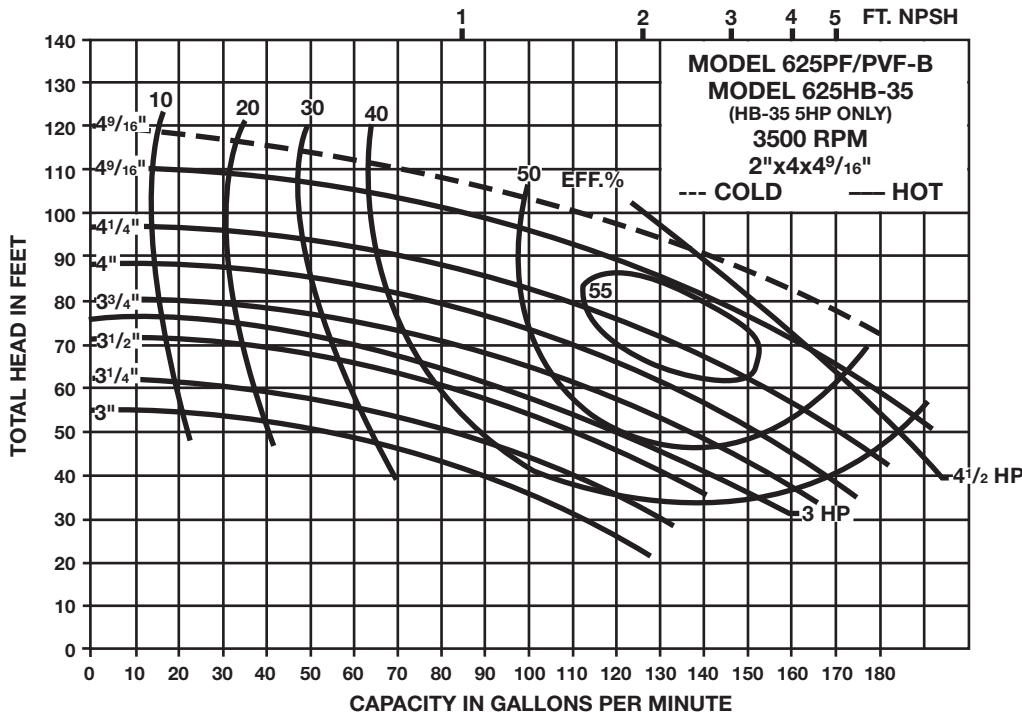

Performance Characteristic Curves

Impellers are trimmed to nearest 1/16" dia. Final selection for impeller sizing remains with the factory.

NPSH shown across top of curve is in ft. of water head.

Horsepower curves do not include service factor.

Max. suction pressure 35 psig.

Max. water temp. 250°F.

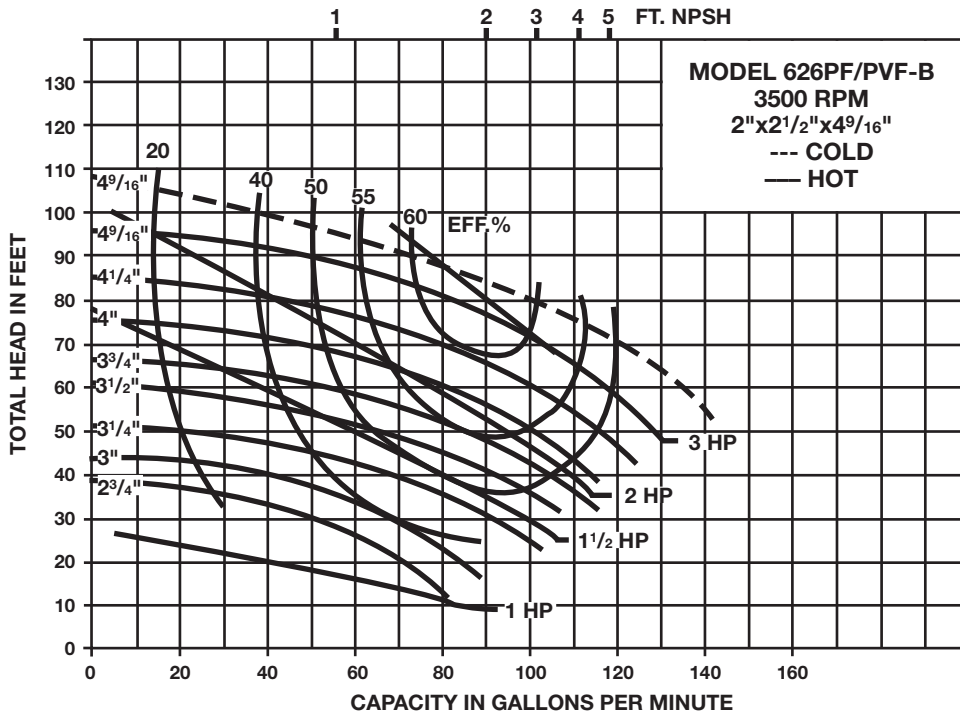

Performance Characteristic Curves

Impellers are trimmed to nearest 1/16" dia. Final selection for impeller sizing remains with the factory.

NPSH shown across top of curve is in ft. of water head.

Horsepower curves do not include service factor.

Max. suction pressure 35 psig.

Max. water temp. 250°F.



Domestic Pump

USA
 Bell & Gossett
 8200 N. Austin Avenue
 Morton Grove, IL 60053
 Phone: (847) 966-3700
 Facsimile: (847) 966-9052
<http://www.domesticpump.com>

Series B Group of 2 Ft. N.P.S.H. CENTRIFUGAL PUMP Performance Curves

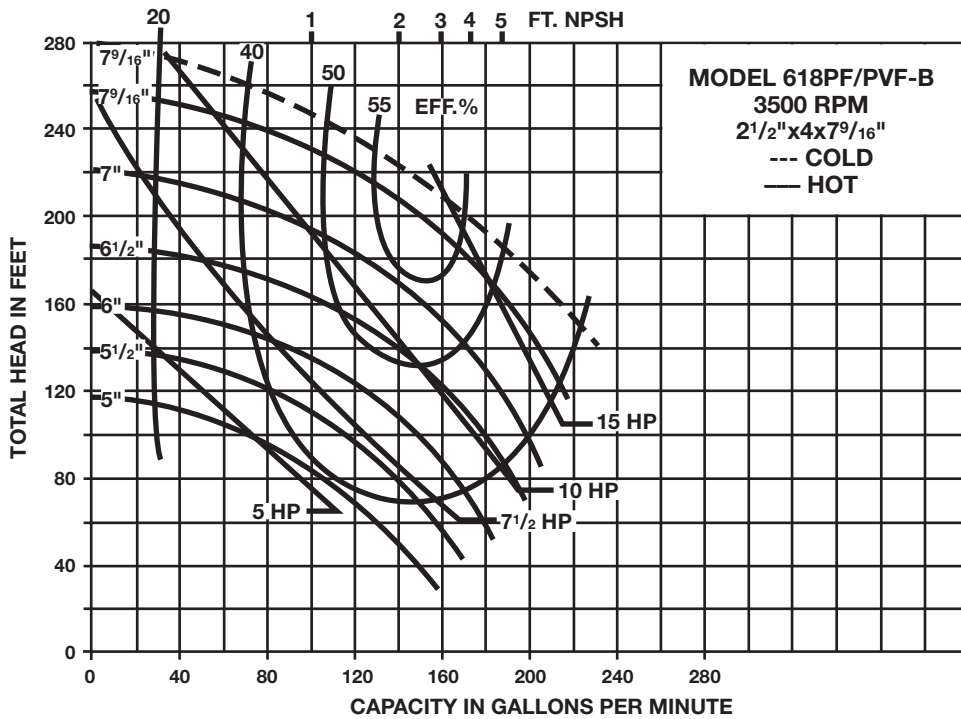

Performance Characteristic Curves

Impellers are trimmed to nearest 1/16" dia. Final selection for impeller sizing remains with the factory.

NPSH shown across top of curve is in ft. of water head.

Horsepower curves do not include service factor.

Max. suction pressure 35 psig.

Max. water temp. 250°F.

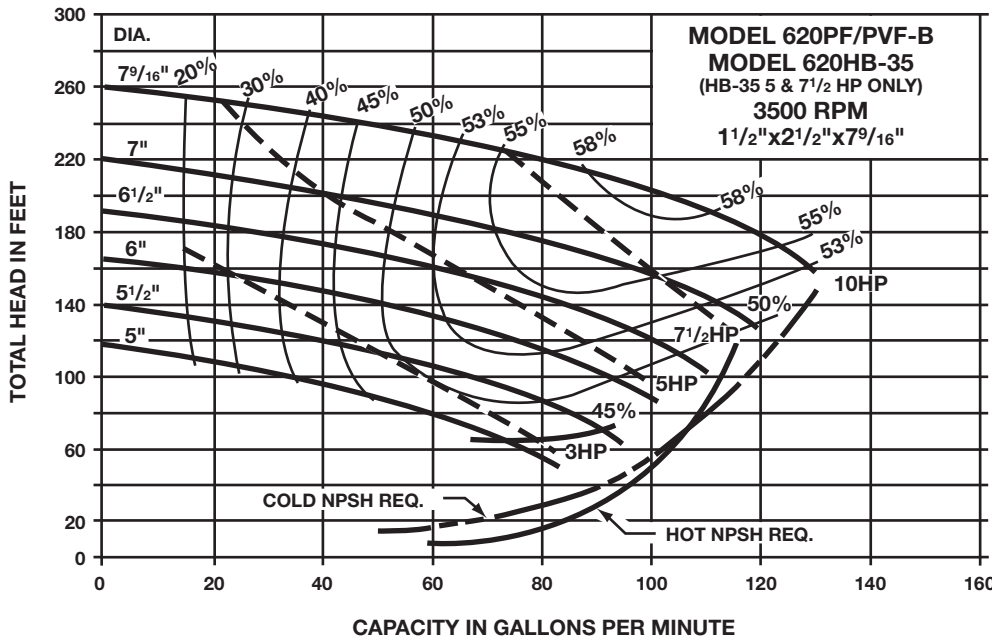

Performance Characteristic Curves

Impellers are trimmed to nearest 1/16" dia. Final selection for impeller sizing remains with the factory.

NPSH shown across top of curve is in ft. of water head.

Horsepower curves do not include service factor.

Max. suction pressure 35 psig.

Max. water temp. 250°F.

Series B Group of 2 Ft. N.P.S.H. CENTRIFUGAL PUMP Performance Curves

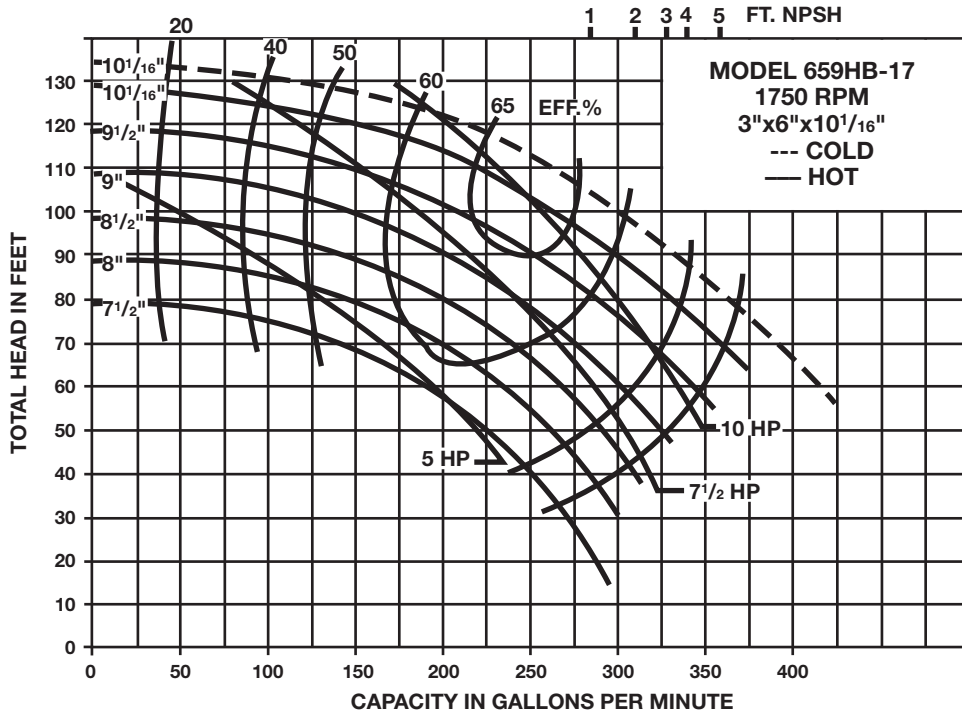

Performance Characteristic Curves

Impellers are trimmed to nearest 1/16" dia. Final selection for impeller sizing remains with the factory.

NPSH shown across top of curve is in ft. of water head.

Horsepower curves do not include service factor.

Max. suction pressure 35 psig.

Max. water temp. 250°F.



ISO 9001 Certified

Domestic Pump

USA
 Bell & Gossett
 8200 N. Austin Avenue
 Morton Grove, IL 60053
 Phone: (847) 966-3700
 Facsimile: (847) 966-9052
<http://www.domesticpump.com>

Series B Group of 2 Ft. N.P.S.H. CENTRIFUGAL PUMP Performance Curves

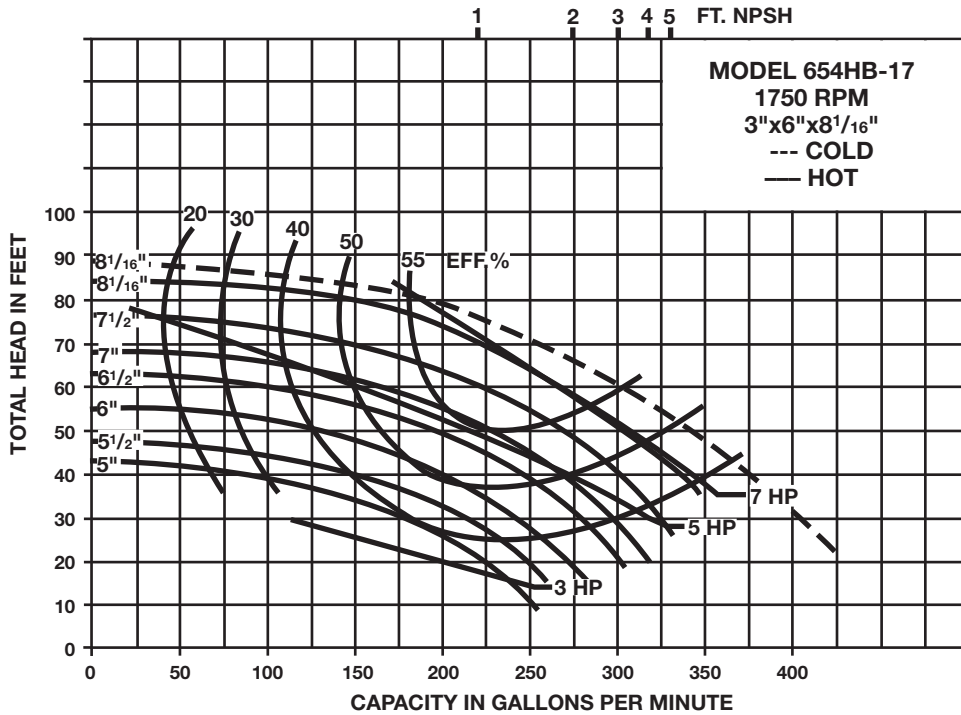

Performance Characteristic Curves

Impellers are trimmed to nearest 1/16" dia. Final selection for impeller sizing remains with the factory.

NPSH shown across top of curve is in ft. of water head.

Horsepower curves do not include service factor.

Max. suction pressure 35 psig.

Max. water temp. 250°F.

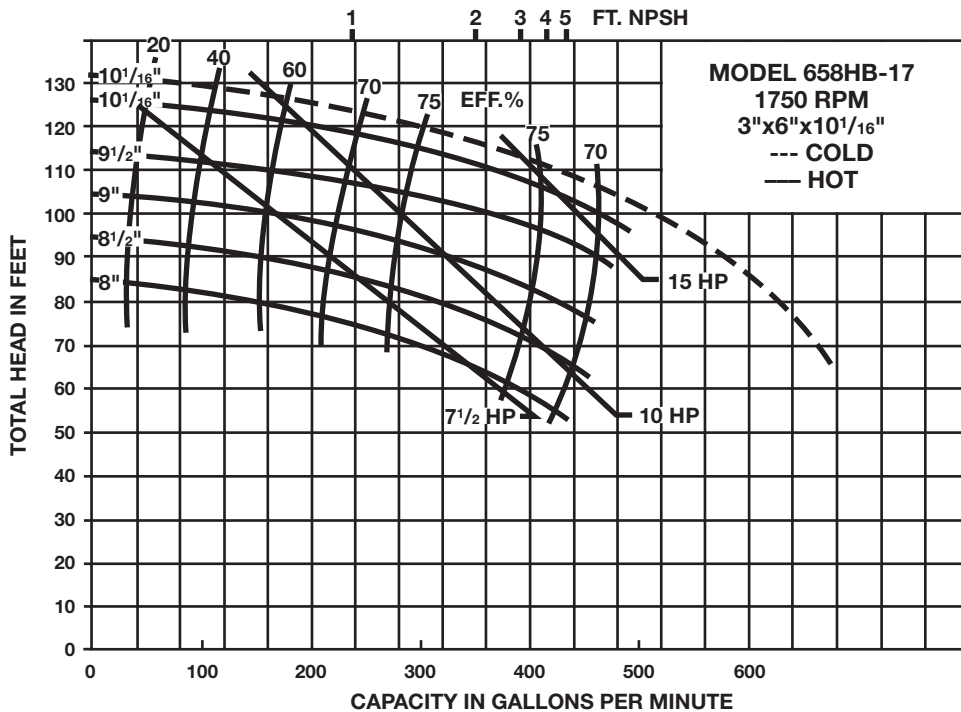

Performance Characteristic Curves

Impellers are trimmed to nearest 1/16" dia. Final selection for impeller sizing remains with the factory.

NPSH shown across top of curve is in ft. of water head.

Horsepower curves do not include service factor.

Max. suction pressure 35 psig.

Max. water temp. 250°F.

Series B Group of 2 Ft. N.P.S.H. CENTRIFUGAL PUMP Performance Curves

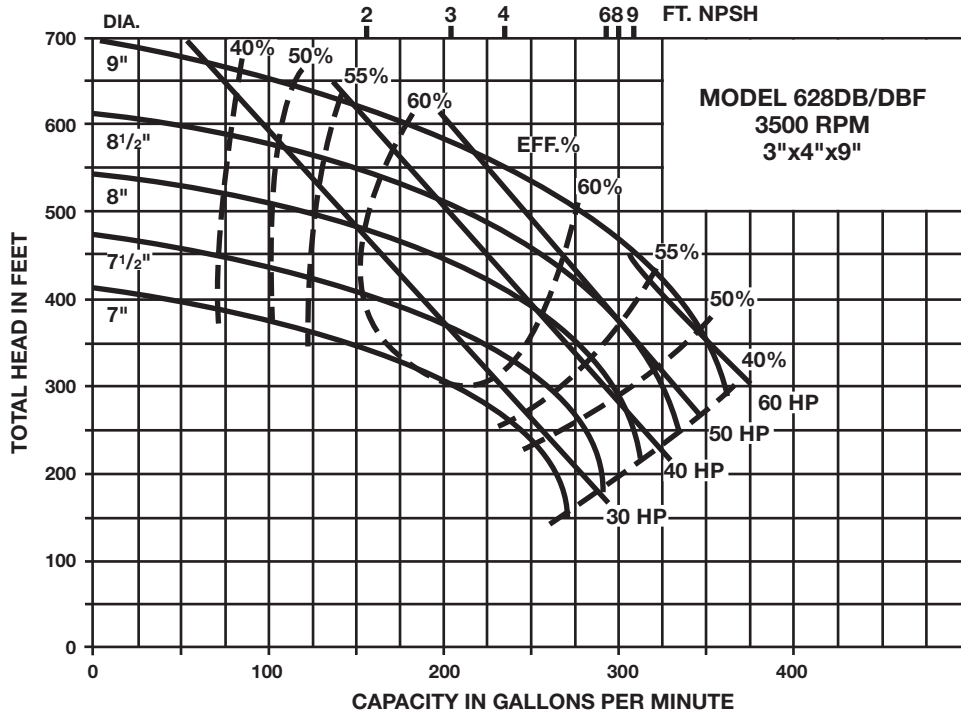

Performance Characteristic Curves

Impellers are trimmed to nearest 1/16" dia. Final selection for impeller sizing remains with the factory.

NPSH shown across top of curve is in ft. of water head.

Horsepower curves do not include service factor.

Max. suction pressure 35 psig.

Max. water temp. 250°F.



**ISO 9001
Certified**

Domestic Pump

USA
Bell & Gossett
8200 N. Austin Avenue
Morton Grove, IL 60053
Phone: (847) 966-3700
Facsimile: (847) 966-9052
<http://www.domesticpump.com>

Series B Group of 2 Ft. N.P.S.H. CENTRIFUGAL PUMP Performance Curves

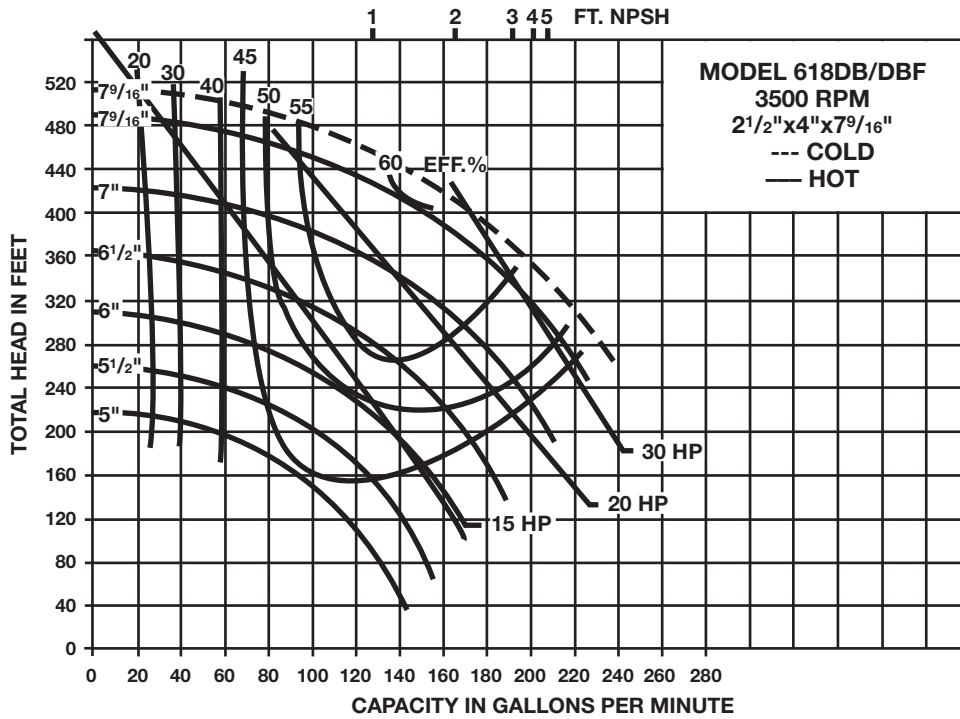

Performance Characteristic Curves

Impellers are trimmed to nearest 1/16" dia. Final selection for impeller sizing remains with the factory.

NPSH shown across top of curve is in ft. of water head.

Horsepower curves do not include service factor.

Max. suction pressure 35 psig.

Max. water temp. 250°F.

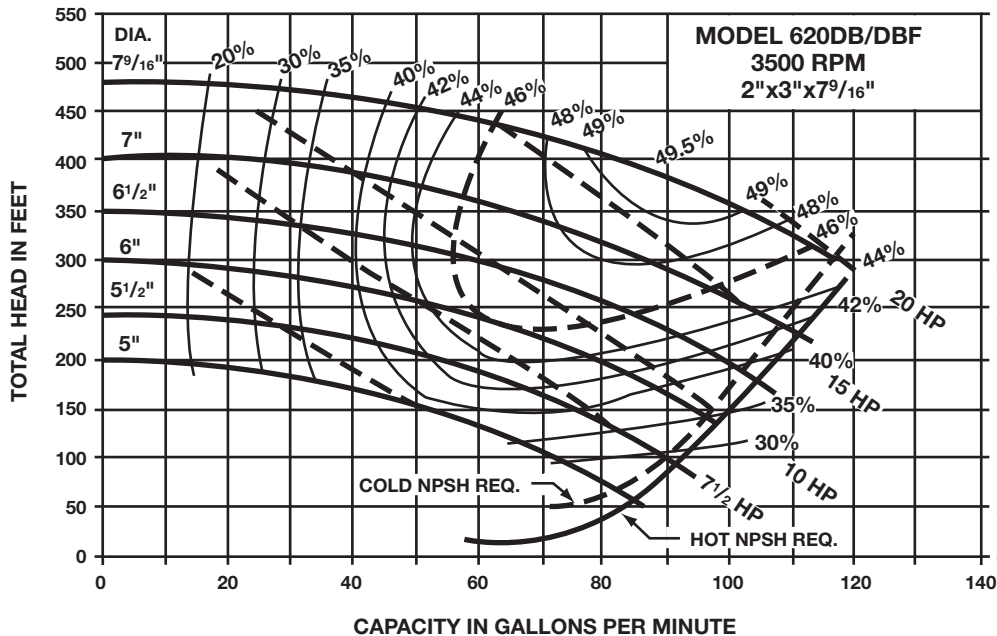

Performance Characteristic Curves

Impellers are trimmed to nearest 1/16" dia. Final selection for impeller sizing remains with the factory.

NPSH shown across top of curve is in ft. of water head.

Horsepower curves do not include service factor.

Max. suction pressure 35 psig.

Max. water temp. 250°F.

TABLE OF CONTENTS

3500 RPM PUMPS

MODEL	DISCHARGE (inches)	SUCTION* (PF Flange or PVF/HB NPT)	MAX. IMPELLER (inches)	PAGE
613PF/PVF-B, HB-35	2	"A" (2 ¹ / ₂)	5 ⁹ / ₁₆	S650B
614PF/PVF-B, HB-35	2 ¹ / ₂	"D" (4)	5 ⁹ / ₁₆	S650B
616PF/PVF-B	1 ¹ / ₂	"A" (2)	4 ⁹ / ₁₆	S650B
617PF/PVF-B	1 ¹ / ₂	"A" (2)	5 ⁹ / ₁₆	S650B
618PF/PVF-B, HB-35	2	"D" (4)	7 ⁹ / ₁₆	S651B
620PF/PVF-B, HB-35	1 ¹ / ₂	"A" (2 ¹ / ₂)	7 ⁹ / ₁₆	S651B
625PF/PVF-B, HB-35	2	"D" (4)	4 ⁹ / ₁₆	S651B
626PF/PVF-B	2	"A" (2 ¹ / ₂)	4 ⁹ / ₁₆	S651B
618DB/DB-F	2 ¹ / ₂	4	7 ⁹ / ₁₆	S653B
620DB/DB-F	2	3	7 ⁹ / ₁₆	S653B
628DB/DB-F	3	4	9	S653B

1750 RPM PUMPS

654HB/17	3	6	8 ¹ / ₁₆	S652B
658HB/17	3	6	10 ¹ / ₁₆	S652B
659HB/17	3	6	10 ¹ / ₁₆	S652B

* Refer to submittal S421 for detailed dimensions on Style PF suction flanges
 HB-35 and HB-17 Suction connection is a 125# ASA flange
 DB and DB-F suction connections are 125# ASA flanges, discharge connections are
 250# ASA flange (except 628-400# ASA flange)

PERFORMANCE CURVE CHARACTERISTICS

- Impellers are trimmed to the nearest 1/16" increment to supply required capacity. Responsibility for final impeller sizing remains with ITT Bell & Gossett.
- Maximum Suction Pressure for pumps is 35 psi. Maximum Water Temperature is 250°F.
- Horsepower curves do not include motor service factor. Typical motor service factors are as follows:
 ODP Enclosure – 1.15 Minimum (up to 1.75 are used when available.)
 TEFC Enclosure – 1.15 Minimum (up to 1.75 are used when available.)
 Exp. Proof Enc. – 1.0
- NPSH Required is provided for cold (120°F and below) and hot water (above 120°F) applications. NPSH Required is determined by utilizing a vacuum pump to equalize atmospheric pressure and vapor pressure and then measuring the required static head of water for non-cavitating pump operation.
- Pumps available from stock are indicated on the respective performance curve by their part number.
- Pumps supplied for 45 GPM or less may include external orificing to facilitate matching of design conditions and to limit maximum motor loads. The orifice extends the pump discharge by 3¹/₂". Pumps for 15 GPM or less will be orificed and the orifice will have a 3/4 NPT discharge. Orificing is at the discretion of B&G.



Domestic Pump

USA
 Bell & Gossett
 8200 N. Austin Avenue
 Morton Grove, IL 60053
 Phone: (847) 966-3700
 Facsimile: (847) 966-9052
<http://www.domesticpump.com>