

**ANSUL.**

**Restaurant Fire Suppression Systems**

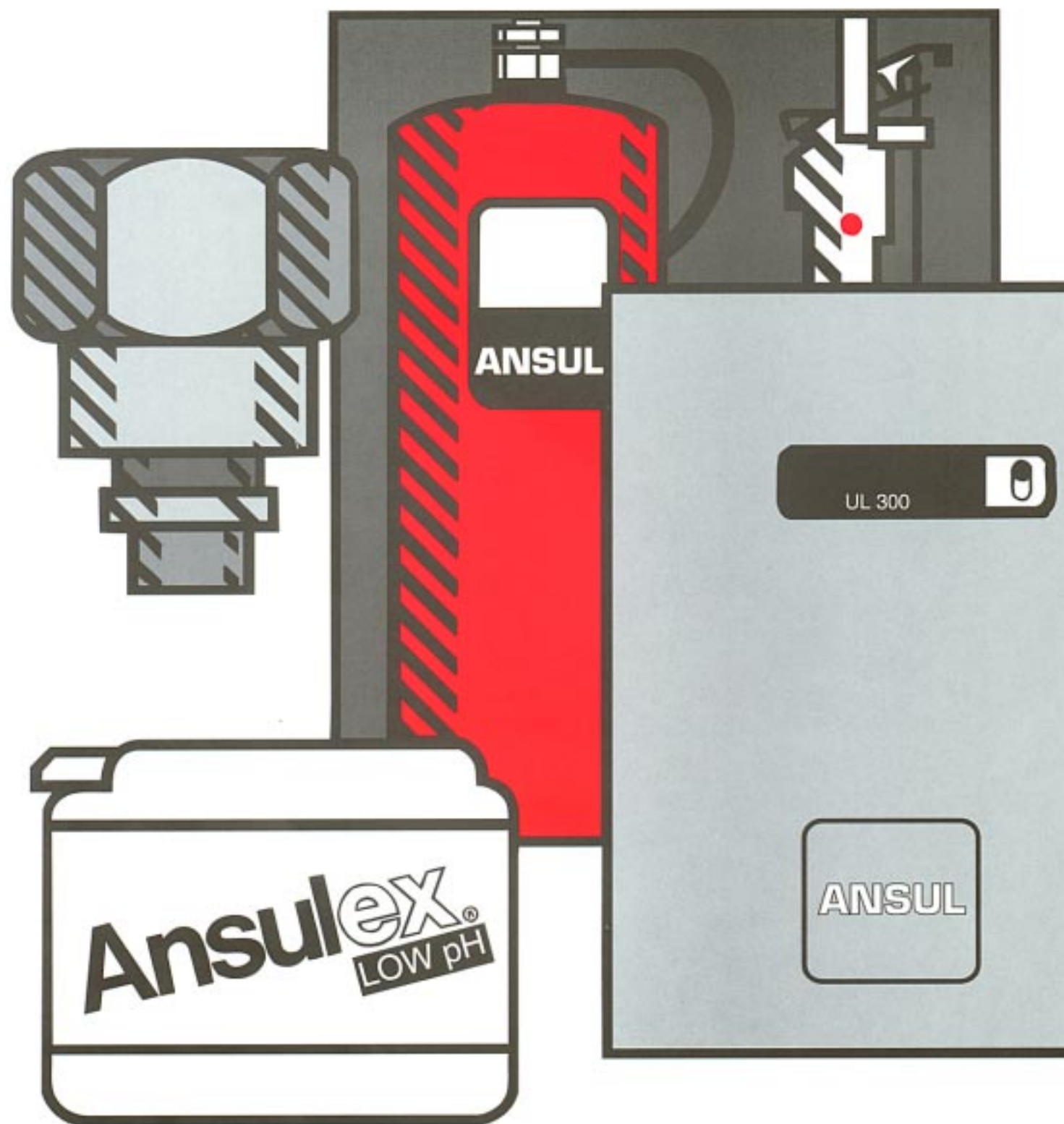

# The Ansul R-102 System. State-of-the-art in restaurant fire protection.

## Meeting the fire protection challenge.

In 1962, Ansul recognized that there was no effective system to combat dangerous and frightening restaurant fires. Dangerous because a fire can begin on a cooking appliance or in a hood or ductwork and quickly spread to involve an entire kitchen or restaurant. Frightening because statistics show that many restaurants never reopen after a major fire.

Ansul responded by developing the R-100 System, the first dry chemical fire suppression system designed exclusively for restaurant hood and duct protection. Restaurant owners, their insurance

companies and local fire inspectors were quick to recognize the new system as an effective solution to a major problem in the restaurant industry. A new and improved model, the Ansul R-101 Dry Chemical System replaced the initial R-100 unit a short time later.

In 1982, we introduced the Ansul R-102 Wet Chemical Restaurant Fire Suppression System. It was our answer to the industry's requests for 1) a system to protect the innovative new cooking appliances making their appearance in restaurants; and 2) a system with an extinguishing agent that is easier to clean

Over 30 years later, Ansul is still the most well-known name in restaurant fire protection. The high quality Ansul R-102 System is the preferred choice of architects who design kitchens, restaurateurs who own and operate them, insurance underwriters who provide coverage and fire inspectors who enforce the codes. These people know that without a system like the Ansul R-102, restaurant fire insurance would be difficult (if not impossible) to obtain at any price. And they trust the Ansul System to react quickly to a fire, automatically, before the fire has the opportunity to grow and spread.

In short, the Ansul R-102 System meets the fire challenge. It detects and suppresses fires with or without someone present... 24 hours a day. Its simple design permits quick and easy installation in single or multiple system configurations. So it can handle a single mesquite grill and hood or an entire kitchen full of cooking appliances.

And the Ansul R-102 System features a great, new extinguishing agent – ANSULEX® Low pH liquid fire suppressant – developed by Ansul scientists to provide better, cleaner fire protection. All good reasons why Ansul systems continue to protect more restaurants worldwide – exclusive gourmet, major chain, fast food or institutional – than any other brand.



## What makes the Ansul R-102 Restaurant System better?

### A better fire extinguishing agent.

ANSULEX Low pH liquid fire suppressant is a true breakthrough in restaurant fire protection. An equipment-friendly, near-neutral pH agent - it rapidly suppresses fires, cools hot surfaces to help prevent fire reflash, and cleans up fast. Which means that if fire strikes, you're back in business faster with less damage and clean-up cost.



**Great looking fire protection.** Architects and kitchen designers appreciate the fact that the Ansul R-102 System is designed with aesthetics in mind. The R-102 System's exclusive stainless steel enclosure blends right into the surroundings of today's modern kitchens. It's completely self-contained so components can be installed out of sight where they won't interfere with the visual appearance or operation of the kitchen.



**Simple to install, easy to service.** The design of the Ansul R-102 System features simplified piping and nozzle placement. And thanks to its cartridge operation, the Ansul R-102 System is reliable and can be recharged faster on site than stored pressure systems. All of which means a more flexible, efficient system that can be installed easier and with less disruption to your facility.

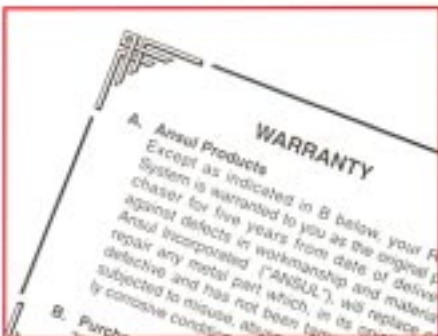

**Versatility.** The Ansul R-102 System comes in 1.5 and 3 gallon sizes. These systems can be connected in various configurations to provide even greater capacity. Also, our systems are designed to protect a wider variety of appliances found in today's food service facilities... everything from grills and gas radiant charbroilers to chain broilers and mesquite wood cooking appliances.

**Backed by the best warranty in the business.** Ansul's five year limited warranty makes it five times better than any other restaurant system. In addition, the first major servicing of the system, which includes both a regulator pressure test and hydrostatic test of the tank, doesn't come up for 12 years. That's a real money-saving advantage because most of our competitors require a major servicing of their systems after only six years.

**A distributor/installer network second to none.** Ansul's worldwide network of restaurant systems distributors is the largest in the fire protection industry. Our distributors are factory trained to take care of all your fire protection needs. They can accurately determine which Ansul system is best for you, quickly and efficiently install the system, and provide the proper maintenance and service. All with a minimum amount of disruption to your business. Your nearby Ansul Distributors...when it comes to fire protection, they're good people to know.

**Designed and built by Ansul.** Which means, simply, that like all Ansul equipment, your Ansul R-102 System is rugged, reliable, built to last and U.L. listed. Only the finest quality materials go into its manufacture. And only those systems which pass Ansul's rigid quality assurance tests ever make it out our doors. You have our word - and our name - on it.

ISO 9002  
Registered

## How the Ansul R-102 System works:

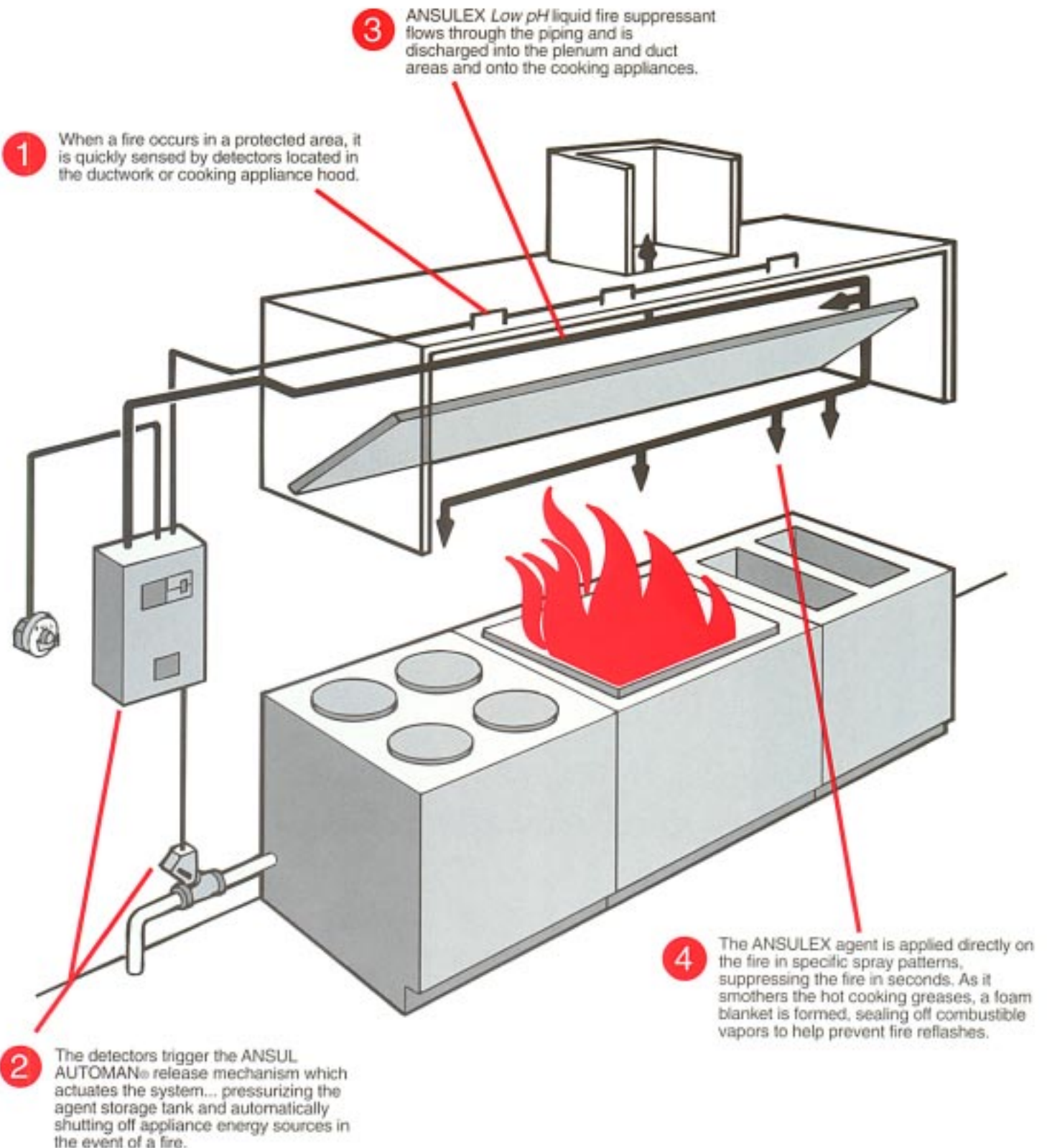

**Check out the features of the Ansul R-102 System...**

**Stainless Steel Enclosure...** An Ansul exclusive... aesthetically appealing... blends in with kitchen equipment... protects against tampering, damage.

**Agent Storage Tank...** Carbon steel... pressurized only when system is actuated... leak-proof... low maintenance... allows for fast, on-site recharging.

**Expellant Gas Cartridge...** Positive seal, self-contained, no maintenance of valve required. Nitrogen or carbon dioxide.



**ANSUL AUTOMAN Release...** Visible cocked/fired indicator... provides positive actuation of system... needs no periodic adjustment.

**Regulator...** 100 psi (6.9 bar) regulated pressure ensures constant flow of agent and consistent nozzle discharge pattern.

**Manual Pull Station...** Permits quick, sure manual actuation of the system by anyone regardless of fire fighting experience... break rod indicating manual system operation.

**Fuse Link Detection System...** Unique bracketing provides positive actuation upon exposure to heat.

**Hood-Seal Adaptors...** Threaded or compression-seal options provide tight seal for hood penetrations required for distribution pipe or detection lines... more aesthetically appealing than welded seal.



**Nozzles...** Designed to provide agent discharge coverage to each special hazard area... special blow-off caps reduce the risk of grease vapor contamination... chrome plating matches hood and appliances.

**Mechanical or Electrical Gas Shutoff Valve...** Shuts off fuel or power source upon detection of fire... clearly marked open/closed indicator.

**ANSULEX Low pH Agent...** At approximately 8.2, it has the lowest pH of any wet chemical restaurant agent on the market. As a result, it's safer for your equipment and employees... especially when compared to some other high pH restaurant agents.

# Typical Applications

There are various types of Ansul R-102 System configurations. Each is designed to economically fit particular sizes of kitchen equipment arrangements as indicated by the following examples. The type of system required to protect a specific installation or facility is determined by a careful analysis of the following variables:

- Size of duct, plenum
- Number and size of appliances
- Number of nozzles required
- Number and size of R-102 System tanks
- Number and type of accessory devices needed

Following an analysis of the hood/duct and appliances to be protected, your Authorized Ansul Restaurant Systems Distributor can recommend the proper system for your application in accordance with NFPA Standards 17, 17A and 96.

## Single Tank

3 gallon  
9 flow point

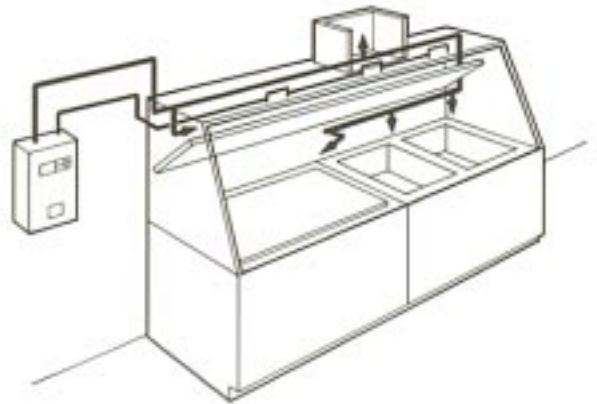

## Double Tank

3 gallon and 1.5 gallon  
16 flow point

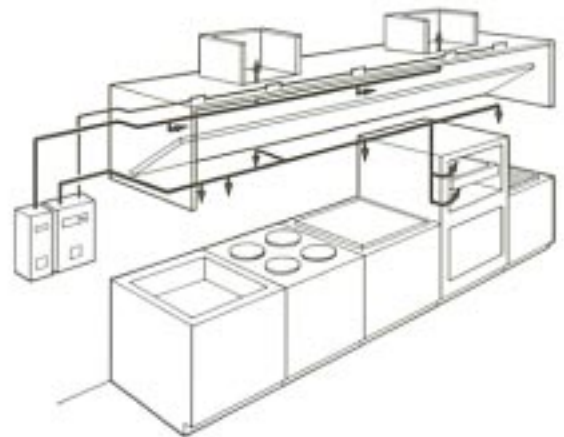

## Double Tank

6 gallon  
(two 3-gallon manifolded tanks)  
22 flow point

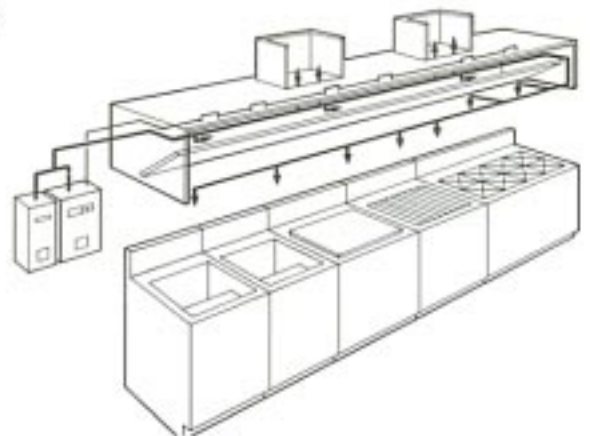

**Listings and Approvals.** The Ansul R-102 System hardware has been subjected to the rigorous Underwriters Laboratories Inc. UL-300 test standards and carries the UL listing for pre-engineered restaurant fire suppression systems. In addition, the R-102 System is also listed by Underwriters' Laboratories Inc. of Canada and carries New York City Board of Standards and Appeals approval under Materials and Equipment Acceptance (MEA) No. 59-95-E.

Typical Applications	Description of Protected Areas	Number of Nozzles	Basic Components	Accessory Devices
3 gallon single tank system designed to provide fire protection for the small kitchen appliance arrangement with a backshelf hood using low proximity nozzles 13 to 16 in. (.33-.41 m) away from hazard	<b>One</b> 75 in. (1.9 m) perimeter duct	One	<b>One</b> 3 gallon agent tank and releasing device <b>Three</b> fusible link detectors <b>Five</b> agent distribution nozzles <b>One</b> remote manual pull actuation device	<b>One</b> mechanical gas shutoff valve
	<b>One</b> 8 ft. (2.4 m) low profile hood	One		
	<b>One</b> 48 in. x 30 in. (1.21 x .76 m) griddle	One		
	<b>Two</b> 18 in. x 18 in. (.46 x .46 m) fryers	Two		
3 gallon and 1.5 gallon non-manifolded system designed to provide fire protection for the medium-sized kitchen appliance arrangement	<b>Two</b> 75 in. (1.9 m) perimeter ducts	Two	<b>One</b> 3 gallon agent tank and releasing device <b>One</b> 3 gallon add-on agent tank <b>Five</b> fusible link detectors <b>Eleven</b> distribution nozzles <b>One</b> remote manual pull actuation device	<b>One</b> electrical gas shutoff valve and controls
	<b>One</b> 16 ft. (4.9 m) hood	Two		
	<b>One</b> 20 in. x 20 in. (.51 x .51 m) fryer	Two		
	<b>One</b> 24 in. x 28 in. (.61 x .76 m) range	One		
	<b>One</b> 48 in. x 30 in. (1.22 x .76 m) griddle	One		
	<b>One</b> 32 1/2 in. x 30 in. (.83 x .76 m) upright broiler	Two		
	<b>One</b> 24 in. x 22 in. (.61 x .56 m) gas radiant charbroiler	One		
6 gallon manifolded system designed to provide fire protection for the large-sized kitchen appliance arrangement	<b>Two</b> 102 in. (2.6 m) perimeter ducts	Four	<b>One</b> 3 gallon tank and releasing device <b>One</b> 3 gallon tank <b>Six</b> fusible link detectors <b>Fourteen</b> distribution nozzles <b>One</b> remote manual pull actuation device	<b>One</b> mechanical gas shutoff valve
	<b>One</b> 21 ft. (6.4 m) hood	Three		
	<b>Two</b> 19 1/2 in. x 25 3/8 in. (.50 x .64 m) fryers	Two		
	<b>One</b> 36 in. x 30 in. (.91 x .76 m) griddle	One		
	<b>One</b> 26 in. x 24 in. (.66 x .61 m) lava rock charbroiler	Two		
	<b>One</b> 48 in. x 28 in. (1.22 x .71 m) range	Two		

**NOTES:** Other R-102 system size combinations up to 30 gallons are available to provide fire protection for larger kitchen appliance arrangements. Nozzle coverage for other appliances is available such as chain, lava rock, charcoal, mesquite broilers, and woks. Other accessories such as hood sealing adaptors, electric alarms, shutoff switches and devices are available.

## Call your nearby Ansul Restaurant Systems distributor...

They can help you analyze your fire protection needs, design the right system, install it, and provide 24-hour service. And they're only a phone call away. Check the Ansul listing in your Yellow Pages under "Fire Extinguishers..." or call toll-free 1-800-TO-ANSUL.

### Ansul. Experts in Global Fire Solutions.

RED LINE Fire Equipment • SENTRY Fire Extinguishers • AUTOPULSE Detection and Control Systems • Ansul R-102 Restaurant Systems with ANSULEX Low pH Liquid Fire Suppressant • Ansul Carbon Dioxide, Foam, Dry Chemical and INERGEN Systems • ANSULITE "Class B" Foam Concentrates • SILV-EX "Class A" Foam Concentrate • Ansul Dry Chemical and Dry Powder Extinguishing Agents • SPILL-X Spill Control Agents and Applicators

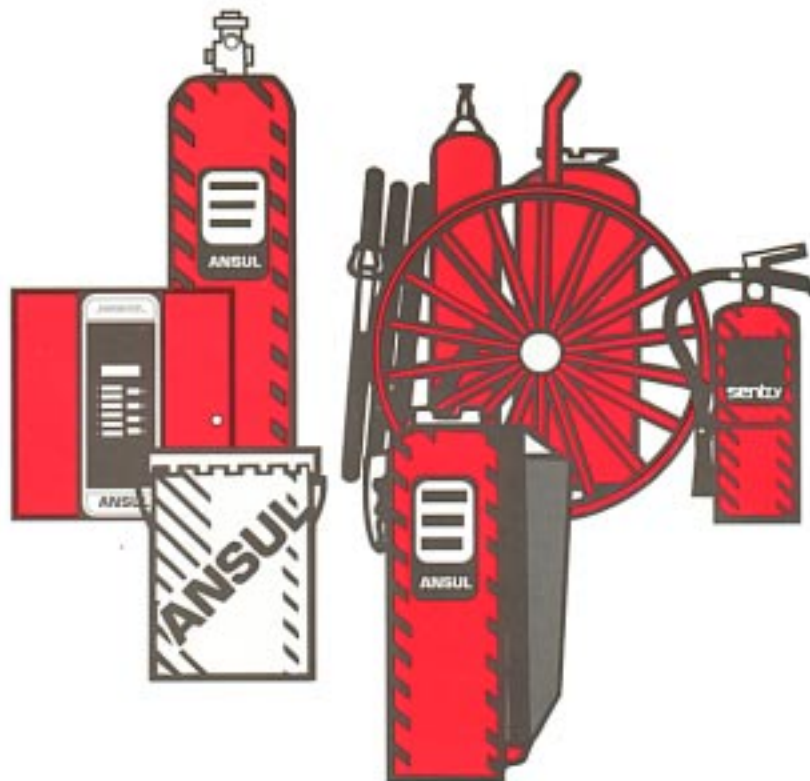

Your Authorized Ansul Distributor: