

Installation, Operation and Maintenance Instructions **for MAKE-UP AIR UNITS** **with Indirect Fired Gas Heat Option**



WARNING:

Improper installation, adjustment, alteration, service or maintenance can cause property damage, injury or death. Read the installation, operating, and maintenance instructions thoroughly before installing or servicing this equipment.

To prevent premature heat exchanger failure, do not locate any gas-fired units in areas where chlorinated, halogenated, or acid vapors are present in the atmosphere.

This unit is designed to incorporate a pre-manufactured indirect gas fired furnace. Read the manufacturer's manual for the furnace and this manual thoroughly before attempting any maintenance, start-up, or installation of this unit.

- ***If the unit has the Evaporative Cooling Option see the manual Part # 456858.***
- ***If the unit has the DX or Chilled Water Cooling Option see the manual Part # 457046.***

This manual is the property of the owner, and is required for future maintenance. Please leave it with the owner when you complete the job.



GREENHECK

P.O. BOX 410 SCHOFIELD, WISCONSIN 54476-0410
PH. 715-359-6171

Receiving and Handling

Upon receiving the equipment, check for both obvious and hidden damage. If damage is found, record all necessary information on the bill of lading and file a claim with the final carrier. Check to be sure that all parts of the shipment, including accessories, are accounted for.

Warranty

Greenheck warrants this equipment to be free from defects in material and workmanship for a period of one year from the purchase date. Any units or parts which prove to be defective during the warranty period will be repaired or replaced at our option. The motor is warranted by the motor manufacturer for a period of one year. Should the motor prove defective during this period, it should be returned to an authorized motor service station.

Greenheck will not be responsible for any installation or removal costs.

Due to continuing research, Greenheck reserves the right to change specifications without notice.

Table of Contents

Installation	3-7
100% Outside Air Units	
- Down Discharge	3
- Horizontal Discharge	4
- Combination Extension	5-6
Recirculation Air Units	7
Electrical	8-9
Supply Blower.....	10-12
- Start Up	10
- Trouble Shooting.....	11
- Maintenance.....	12
Furnace Section	13-17
- Gas Supply Pressure Requirements	13
- Maintenance.....	13
- Trouble Shooting.....	14
- Sequence of Operation	15
- Stage Control Settings.....	15
- Gas Control Layout.....	16
- High/Low Fire Settings	17
Dimensions	18-27
- Curbs/Combination Extension/Weights	18
100% Outside Air/Recirculation Air	
- With DownTurn Plenum.....	19-21
- With Horizontal Discharge	22-24
100% Outside Air w/Combination Extension	25-27
Documentation.....	28

Installation with Down Discharge

Before beginning this installation:

Make sure that there is room to access the unit from all sides. The inlet must be located at least 10 feet away from any exhaust vents.

This unit has a 6" clearance tolerance from the rear and a 24" clearance tolerance from the sides to any combustibles. A 48" clearance on the burner control side is recommended for service and removal of the burner.

Units are for outdoor installation only!

Step 1 Roof Opening

Determine the location of the supply duct roof opening. See pgs 19-21 for the recommended roof opening dimensions. These sizes can be smaller based on codes and ductwork sizes.

Step 2 Install Roof Curb and Optional Equipment Support

Center curb on 3 sides of roof opening, as shown in installation diagram. Level the curb and shim if necessary. Attach curb to roof and flash in place.

NOTE: An equipment support is required under the cooling/filter section if the unit has cooling. See submittals or consult factory for placement of support.

Step 3 Install Ductwork

The chart above shows the duct sizes recommended. Good duct practices should be followed for the remaining ductwork. The use of a duct adaptor with the supply duct is strongly recommended to properly align the ductwork with the supply fan discharge. The duct adaptor is only a guide and is not intended to be used as support for the ductwork.

Recommended Supply Ductwork Sizes	
IG Size	Duct Size
100 to 300	18x30
400 to 1200	24x40

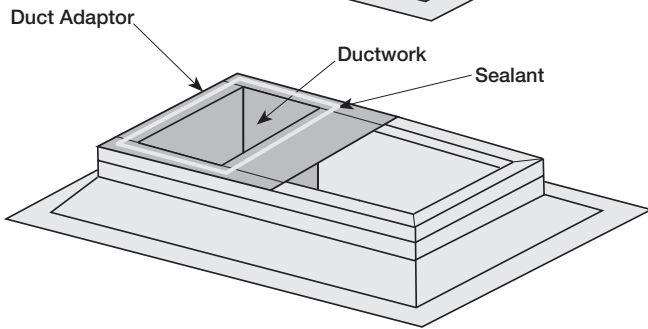
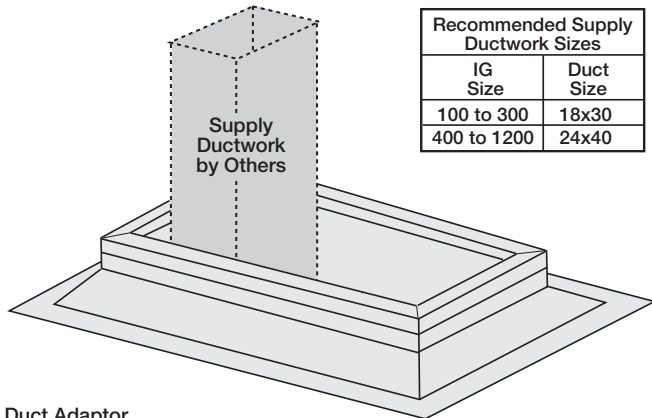

Step 4 Apply Sealant

Before installing fan, apply a sealant around the perimeter of the supply duct adaptor to isolate the fan and minimize vibration.

Step 5 Install Unit

Use a crane and a spreader bar hooked to the factory lifting lugs (as shown in the diagram) to lift and center the unit on the curb and equipment support.

NOTE: Use ALL lifting lugs on unit. Use self-tapping sheet metal screws to fasten unit to the curb and equipment support through holes provided.

Electrical and gas lines can be connected at this time.

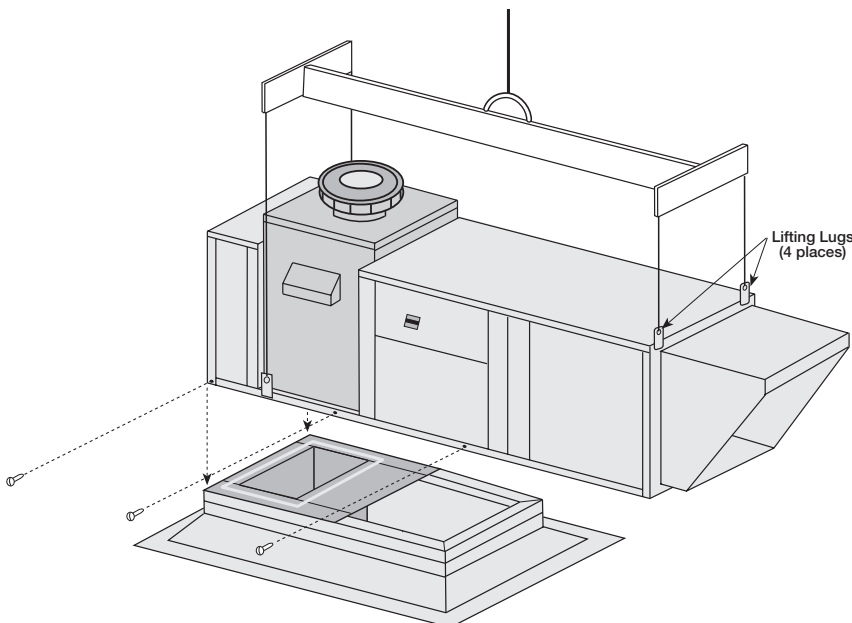

Installation with Horizontal Discharge

Before beginning this installation:

Make sure that there is room to access the unit from all sides. The inlet must be located at least 10 feet away from any exhaust vents.

This unit has a 6" clearance tolerance from the rear and a 24" clearance tolerance from the sides to any combustibles.

A 48" clearance on the burner control side is recommended for service and removal of the burner. **Units are for outdoor installation only!**

Step 1 Install Curb/Supports

See pgs 22-24 for curb dimensions. Unit may also be placed on equipment supports as long as they provide ample support for the unit.

NOTE: An equipment support is required under the cooling/filter section if the unit has cooling. See submittals or consult factory for placement of support.

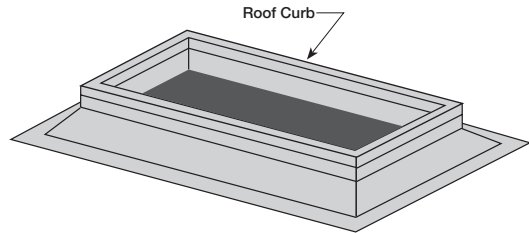

Step 2 Install Unit

Use a crane and spreader bar to lift unit onto equipment supports or curb. NOTE: Use ALL lifting lugs on unit. See pgs 22-24 for lifting lug locations.

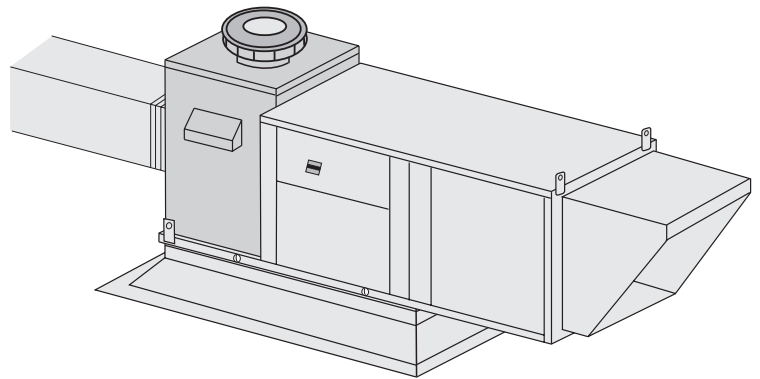

Step 3 Attach Ductwork to Unit Discharge

See pgs 22-24 for discharge dimensions. Greenheck recommends attaching ductwork to collar using a rubber duct section at the unit to eliminate vibration. Follow the furnace manufacturer's recommendation for proper ductwork methods for transitions after the unit.

Step 4 Mount Discharge Stat/Sensor

The discharge sensor will need to be mounted in the ductwork down stream of the unit. Make sure to note the airflow direction labeled on the mixing tube (elec mod only). Wiring from the duct stat to the amplifier must be in separate conduit or in shielded cable if being run with other power wires. See the wiring diagram provided with the unit. The duct stat should be

placed down stream where there is good air mixture and where it is away from dead spots in the ductwork. Sometimes this can only be done through trial and error. Too far from the unit may cause delay problems. The duct stat should be mounted where it is shielded from the weather (elec mod only).

Electronic Modulation

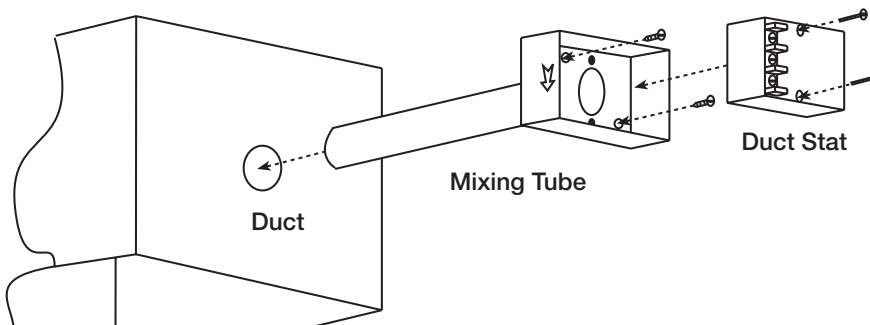

Stage Control

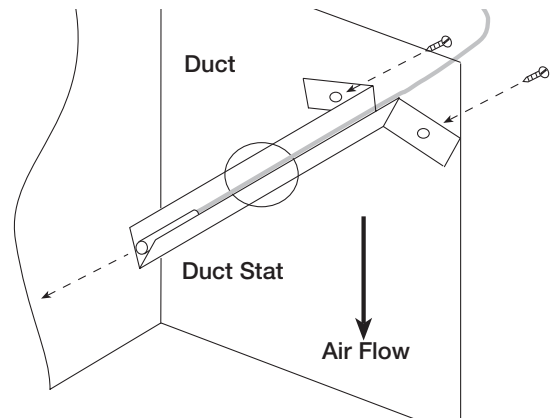

Installation with Optional Combination Extension

Before beginning this installation:

Make sure that there is room to access the unit from all sides. The inlet must be located at least 10 feet away from any exhaust vents.

This unit has a 6" clearance tolerance from the rear and a 24" clearance tolerance from the sides to any combustibles. A 48" clearance on the burner control side is recommended for service and removal of the burner.

Units are for outdoor installation only!

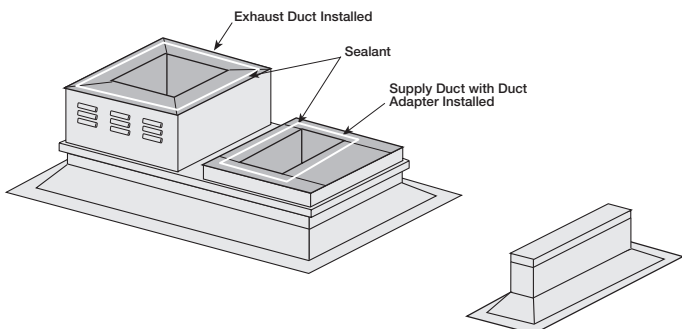
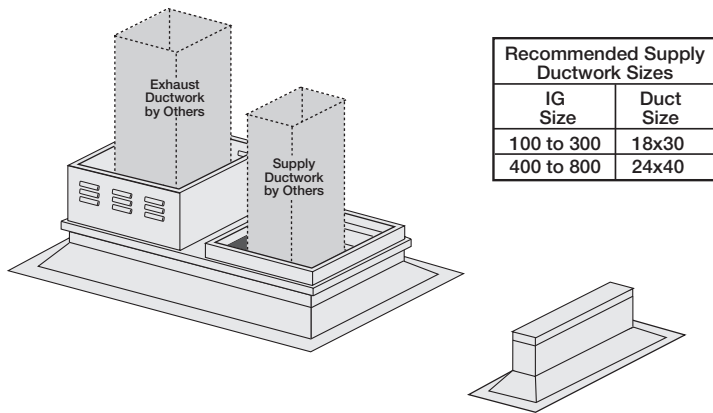
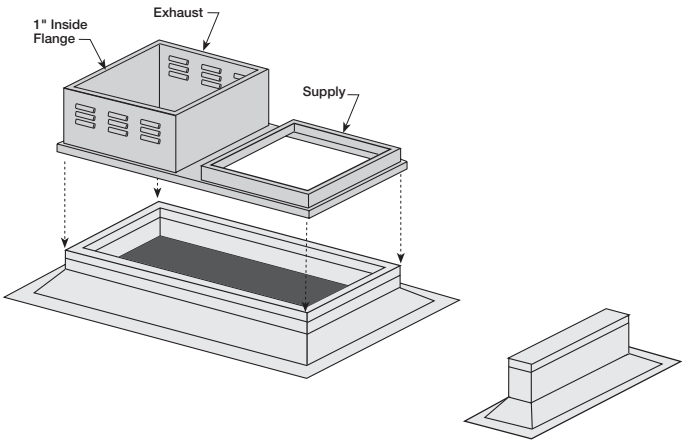
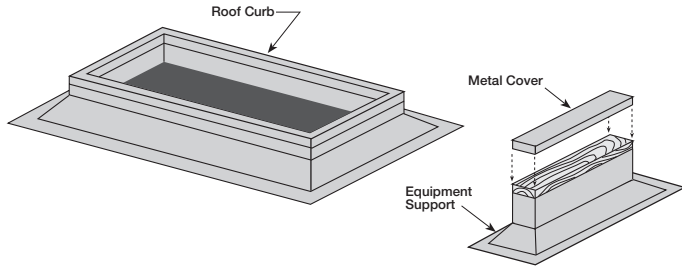

Step 1 Roof Opening

Determine the position of the exhaust and supply duct roof openings. See pgs. 25-27 for recommended roof opening dimensions. These sizes can be smaller based on codes and ductwork sizes.

Step 2 Install Roof Curb and Equipment Support

Center curb over roof openings and place on the roof. Level the curb and shim if necessary. Attach curb to roof and flash in place.

See pgs 25-27 for equipment support locations. Attach to roof in the same manner as the curb, remove metal cover, flash to wooden nailer and reinstall cover.

Step 3 Install Combination Extension

Install combination extension over curb, use wood screws to lag in place. Prepunched holes are provided. Locate extension so the tall louvered side is over the exhaust opening, as shown in illustration.

Step 4 Install Ductwork

Exhaust:

Exhaust ductwork must be built in accordance with NFPA 96 and any local codes. Ductwork terminating at the fan should be square in shape or of smooth transition so as not to affect the fan performance.

Supply:

The chart at left shows the duct sizes recommended. Good duct practices should be followed for the remaining ductwork.

The use of a duct adapter with the supply duct is strongly recommended to properly align the ductwork with the supply fan discharge. The duct adapter is only a guide and is not intended to be used as support for the ductwork.

Step 5 Apply Sealant

Before installing fans, apply a sealant around the perimeter of the exhaust and supply duct adapter to isolate the fan and minimize vibration.

Step 6 Install Exhaust Fan

Install CUBE exhaust fan on curb extension. Fasten with self-tapping sheet metal screws through existing holes in curb cap. NFPA 96 requires the exhaust fan be hinged.

Greenheck offers an optional hinge kit with restraining cables and a grease trap with drain connection. Install these options at this time.

NOTE: Installing the exhaust fan prior to the supply unit will allow for easier installation of options.

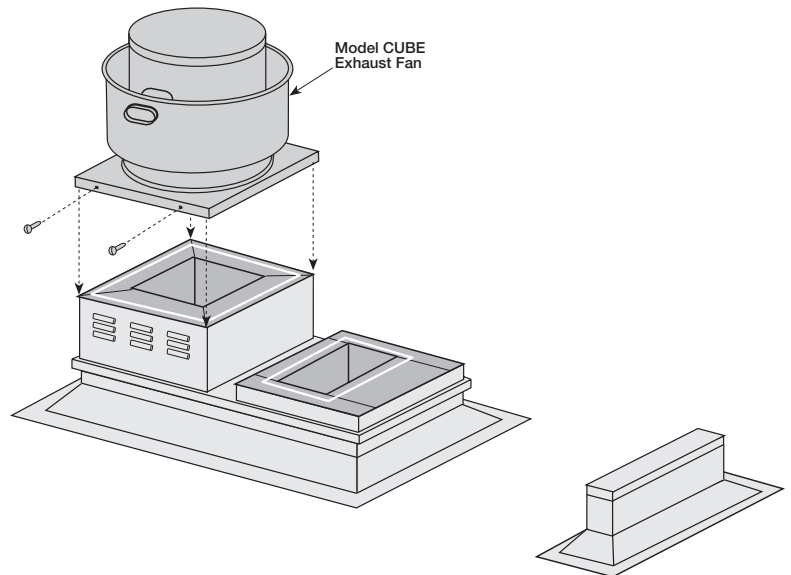

Step 7 Install Supply Unit

Use a crane and a spreader bar hooked to the factory lifting lugs (as shown in the diagram) to lift and center the unit on the curb and equipment support.

NOTE: Use ALL lifting lugs on unit. Use self-tapping sheet metal screws to fasten unit to the curb and equipment support through holes provided.

Electrical and gas lines can be connected at this time.

Use caution to avoid damaging exhaust fan when installing supply unit.

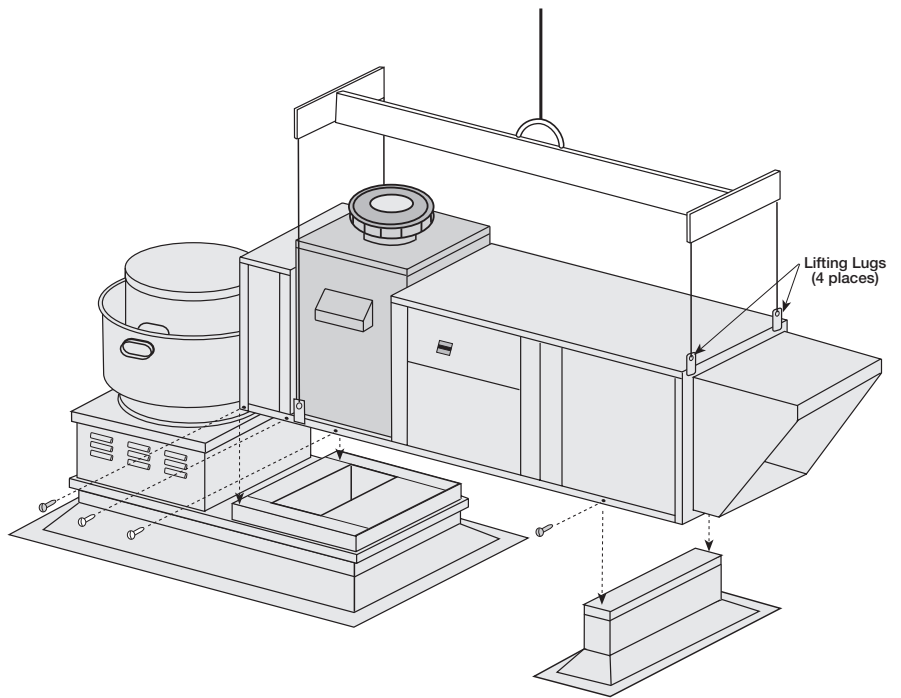

Complete Installation

Illustration shows the complete installation.

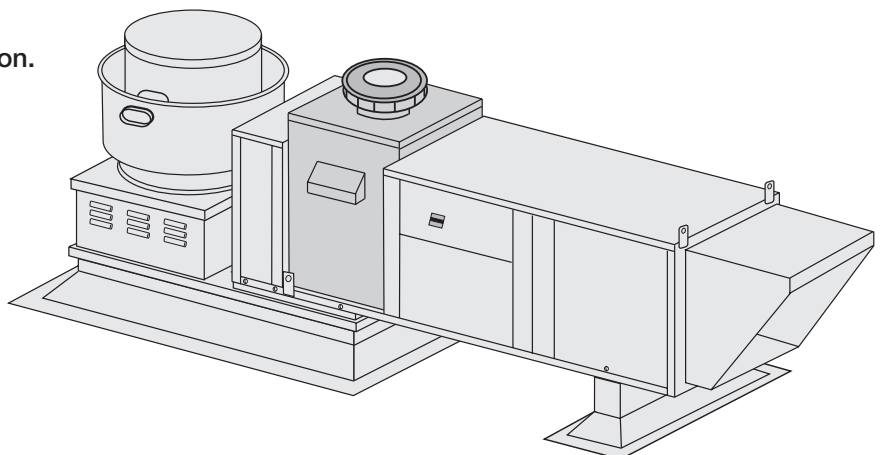

Installation with Recirculation Option

Before beginning this installation:

Make sure that there is room to access the unit from all sides. The inlet must be located at least 10 feet away from any exhaust vents.

This unit has a 6" clearance tolerance from the rear and a 24" clearance tolerance from the sides to any combustibles. A 48" clearance on the burner control side is recommended for service and removal of the burner.

Units are for outdoor installation only!

Step 1 Roof Openings

Determine the position of the supply and return duct roof openings. See pgs 19-24 for recommended roof opening dimensions. These sizes can be smaller based on codes and ductwork sizes.

Step 2 Install Roof Curb

Position curb over roof openings. Level the curb and shim if necessary. Attach curb to roof and flash in place.

Step 3 Install Ductwork

The chart below shows the duct sizes recommended. Good duct practices should be followed for the remaining ductwork.

The use of a duct adaptor is strongly recommended to properly align the ductwork with the supply fan discharge. The duct adaptor is only a guide and is not intended to be used as support for the ductwork.

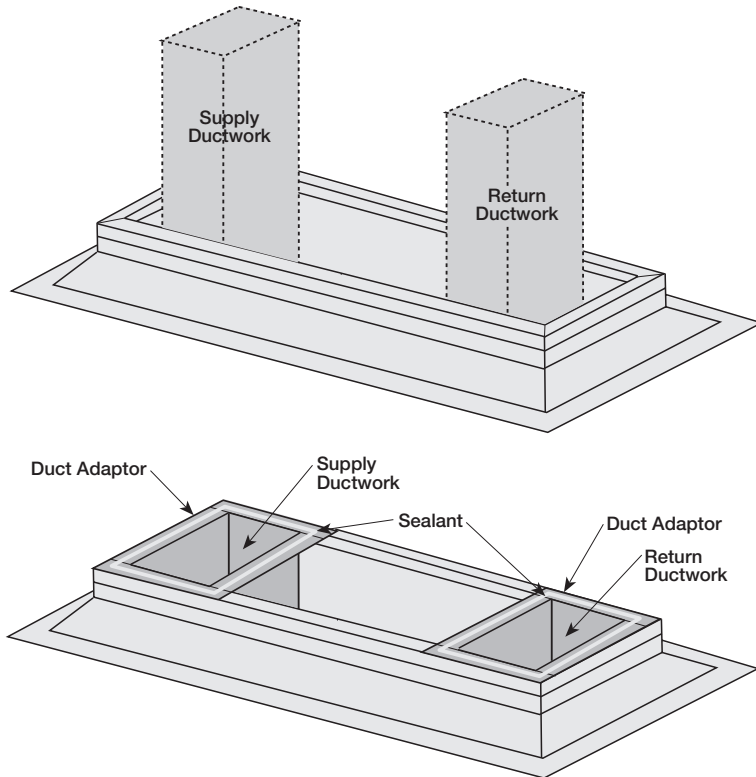

Recommended Ductwork Sizes		
IG Size	Supply Duct	Return Duct
100 to 300	18x30	17x30
400 to 1200	24x40	17x42

Step 4 Apply Sealant

Before installing fans, apply a sealant around the perimeter of the exhaust and supply duct adaptor to isolate the fan and minimize vibration.

Step 5 Install Unit

Use a crane and a spreader bar hooked to the factory lifting lugs (as shown in the diagram) to lift and center the unit on the curb and equipment support. **NOTE:** Use ALL lifting lugs on unit. Use self-tapping sheet metal screws to fasten unit to the curb and equipment support through holes provided.

Electrical and gas lines can be connected at this time.

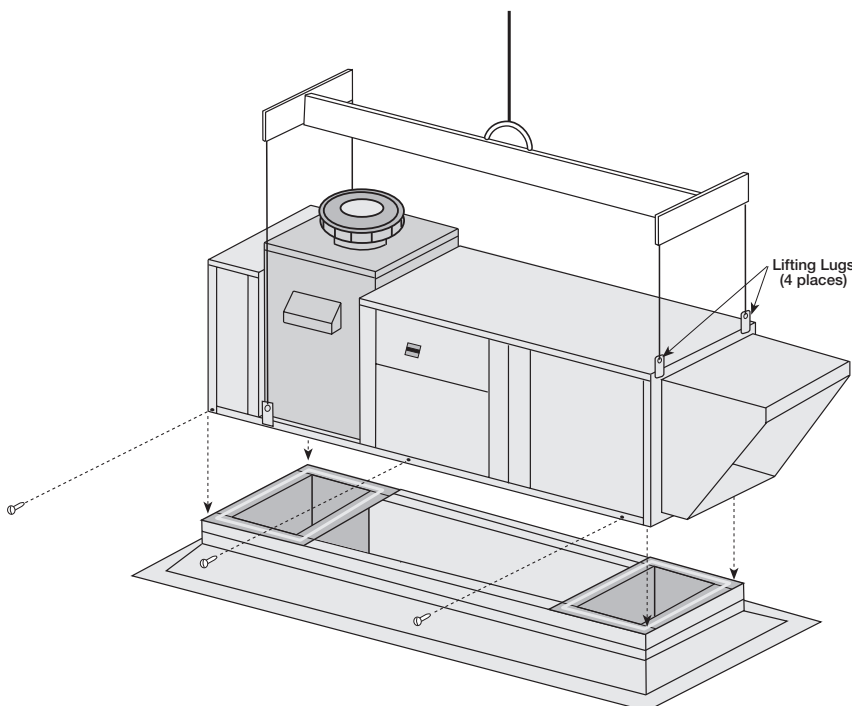

Electrical Instructions

Before connecting power to the unit, read and understand the following instructions and wiring diagrams. Complete wiring diagrams are attached inside the door(s) of the unit.

All wiring should be done in accordance with the National Electrical Code ANSI/NFPA-70 latest edition and any local codes that may apply. In Canada, wiring should be done in accordance with the Canadian Electrical Code. The equipment must be properly grounded.

DANGER !
High voltage electrical input is needed for this equipment. This work should be performed by a qualified electrician.

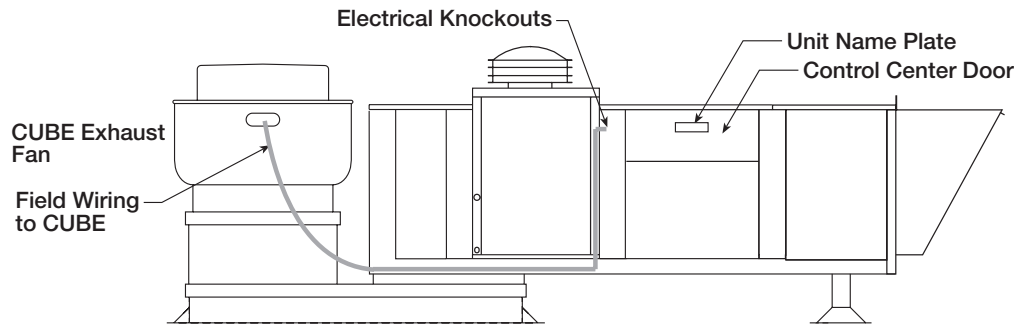

NOTE: Any wiring running through the unit in the airstream must be protected by flexible metal conduit, metal clad cable or raceways.

Notes for wiring units

For all units:

1. The units nameplate states the voltage and total amperage required.
The main feeder supplying power to the unit should be sized for the name plate voltage and amperage.
2. The main power line should be connected to the disconnect switch.
Make sure that the disconnect lugs are securely tightened.
3. Connect control panel wiring to terminal strip in the control center.
Greenheck's standard control voltage is 120/60/1.
4. Wire any remote temperature selectors (optional) at this time. These wires should be shielded cable if they are to be run with other power wires.
5. When an optional convenience outlet is provided, a separate power supply must be provided to the receptacle. This circuit must be on a ground fault breaker.

For power vent units:

1. Power vent units require an additional field supplied 115 Volt power source for the power vent motor.
2. The power vent unit is factory interlocked with the power to the furnace so the furnace will not function unless the power vent motor is running.
3. The power vent motor will not run unless the furnace is turned on and the gas controls are calling for heat.

For units with combination extension:

1. Wire power lead for CUBE through side breather tube.
2. The power lead should be of sufficient length as to allow the CUBE fan to hinge open and to allow service of the burner controls.

CAUTION !
Any wiring deviations may result in personal injury or property damage. Greenheck is not responsible for any damage to, or failure of the unit caused by incorrect field wiring.

Control Center Layout and Descriptions

The following picture is a typical 3 phase control center with an additional exhaust fan starter. This is for visual aid while working with the unit.

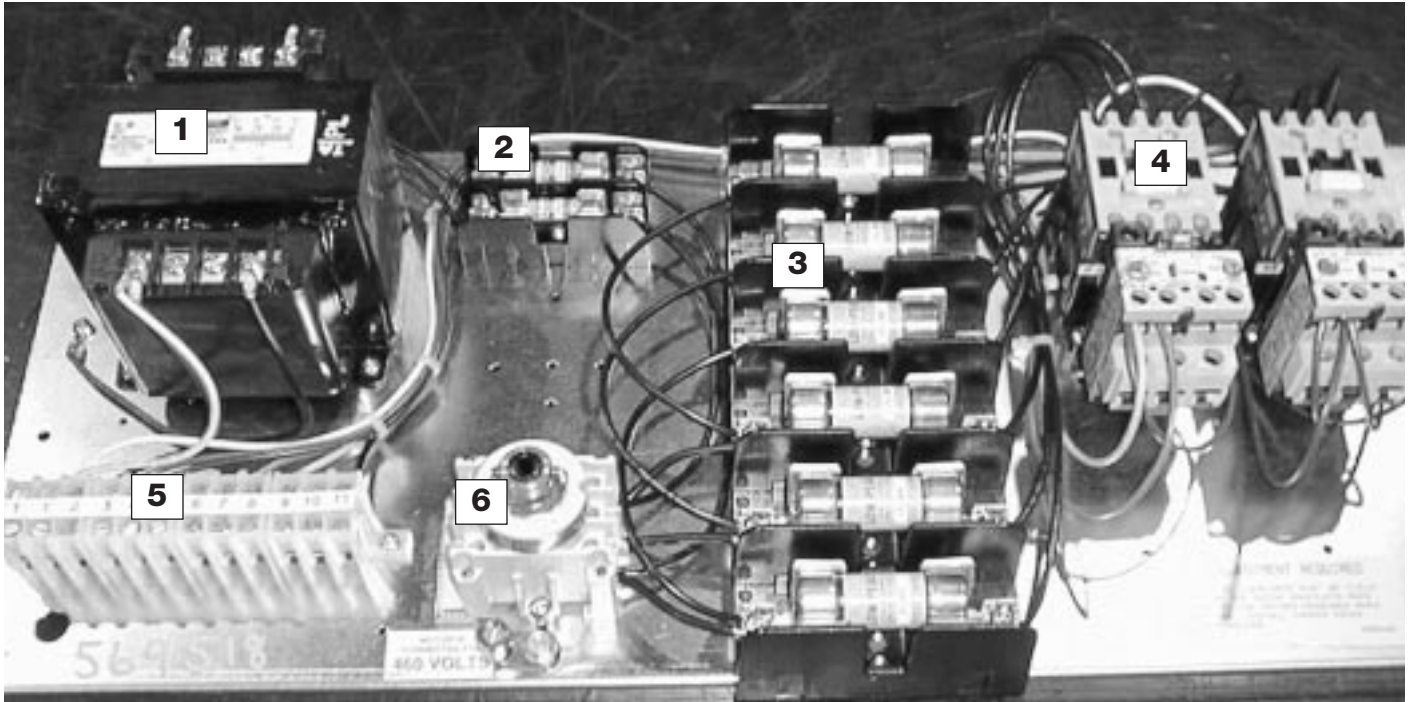

- 1. Control Transformer** - Provides 120 Volt for fan controls.
- 2. Transformer Fuses** - Provides proper fusing for control transformer.
- 3. Motor Fuses** - Provides proper fusing for supply and exhaust fan motor.
- 4. Motor Starters** - 120 Volt magnetic contacts for starting motors, comes standard with electronic overload. Can be provided with auxiliary contacts. Optional exhaust fan starter shown.
- 5. Terminal Strip** - 120 Volt power at strip for control wiring.
- 6. Master Disconnect** - Door interlock type disconnect comes standard with control center. Hook high voltage power leads to this point.

Note: This is a typical control center, an exact wiring diagram is shipped with the unit.

Supply Blower

Blower Start Up

For proper unit function and safety, follow everything in this startup procedure in the order presented. This to be done after the electrical and gas connections are complete.

Special Tools Required

- Voltage meter
- Tachometer
- Amperage meter

1. Check Voltage

Before starting the unit, compare the supplied voltage with the units nameplate voltage and the motor voltage.

2. Check Blower Rotation

If the blower is rotating in the wrong direction, the unit will move some air but not perform properly.

To check the rotation, open the blower access door and run the blower momentarily to determine the rotation.

To reverse the rotation, turn the power off and use the following procedure:

- For single phase units, rewire the motor per the instructions on the motor.
- For three phase units, interchange any two power leads. This can be done at the motor starter.

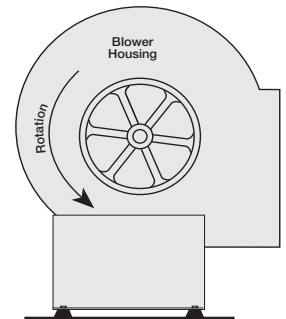

3. Air Volume Check and Measurement

Along with the building balance, the units air volume (cfm) should be measured and compared with its rated air volume. This unit is flexible for varying air volume, but the actual air volume should be known for making final adjustments.

The most accurate way to measure the air volume is by using the pitot traverse method in the ductwork away from the blower. Other methods can be used but should be proven and accurate. To adjust the air volume, change the fan rpm or the system static. See Trouble Shooting section in this guide.

4. Measure Motor Voltage, Amperage and Fan RPM

All access doors must be installed except the control center door and gas control door. Measure and record the input voltage and motor amperage(s).

To measure the fan rpm, the blower door will need to be removed. Minimize measurement time because the motor may over amp with the door removed.

Compare measured amps to the motor nameplate full load amps and correct if over amping. See the Trouble Shooting section in this guide.

5. Settings for Optional Components

Optional Freeze Protection:

This shuts down the blower if the output temperature is below the set point. A timer allows the blower to operate during startup. This will reset when turned off.

Typical settings are: Discharge temperature = 45°F Timer = 5 minutes

Optional 2 Hour Time Delay:

This allows the unit to operate for up to 2 hours (1 to 120 min) after the control panel switch has been turned off. The timer has an adjustment knob on it.

Optional Inlet Air Sensor:

This shuts down the heater if the incoming air temperature is higher than the set point. This switch will automatically reset as temperature decreases. A typical setting is 60°F.

Blower Trouble Shooting

The following is a cause and correction list for common problems with the blower unit. Also see furnace section and the furnace manual for troubleshooting the furnace section of the unit.

Symptom	Possible Cause	Corrective Action
Blower fails to operate	Blown fuse or open circuit breaker	Replace fuse or reset circuit breaker and check amps
	Broken fan belt	Replace
	Defective motor or capacitor	Replace
	Motor starter overloaded	Reset starter and check amps
Motor over amps	cfm too high	Check cfm and adjust drives if needed
	Static pressures are higher or lower than design	If higher, ductwork should be improved If lower, fan rpm should be lower
	Blower rotation is incorrect	Check rotation and correct
	Motor voltage incorrect	Check motor nameplate and supplied voltage
	Motor horsepower too low	See specifications and catalog for fan curves to determine if horsepower is sufficient
	Shorted windings in motor	Replace motor
Insufficient airflow	Unit damper not fully open	Adjust damper linkage or replace damper motor
	System static pressure too high	Improve ductwork to eliminate losses using good duct practices
	Blower speed too low	Check for correct drives and rpm with catalog data
	Dampers or registers closed	Open and adjust
	Dirty or clogged filters	Clean or replace
	Leaks in ductwork	Repair
	Elbows or other obstructions may restrict fan outlet	Correct or improve ductwork
	Belt slippage	Adjust belt tension
Too much airflow	Blower fan speed too high	Check for correct fan rpm
	Filter(s) not in place	Install filters
	Insufficient static pressure (SP) (airflow resistance)	Induce SP into system ductwork.
Excessive noise or vibration	Wheel rubbing on housing	Center wheel
	Loose wheel on shaft	Tighten wheel setscrew
	Loose motor or blower sheave	Tighten sheave setscrew
	Belts too loose	Adjust belt tension after 24 hours of operation
	Belts too tight	Loosen to maintain 3/8" deflection per ft. of span between sheaves
	Worn belt	Replace
	Motor base or blower loose	Tighten mountings bolts
	Worn bearings	Replace
	Bearing and drive alignment	Realign
	Motor out of balance	Replace
	Wheel out of balance	Replace or rebalance
	Sheaves eccentric or out of balance	Replace or rebalance
Accumulation of material on wheel	Clean wheel and housing	

Blower Maintenance

Greenheck recommends these procedures to insure trouble free operation of this unit. See the furnace portion of this manual and the furnace manual for maintenance of the furnace section.

A record of maintenance performed on this unit should be kept. This information will provide essential information if problems are encountered. A section at the back of this manual is provided for recording the units maintenance history.

CAUTION: When performing any maintenance on this unit, be sure that the power is disconnected and cannot be accidentally turned on. The control center disconnect can be locked in the off position .

2 weeks after startup

Check belt tension - Belts tend to stretch after a period of time. They should be periodically checked for wear and tightness.

Approximately 3/8" of deflection per ft. of span between sheaves is standard for belt tightness. When replacing belts, use the same type as supplied with the unit. Matched belts should always be used on units with multi groove pulleys.

Replacement of belts - should be accomplished by loosening the tensioning device to the point where the belts can be removed by hand. Do not force belts on or off as this may cause breakage of cords leading to premature belt failure. Belts should be adjusted as above.

Every 3 Months

The filter in the unit should be inspected at least every 3 months. Depending on the environment filters could require changing or cleaning more or less often. The filters can be slid out of either side of the unit.

If **washable filters** are installed, they can be washed in warm soapy water. An adhesive spray can be applied to increase filter efficiency.

If **disposable filters** are installed, check by holding up to a light source. If light cannot pass through the filter, it should be replaced. Replacement filters should be of the same manufacturer and size.

When reinstalling filters be sure to install with the airflow in the correct direction indicated on the filter and with any factory spacers that came with the unit.

Yearly

All **bearings** are factory lubricated and require no further lubrication under normal use. Normal use being considered -20°F to 180°F and in a relatively clean environment.

Motor maintenance is generally limited to cleaning and lubrication (where applicable). Cleaning should be limited to the exterior surfaces only. Removing dust and grease buildup on motor housing assures proper motor cooling. Greasing of motors is intended only when grease fittings are provided. Many fractional motors are permanently lubricated and require no further lubrication. Motors supplied with grease fittings should be greased in accordance with manufacturer's recommendations. When motor temperature does not exceed 104°F (40°C), the grease should be replaced after 2000 hours of running time as a general rule.

Wheels require very little attention when moving clean air. Occasionally oil and dust may accumulate on the wheel causing imbalance. When this occurs the wheel and housing should be cleaned to assure smooth and safe operation.

Routinely check all **fasteners** for tightness.

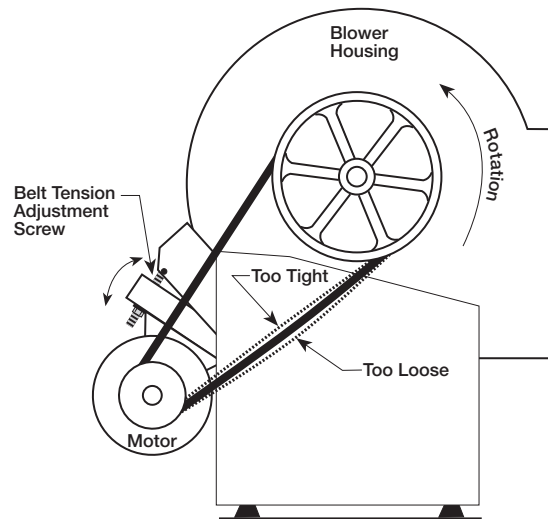

Furnace Section

Important !!

This section of the manual is only to supplement the furnace manufacturers manual. You must thoroughly read this manual and the furnace manufacturer's manual before doing any installation, operation, or maintenance of the make-up air unit.

WARNING !!

If You Smell Gas:

1. Open all Windows.
2. Don't touch electrical switches.
3. Extinguish any open flame.
4. Immediately call your gas supplier.

For Your Safety!!

The use and storage of gasoline and other flammable vapors and liquids in the vicinity of this appliance is hazardous.

Gas Supply Pressure Requirements

All furnace sizes require the same amount of gas supply pressure. Single furnaces (furnace input 100 to 400 MBH) have a single 3/4" connection, double furnaces (furnace input 500 to 800) have two 3/4" connections, and triple furnaces (furnace input 1050 to 1200) have three 3/4" connections.

Natural: 6 to 14 in. wg

LP: 11 to 14 in. wg

For input rates see the furnace manufacturer's recommendations.

Furnace Maintenance

The following procedure should be completed before every heating season by a qualified service person.

1. Remove and inspect burner. Check burner ports and burner mixing tubes for cleanliness. Also inspect pilot assembly.
2. While the burner is removed, use a mirror and flashlight to look at bottom of heat exchanger and inside heat exchanger tubes. Check for any signs of corrosion, cracks, or soot. Also, inspect outside of heat exchanger for any cracks or signs of overheating.
3. Inspect main burner gas orifices in gas manifold to make sure they are not blocked with spider webs. Use a toothpick for cleaning if necessary. Also remove and inspect pilot orifice. If dirty or damaged clean or replace.
4. Check combustion air openings and vent system. Clear of any debris.
5. Run unit and check general operations.
6. Inspect pilot and main burner flames. Observe burner flames to ensure that they are burning straight and clean and there are well defined inner cones. If an abnormal flame is observed, check furnace manufacturer's manual for proper adjustments.
7. Check for correct blower rpm.
8. Check high and low manifold pressures.

Trouble Shooting Intermittent Pilot Systems

Procedure for trouble shooting furnace when main burner does not light on a call for heat.

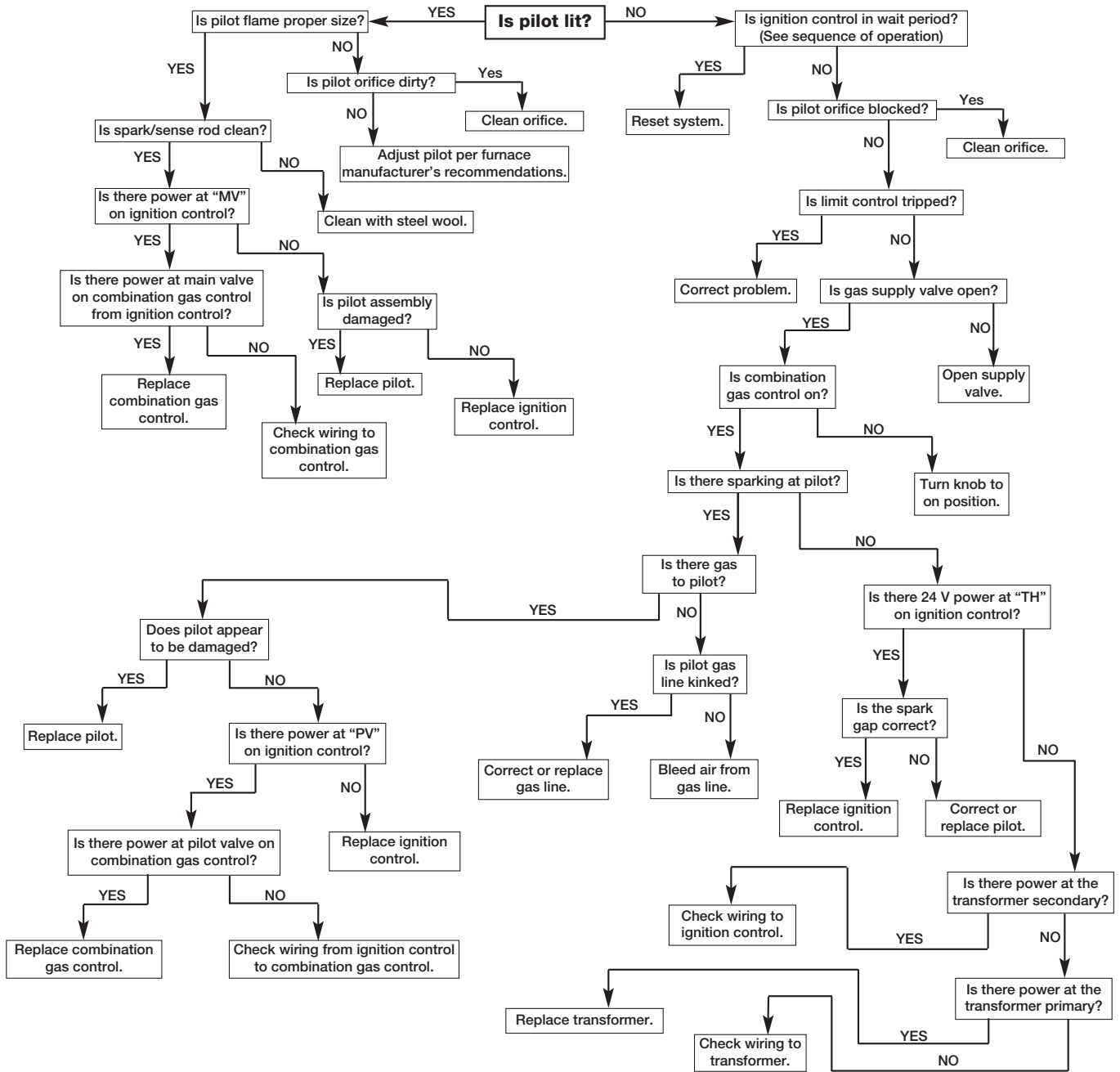

**For additional trouble shooting recommendations please consult the furnace manufacturers installation and operation manual.

Sequence of Operation

Control Center

1. Turn the fan switch to the “on” position (If summer/off/winter switch is used, turn to “winter” position).
2. Damper actuator is energized (Optional).
3. Supply Starter is energized. Supply fan runs. If an exhaust fan is included, it must run before the supply fan.
4. Turn the heater switch “on” (if using a separate switch from fan).
 - If an off delay timer is included (1 to 120 minutes), the fan will continue to run after the switch is turned off.
 - If freeze protection is included, a timer (1 to 5 minutes) and a discharge temperature sensor are included. The unit must heat up to the discharge sensor’s setting before the timer runs out or the supply fan will shut down.

Heater

5. Open all manual gas valves.
6. High temperature limit is normally closed (automatic reset).
7. Optional inlet air sensor contact is closed (normally open).
8. If the temp control system senses that the discharge temperature is below the set point of the temperature selector, the system will energize the ignition control.

Note: If the discharge is above the set point, the heater will not run.
9. When the ignition control is energized, sparking will start at the pilot. At the same time the first operator (pilot gas) of the gas valve allows gas to flow to the pilot burner. In a few seconds the pilot should be established and proven. This will stop the sparking and open the second operator (main gas) of the gas valve, allowing gas to flow to the main burner.

Natural Gas - If the pilot is not established and proven after 70 seconds, the ignition controller will pause for 5 minutes with the gas valve closed and no spark and restart the ignition sequence again. After going through this trial/wait sequence 3 times, the control will wait an additional 1 hour and repeat the process again (if necessary).

LP Gas - If the pilot is not established and proven after 70 seconds, the ignition control will lockout. The pilot gas valve will close and sparking will stop. The system will not attempt to light until the power to the heater is turned off and back on.

- 10A. Elect Mod: The maxitrol system will then modulate the main burner gas from 100% down to 40% as needed. If the burner remains on low fire for an short amount of time, the heater will be shut off and restarted as necessary.
- 10B. Staged: The stage control will energize the stages as necessary to maintain the discharge setting or satisfy the room thermostat. For example a 3 stage discharge control with two furnaces will fire the first furnace at 50% (stage 1) when there is a call for heat. If the discharge setting is not satisfied, the first furnace will then fire at 100% (stage 2). If still not satisfied, the second furnace will also fire at 100% (stage 3). When the discharge temperature approaches the set point, the stages de-energize in reverse order. The first stage will stay on until the discharge temperature is reached.

Settings for Staged Discharge Temperature Controls

Typical 4-Stage Discharge Temperature Control

The furnace stage controls are located in the control center. For units with room thermostats these controls are not included. They are modular controls that plug into each other. The discharge temperature setting is located on the control furthest left. The stage differential settings are preset at the factory and should not need adjustment. See the literature provided with the controls for further information.



Gas Control Layout

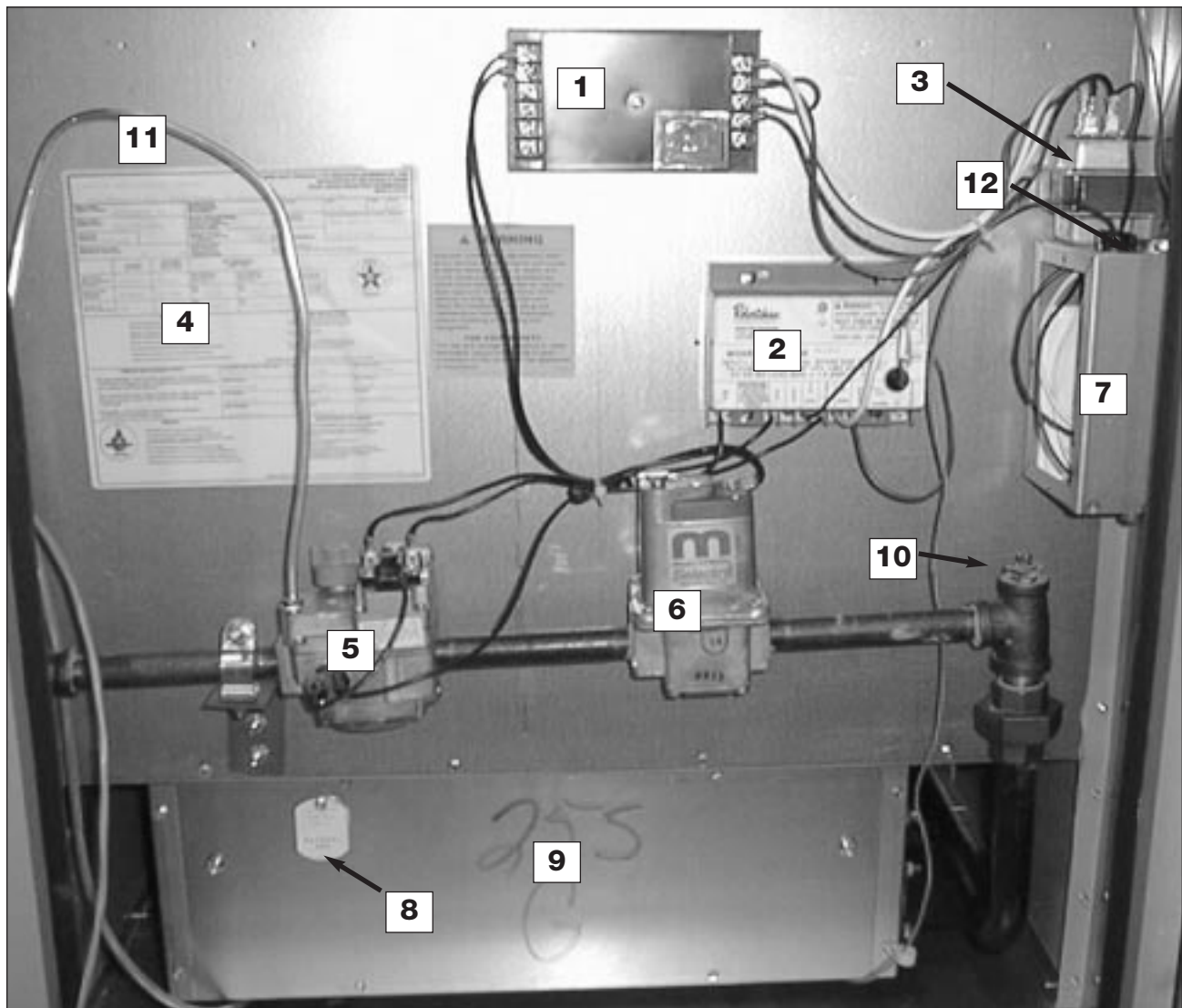

1. **Amplifier** - Converts the signal from the discharge air stat to a working voltage to control the modulating gas valve. (Electronic Modulation Only)
2. **Ignition Control** - Controls pilot and burner ignition and flame safe guard operation.
3. **24V Transformer** - Transforms 120V control voltage to 24V control voltage for gas controls.
4. **Serial Plate** - This contains important information about the furnace. If looking for replacement parts from the manufacturer, this has part numbers you will need to order the correct parts.
5. **Combination Gas Control Valve** - This valve contains main pressure regulator, safety shut off valves, pilot regulator, and manual shut off knob. For staged control this valve also controls 50% and/or 100% fire.
6. **Modulating Valve** - Modulates gas to main burner for proper furnace discharge temperature. (Electronic Modulation Only)
7. **Power Junction Box** - 120V Power is connected here from control center by factory.
8. **Gas Designation Disk** - Slide to the side to view proper pilot establishment.
9. **Burner Slide Out Tray** - Burner slides out for ease of service.
10. **Manifold Pressure Test Port** - For testing of proper gas pressures.
11. **Pilot Gas Line**
12. **High Temperature Limit Switch** - Protects furnace from overheating. Auto reset device.

When servicing, repairing or replacing parts on these units, always give the complete model number, serial number, and replacement part numbers from the units serial plate.

Setting High and Low Gas Pressure

Maxitrol Modulating Valve

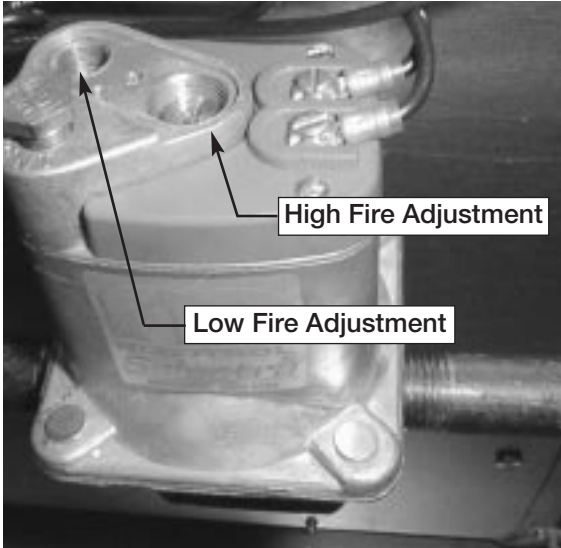

Picture shown with cover plate removed.

High and Low Fire Settings for Electronic Modulation:

Check the high and low gas pressures on initial start up. These settings are pre-set at the factory, but should be adjusted in the field if necessary. Set the high fire first and the low fire second. The low fire must always be checked if the high fire is changed.

1. Set the unit to high fire by removing the wire from terminal 3 on the Maxitrol amplifier. Make sure that this wire is isolated after removing.
2. Measure the burner manifold pressure for each furnace at the pressure test port (see page 16) using a high quality manometer that can measure low gas pressures. The pressure should be 3.5 in. wg for natural gas and 10.0 in. wg for LP Gas. To change the pressure, adjust the high fire screw on the modulating valve. If the high fire screw is at the end of its adjustment and more pressure is needed, then adjust the main pressure regulator on the combination gas control valve. It is located under the cap screw indicated in the lower left hand picture.

Combination Gas Control Valve (Typical)

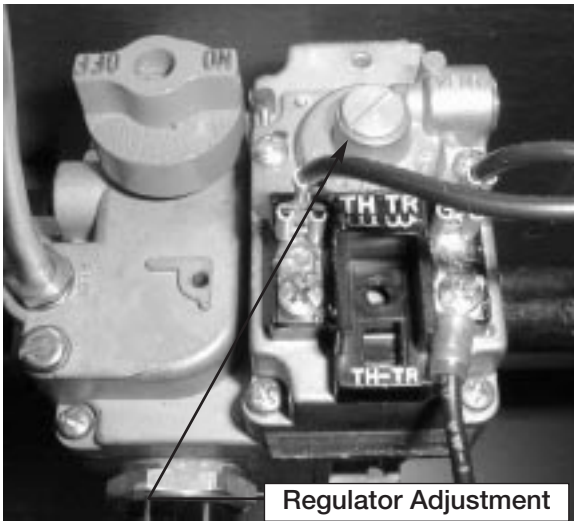

3. Reconnect wire to terminal 3.
4. To get the unit to low fire: On the Maxitrol amplifier, move the wire from terminal 11 to terminal 10. Set the discharge temperature selector to the lowest setting. If the outside air is below 55° F, place a jumper wire from terminal 3 to terminal 4 on the amplifier. If there is a room override stat, remove the wire from terminal 14 on the amplifier and isolate this wire.
5. Measure the manifold pressure on low fire, it should be .56 in. wg for natural gas and 1.6 in. wg for LP gas.
6. To Adjust the low fire, adjust the screw indicated in the top right hand picture on the modulating valve.
7. Place all wires back to where they were and plug the manifold pressure port.

High Fire Setting for Staged Control

Check the high gas pressure on initial start up. This setting is pre-set at the factory, but should be adjusted in the field if necessary. The low fire setting (if it is a two stage valve) is fixed.

1. Set the unit to high fire by setting the discharge control or thermostat to the maximum setting. If the ambient temperature is warm the unit may not stay at high fire. Please consult the factory if you have problems getting the unit to stay on high fire.
2. Measure the burner manifold pressure for each furnace at the pressure test port (see page 16) using a high quality manometer that can measure low gas pressures. The pressure should be 3.5 in. wg for natural gas and 10.0 in. wg for LP Gas. To change the pressure, adjust the regulator adjustment screw on the combination valve.

Dimensional Information

Curbs and Equipment Support

Note: For use with a fan package extension the equipment support must be 4" taller than the curb.

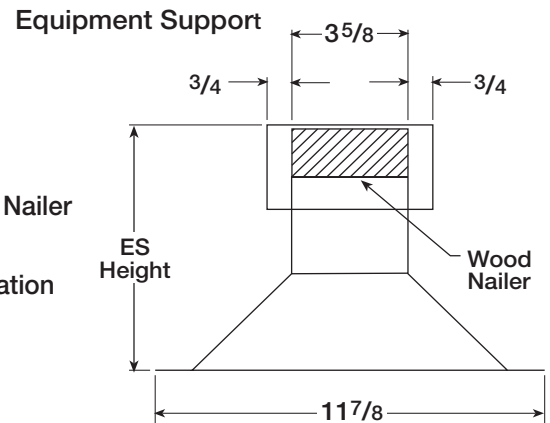
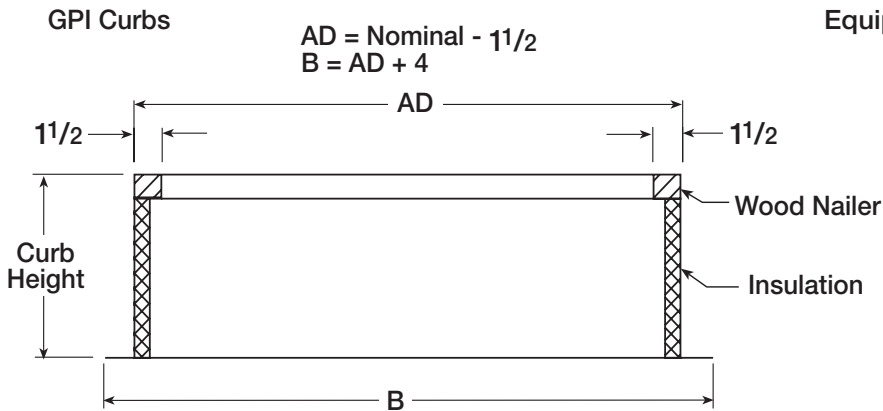

Nominal Curb Size Selection Chart

IG Size	100% OSA w/DB Discharge	100% OSA w/HZ Discharge	Recirculation w/DB Discharge	Recirculation w/HZ Discharge	w/Combination Extension
100 to 300	40 x 90	40 x 69	40 x 120	40 x 98	40 x 88
400	52 x 108	52 x 79	52 x 136	52 x 108	52 x 98
500 to 800	52 x 142	52 x 114	52 x 170	52 x 142	52 x 98
1050 to 1200	52 x 178	52 x 149	52 x 206	52 x 178	52 x 98

Combination Extension

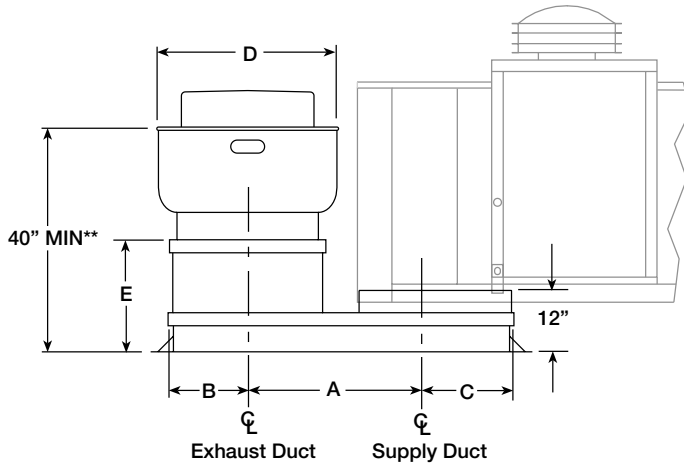

Note: Dimensions are shown with an 8" Roof Curb.

FPE Model	CUBE Sizes	A	B	C	D	E
102	98,100,120,130	41.5	20.0	26.5	23.63	24.12
142	140,160	41.5	20.0	26.5	27.50	24.00
182	180,200	41.5	20.0	26.5	34.25	24.38
242	220,240	41.5	20.0	26.5	40.75	24.00
302	300	41.5	20.0	26.5	48.0	24.00
183	180,200	48.5	26.0	35.5	34.25	24.38
243	220,240	48.5	26.0	35.5	40.75	24.00
303	300	48.5	26.0	35.5	48.0	24.00
363	360	48.5	26.0	35.5	56.75	24.00

FPE Model: Last digit is housing size.

IG-100 to 300 Uses Housing 2, IG-400 to 800 Uses Housing 3.

See CUBE literature for complete dimensions and weights of CUBE fan.

**Minimum Distances Required per NFPA 96.

Approximate Unit Weights

Unit weights are approximate, they will change with blower and horsepower combinations. FPE weight does not include CUBE fan.

IG Size	Weight	FPE Weight
100	970	100
150	970	100
200	1000	100
250	1000	100
300	1050	100
400	1550	125
500	1750	125
600	1850	125
700/800	2000	125
1050/1200	2400	125

100% Outside Air/Recirculation Air IG-100 to 400 with Down Discharge

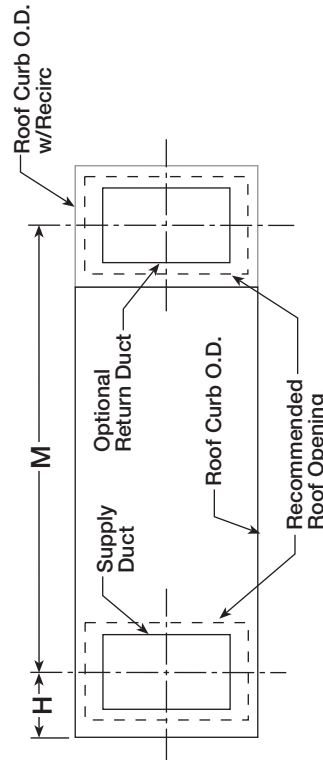
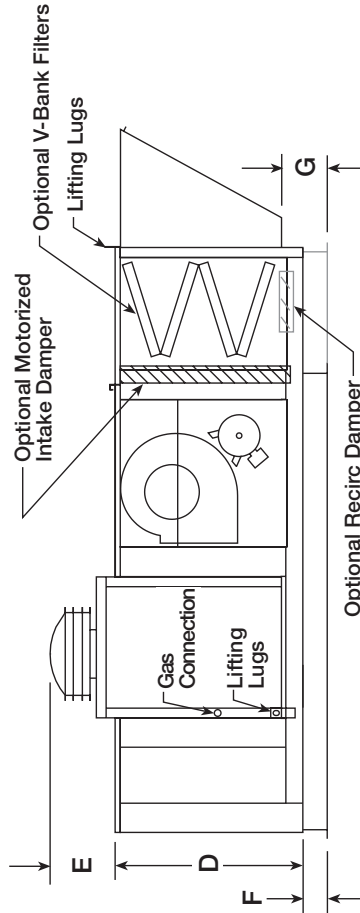
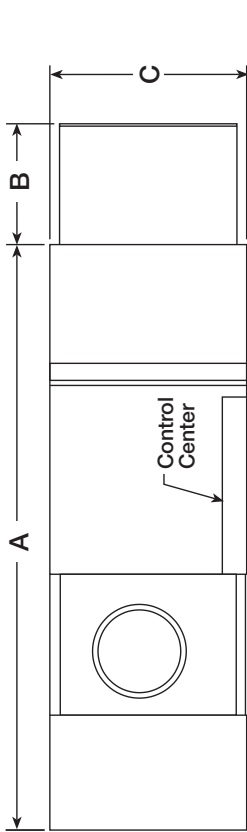

Unit Dimensions

Dim	IG-100	IG-150	IG-200	IG-250	IG-300	IG-400
A	120	120	120	120	120	136
B	24	24	24	24	24	30
C	40	40	40	40	40	52
D	38 1/2	38 1/2	38 1/2	38 1/2	38 1/2	48 1/2
E	10	13	15	15	28	18
F	Curb Height - 2 1/2					
G	Curb Height + 2					

Roof Curb Dimensions

Furnace Input	Supply Duct	Return Duct	Duct Locations		Roof Curb O.D.	Roof Curb O.D. w/Recirc	Supply Roof Opening	Return Roof Opening
			H	M				
100-300	18 x 30	17 x 30	12 3/4	92 1/4	38 1/2 x 88 1/2	38 1/2 x 118 1/2	22 x 34	22 x 34
400	24 x 40	17 x 42	15 3/4	105 1/4	50 1/2 x 106 1/2	50 1/2 x 134 1/2	28 x 46	22 x 46

**Intake Damper is in front of filter section on return air units.

100% Outside Air/Recirculation Air IG-500 to 800 with Down Discharge

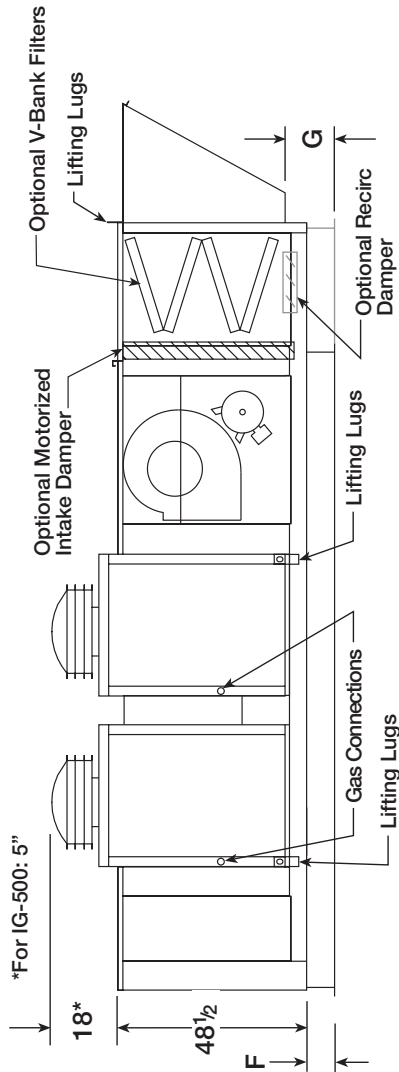
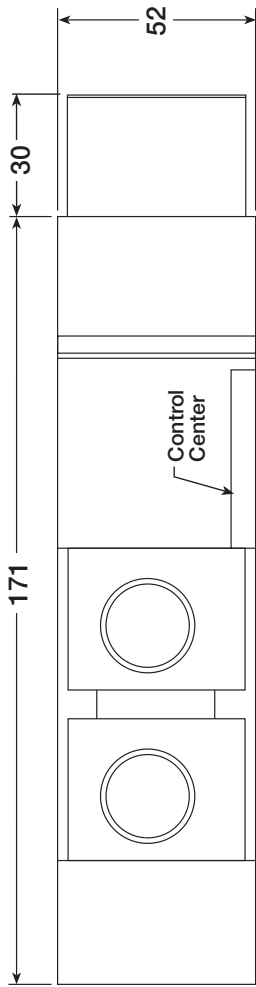

Unit Dimensions

F	Curb Height - 2 1/2
G	Curb Height + 2

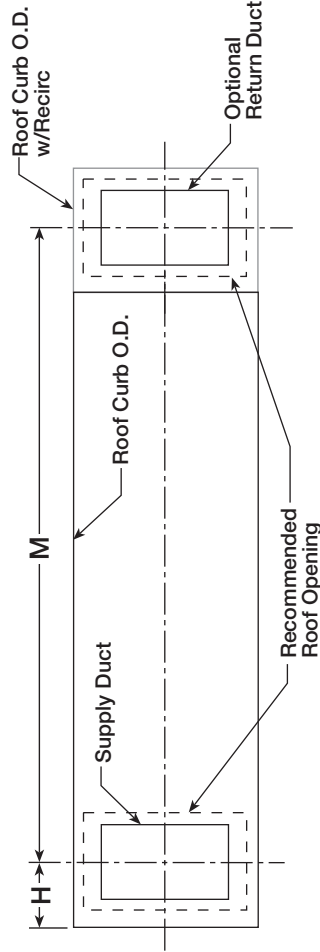

Roof Curb Dimensions

Furnace Input	Supply Duct	Return Duct	Duct Locations		Roof Curb O.D.	Roof Curb O.D. w/Recirc	Rec. Supply Roof Opening	Rec. Return Roof Opening
			H	M				
500-800	24 x 40	17 x 42	15 3/4	13 1/2	50 1/2 x 140 1/2	50 1/2 x 168 1/2	28 x 46	22 x 46

**Intake Damper is in front of filter section on return air units.

100% Outside Air/Recirculation Air IG-1050 and 1200 with Down Discharge

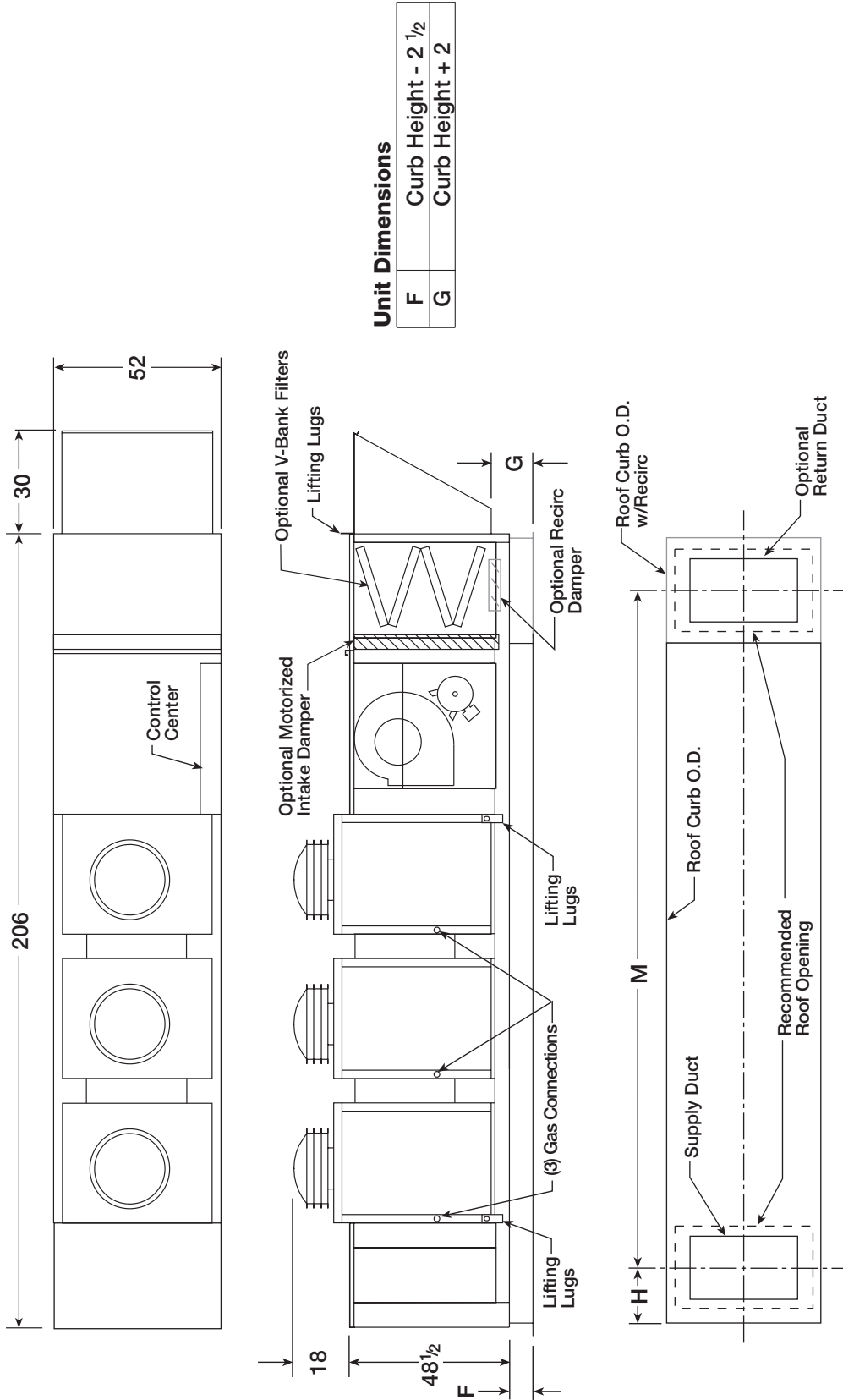

Unit Dimensions

F	Curb Height - 2 1/2
G	Curb Height + 2

Roof Curb Dimensions

Furnace Input	Supply Duct	Return Duct	Duct Locations		Roof Curb O.D.	Roof Curb O.D. w/Recirc	Supply Roof Opening	Return Roof Opening
			H	M				
500-800	24 x 40	17 x 42	15 3/4	176 3/4	50 1/2 x 176 1/2	50 1/2 x 204 1/2	28 x 46	22 x 46

**Intake Damper is in front of filter section on return air units.

100% Outside Air/Recirculation Air IG-100 to 400 with Horizontal Discharge

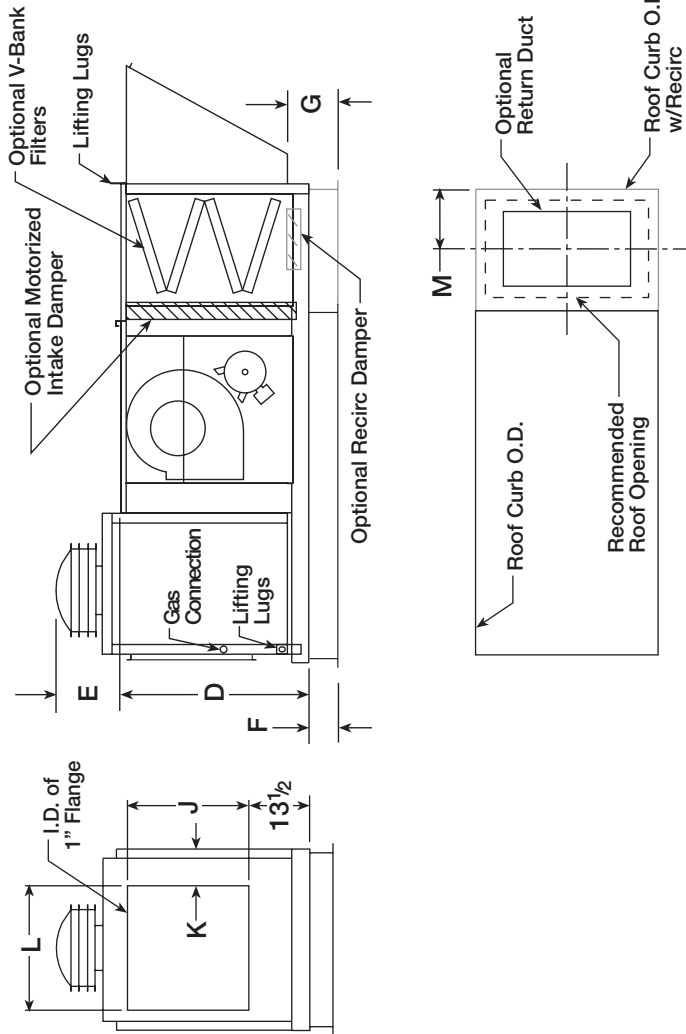
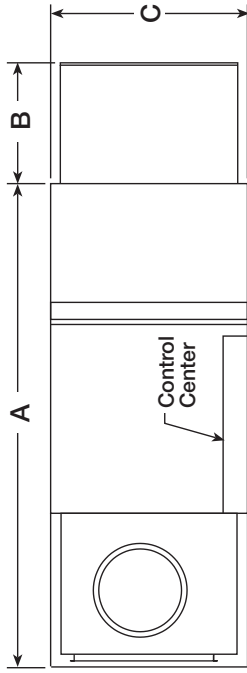

Unit Dimensions

Dim	IG-100	IG-150	IG-200	IG-250	IG-300	IG-400
A	98	98	98	98	98	109
B	24	24	24	24	24	30
C	40	40	40	40	40	52
D	38 1/2	38 1/2	38 1/2	38 1/2	38 1/2	48 1/2
E	10	13	15	15	28	18
J	19	24	24	24	24	24
K	11 3/4	11 3/4	9 1/2	8	5 1/2	8 1/4
L	19 3/4	20	24 1/2	27 1/2	32 1/2	38 3/4
F	Equipment Support Height - 2 1/2					
G	Equipment Support Height + 2					

Roof Curb Dimensions

Furnace Input	Roof Curb O.D.	Roof Curb O.D. w/Recirc	Return Duct	Location	Return Roof Opening
100 - 300	38 1/2 x 67 1/2	38 1/2 x 96 1/2	17 x 30	M	22 x 34
400	50 1/2 x 77 1/2	50 1/2 x 106 1/2	17 x 42	M	22 x 47

**Intake Damper is in front of filter section on return air units.

100% Outside Air/Recirculation Air IG-500 to 800 with Horizontal Discharge

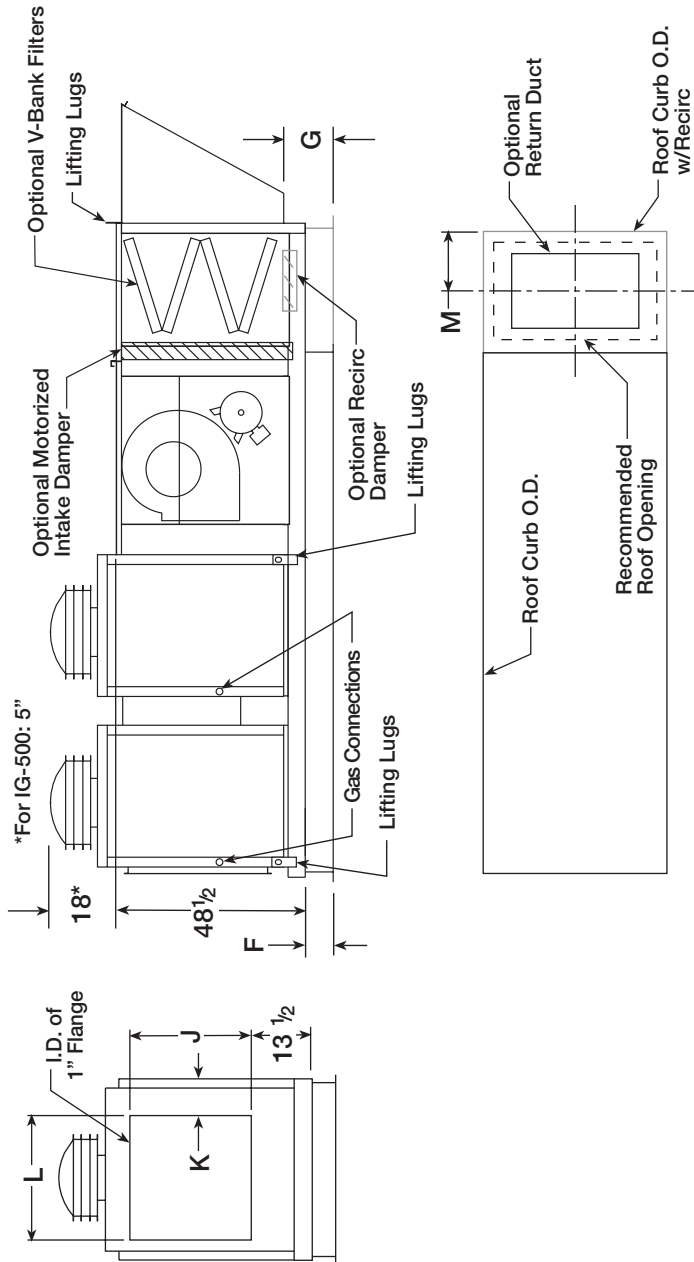
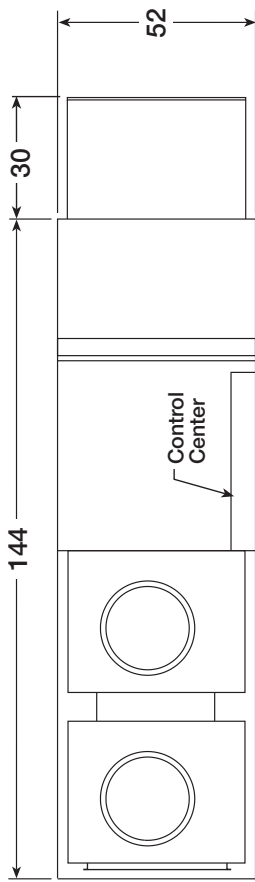

Unit Dimensions

Dim	IG-500	IG-600	IG-800
J	24	24	24
K	13	11 1/2	8 1/4
L	27 1/2	32 1/2	38 3/4
F	Curb Height - 2 1/2		
G	Curb Height + 2		

Roof Curb Dimensions

Furnace Input	Roof Curb O.D.	Roof Curb O.D. w/Recirc	Return Duct	Location	Return Roof Opening
500 - 800	50 1/2 x 112 1/2	50 1/2 x 140 1/2	17 x 42	M	22 x 46

**Intake Damper is in front of filter section on return air units.

Units with Combination Extension IG-100 to 400

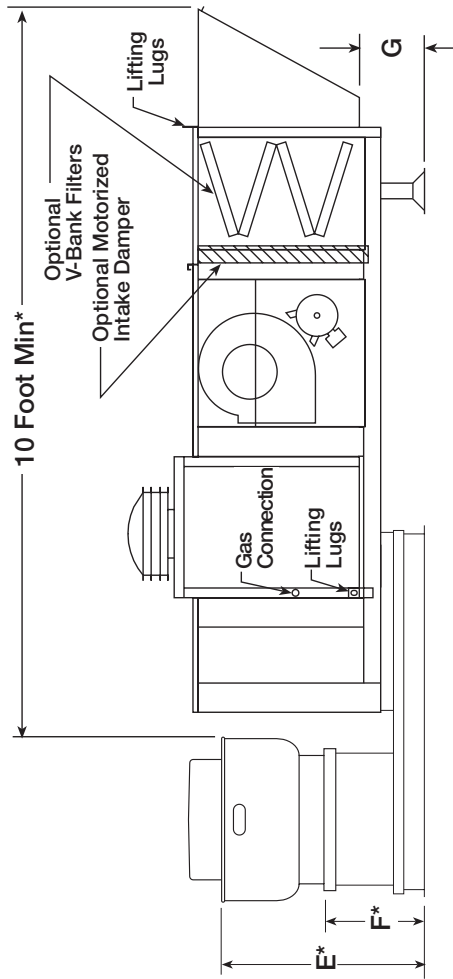
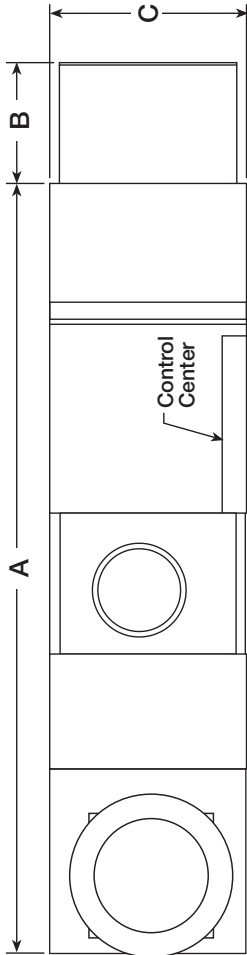

Unit Dimensions

	IG-100	IG-150	IG-200	IG-250	IG-300	IG-400
A	168	168	168	168	168	194
B	24	24	24	24	24	30
C	40	40	40	40	40	52
E*	47" Min					
F*	24" Min per NFPA 96 must use min 8" Roof Curb					
G	Curb Height + 6					

* Dimensions meet minimums required by NFPA 96.

Roof Curb Dimensions

Furnace Input	Supply Duct	H	J	K	L	Roof Curb O.D.	Recommended Roof Opening
100-300	18 x 30	12 ^{3/4}	24	17 ^{1/2}	87	38 1/2 x 86 1/2	35 x 83
400	24 x 40	15 ^{3/4}	29	19 ^{1/2}	100	50 1/2 x 108 1/2	47 x 105

See CUBE literature for recommended exhaust duct sizes.

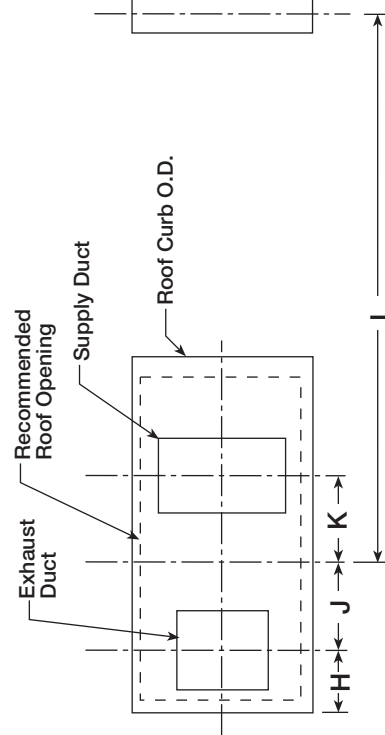

**Intake Damper is in front of filter section on return air units.

Units with Combination Extension IG-500 to 800

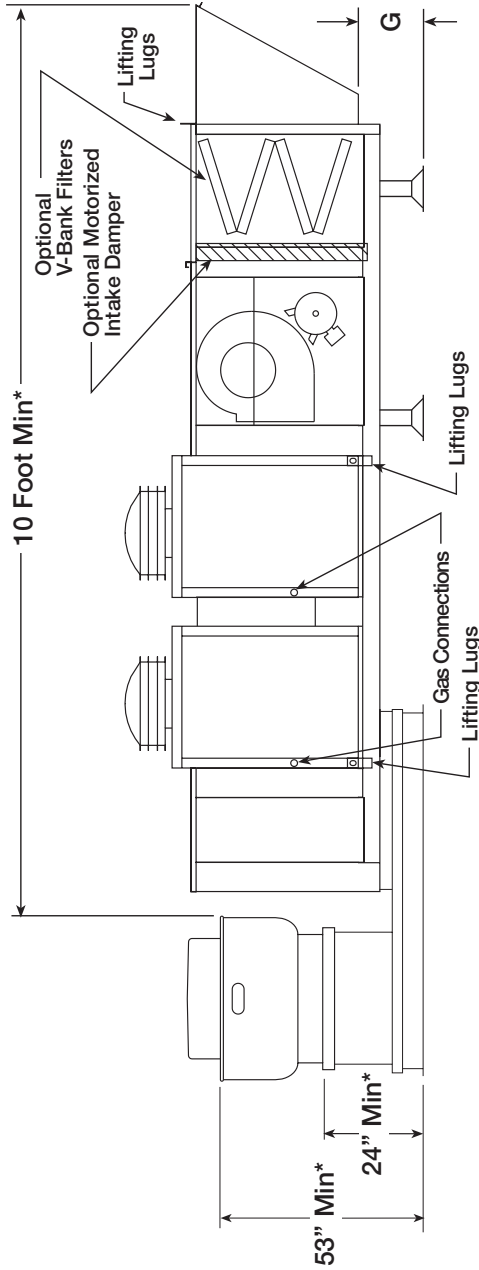
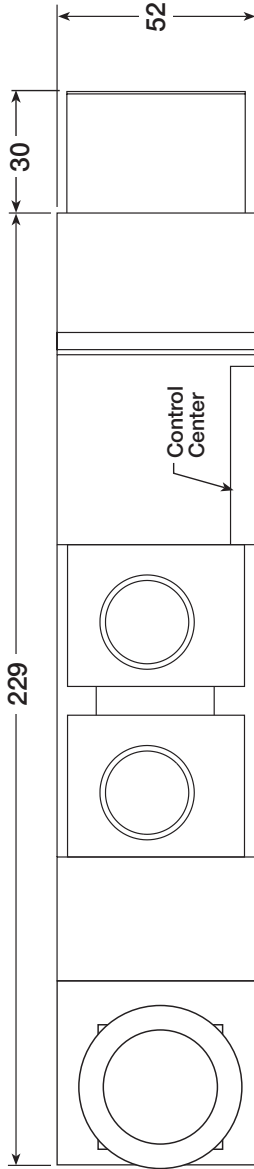

* Dimensions meet minimums required by NFPA 96.
8" minimum curb height must be used.
G = Curb Height + 6

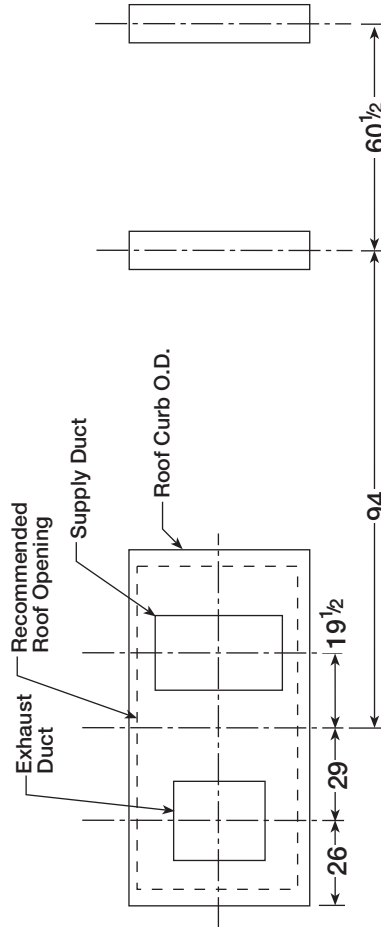

Roof Curb Dimensions

Furnace Input	Supply Duct	Roof Curb O.D.	Recommended Roof Opening
500 - 800	24 x 40	50 1/2 x 108 1/2	47 x 105

See CUBE literature for recommended exhaust duct sizes.

Units with Combination Extension IG-1050 & 1200

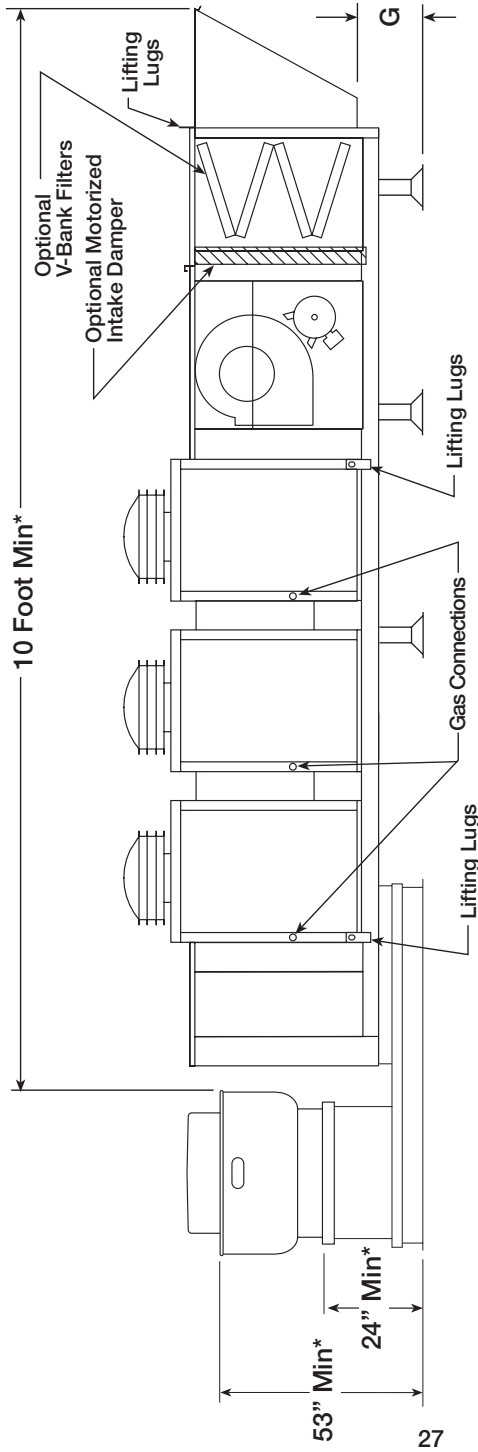
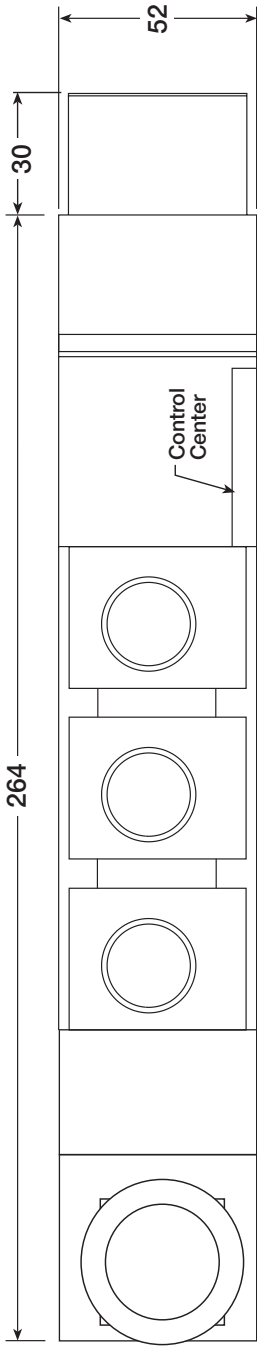

* Dimensions meet minimums required by NFPA 96.
8" minimum curb height must be used.
G = Curb Height + 6

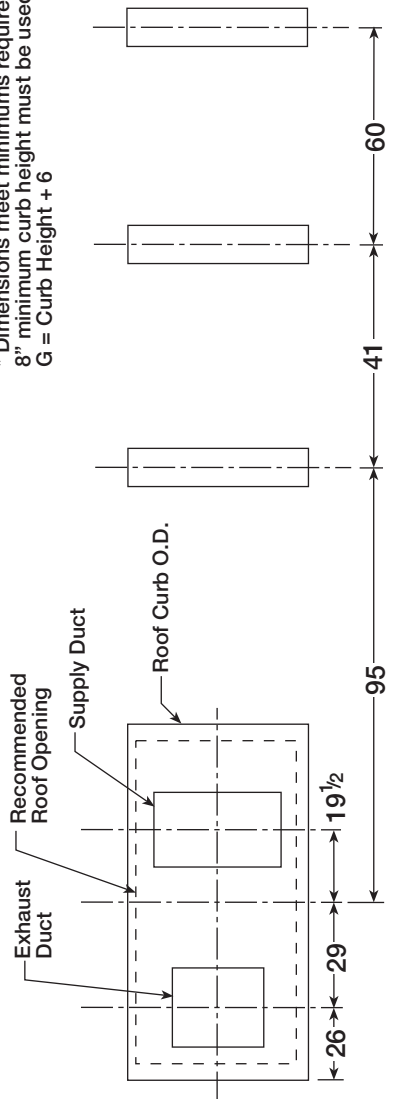

Roof Curb Dimensions

Furnace Input	Supply Duct	Roof Curb O.D.	Recommended Roof Opening
500 - 800	24 x 40	50 1/2 x 108 1/2	47 x 105

See CUBE literature for recommended exhaust duct sizes.

