

Application and Design

Model HPR-330 is a heavy duty pressure relief damper with double flanged channel frame and streamlined airfoil blades. It is designed to protect HVAC systems and industrial processes by relieving air pressure. External spherical rod end linkage, externally mounted relubricable ball bearings, blade counterbalance and adjustable pressure setting weights are standard so as to withstand elevated relief pressures and flows.

Ratings (See page 2 for specific limitations)

- Pressure Relief:** 0.5 in. wg minimum
6.0 in. wg maximum
- Back Pressure:** 8.5 - 20 in. wg
- Velocity:** 5150 - 6400 fpm
- Temperature:** Minimum: -40°F
Maximum: 250°F
Consult factory for temp. above 250°F.

Standard Construction (See page 3 for options)

- Frame:** 8" x 2" x 10 ga. galvanized steel channel.
- Blades:** Airfoil shaped, 16 ga. galvanized steel double skin construction, edge pivoted, 7" max. spacing.
- Blade Seals:** Silicone rubber.
- Axles:** Plated steel 3/4" dia.
- Linkage:** External heavy duty type with galvanized steel crankarms and 3/8" spherical rod ends with 3/8" threaded rod interconnect.
- Bearings:** Relubricable ball.
- Pressure Set:** Adjustable arms and weights.
- Finish:** Mill galvanized.

Size Limitations:

- Maximum Single Section Size: 48" W x 96" H
- Maximum Double Section Size: 96" W x 96" H
- Minimum Size: Single blade 6" W x 6" H

Advise flow direction, relief pressure, & counterbalance weight location when ordering

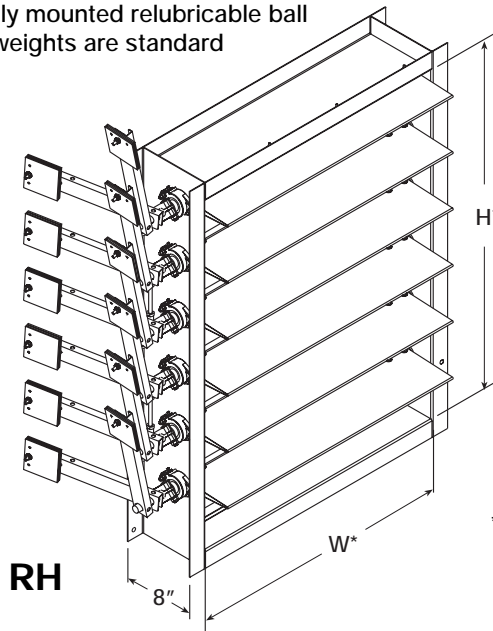

- H***
- LH**
- W***
- RH**
- * Actual Inside Dimension.
- ** The W dimension is ALWAYS parallel with the damper blade length.
- *** RH counterbalance and pressure setting are standard.
- **** Counterbalance and pressure setting weights extend beyond flanges in the open/closed positions.

Counterbalance & Pressure Setting Weight Dimensions

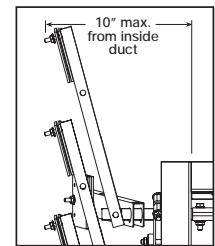
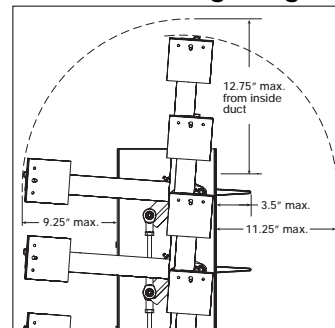

Front View
Side View

Frame		Blades		Seals		Axles		Bearings		Options	
Standard 10 ga. galv. steel		Standard Galv. steel		Standard Silicone Rubber Blade Seals		Standard Plated Steel 3/4" dia.		Standard Relubricable Ball		Bolt Holes in Flanges	
10 ga. 304 SS		304 SS		None		Type 304 Stainless Steel 3/4" dia.					

Quantity	Flow Direction (i.e.) Vertical Up Vertical Down Horizontal	Relief Pressure (in. wg)	W Width	H Height	Frame Depth C 8" Std.	Flange Width D 2" Std.	Bolt Hole information (See pg. 3)							Counterbalance Weight Location (i.e.) Right Hand, Left Hand, or Both
							J	F	L Spacing	M Dia.	U	V	Y	

Project	Location
Contractor	Design Specifier

Back Pressure Limitations

The chart at the right shows conservative pressure limitations based on a maximum blade deflection of $w/360$.

Temperature Limitations

-40°F to +250°F

For higher temperatures consult Greenheck

Velocity Limitations

The chart at far right shows conservative velocity limitations based on damper size.

Pressure Limitations

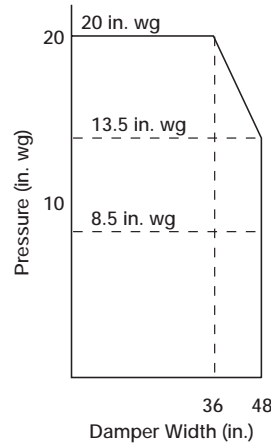

Velocity Limitations

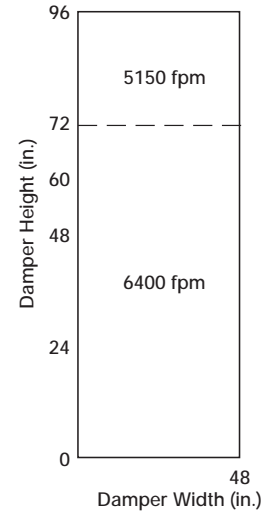

Pressure Relief/Leakage Data

This pressure drop data was conducted in accordance with AMCA Standard 500 using the configuration shown. All data has been corrected to represent standard air at a density of 0.075 lb/cu.ft.

AMCA Test Figure

Figure 5.5 illustrates a plenum mounted damper. This configuration has high pressure drop because of entrance and exit losses due to the sudden changes of area in the system.

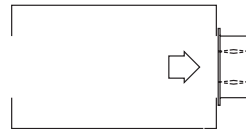
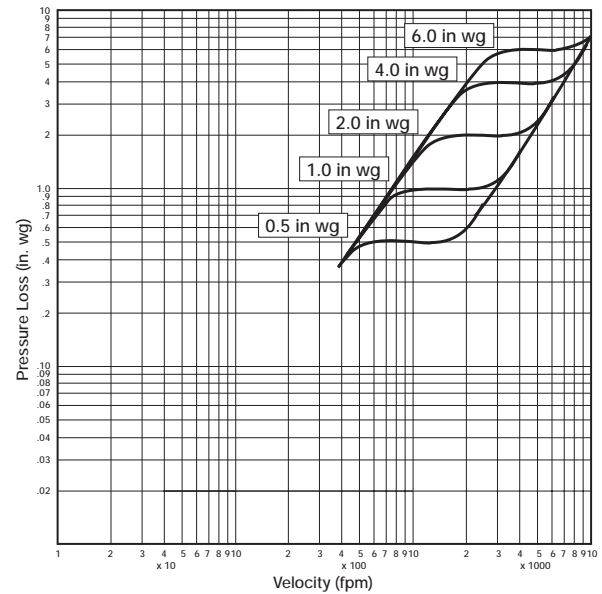

Fig. 5.5

AMCA Test Figures

**Pressure Relief/Leakage
36"x 36" Damper**



Material Options

Frame: Standard - 10 ga. galvanized steel
 Optional - 10 ga. 304 stainless steel

Axles: Standard - 3/4" dia. plated steel
 Optional - 3/4" dia. type 304 stainless steel

Blades: Standard - 16 ga. galvanized steel
 Optional - 16 ga. 304 stainless steel

Bearings: Standard - Externally mounted relubricable sealed ball

Frame Construction Options

Flange (D Dim.): Standard - 2"
 Optional - 1 1/2" - 4"

Bolt Holes: Standard - Does not include bolt holes
 Optional - Greenheck recommended standard pattern.
 7/16" Dia. holes (M dimension) Spaced 6" C-C (L dimension)
 Optional - Customer may specify within limits shown in table below.

Web (C Dim.): Standard - 8"
 Optional - 8" - 12"

Dim.	Standard (Min./Max.)	Description
J	(D/2 min.)	First/Last Space in Jamb
F	(1 min.)	No. of Holes in Jamb
L	6" (2"/12")	Hole Spacing
M	7/16" (1/4" / 11/16")	Mounting Hole Diameter
U	(3/4" min.)	First/Last Space in Head/Sill
V	(1 min.)	No. of Holes in Head/Sill
Y	D/2" (3/4" / D - 3/4")	Centerline of bolt hole from inside edge of frame

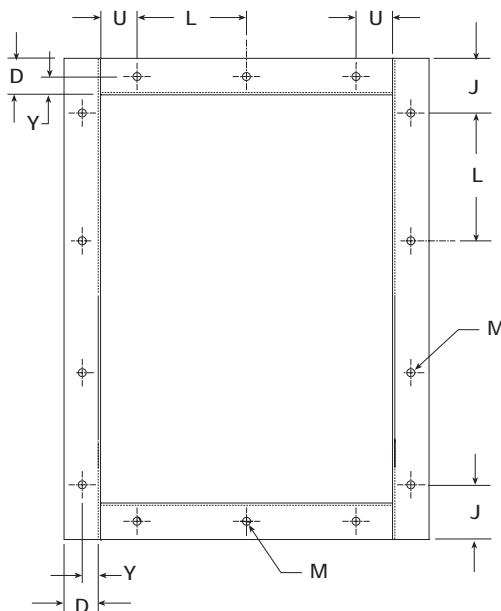

Multiple Section Assembly

Damper sizes larger than 48"x96" and up to 96"x96" will be supplied in one frame with two sets of blades separated by a mullion as shown below. Counterbalance and pressure set weights supplied on right hand and left hand side. For sizes larger than 96"x96" consult factory.

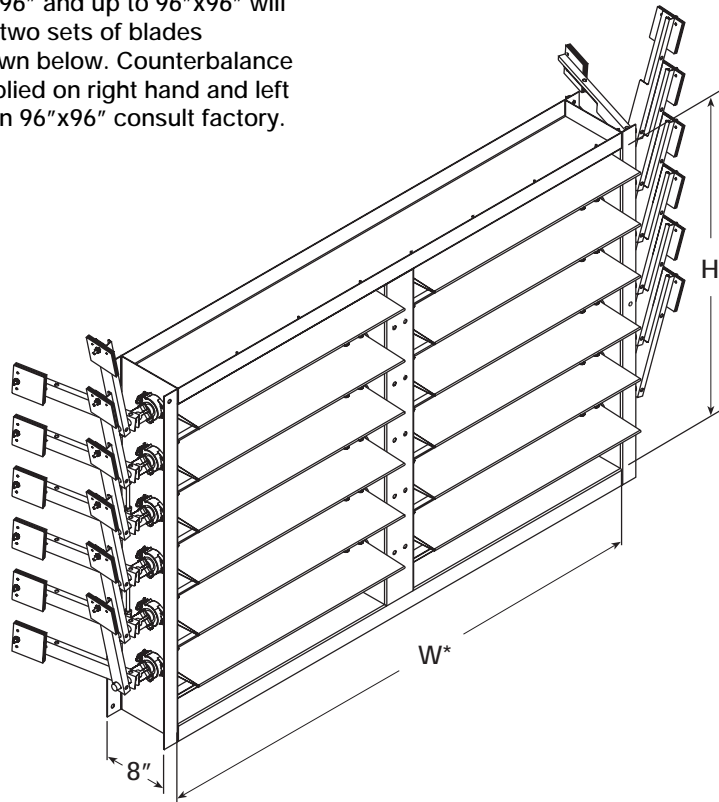

Specifications

Industrial grade pressure relief dampers meeting the following specifications shall be furnished and installed where shown on plans and/or as described in schedules. Dampers shall consist of: a 10 ga. galvanized steel channel frame with 8" minimum depth and 2" flanges; airfoil shaped, 16 ga. galvanized steel double skin construction blades; silicone rubber blade seals; 3/4" dia. plated steel axles turning in externally mounted relubricable sealed ball bearings; and external (out of the airstream) precision 3/8" spherical rod end linkage with

counterbalance and pressure set weights. Damper manufacturer's printed application and performance data including pressure, velocity and temperature limitations shall be submitted for approval showing damper suitable for back pressures to 20 in. wg, relief pressures to 6 in. wg, velocities to 6400 fpm, and temperatures to 250°F. Testing and ratings to be in accordance with AMCA Standard 500. Basis of design is Greenheck model HPR-330.