

Model GRS

GRAVITY VENTILATORS

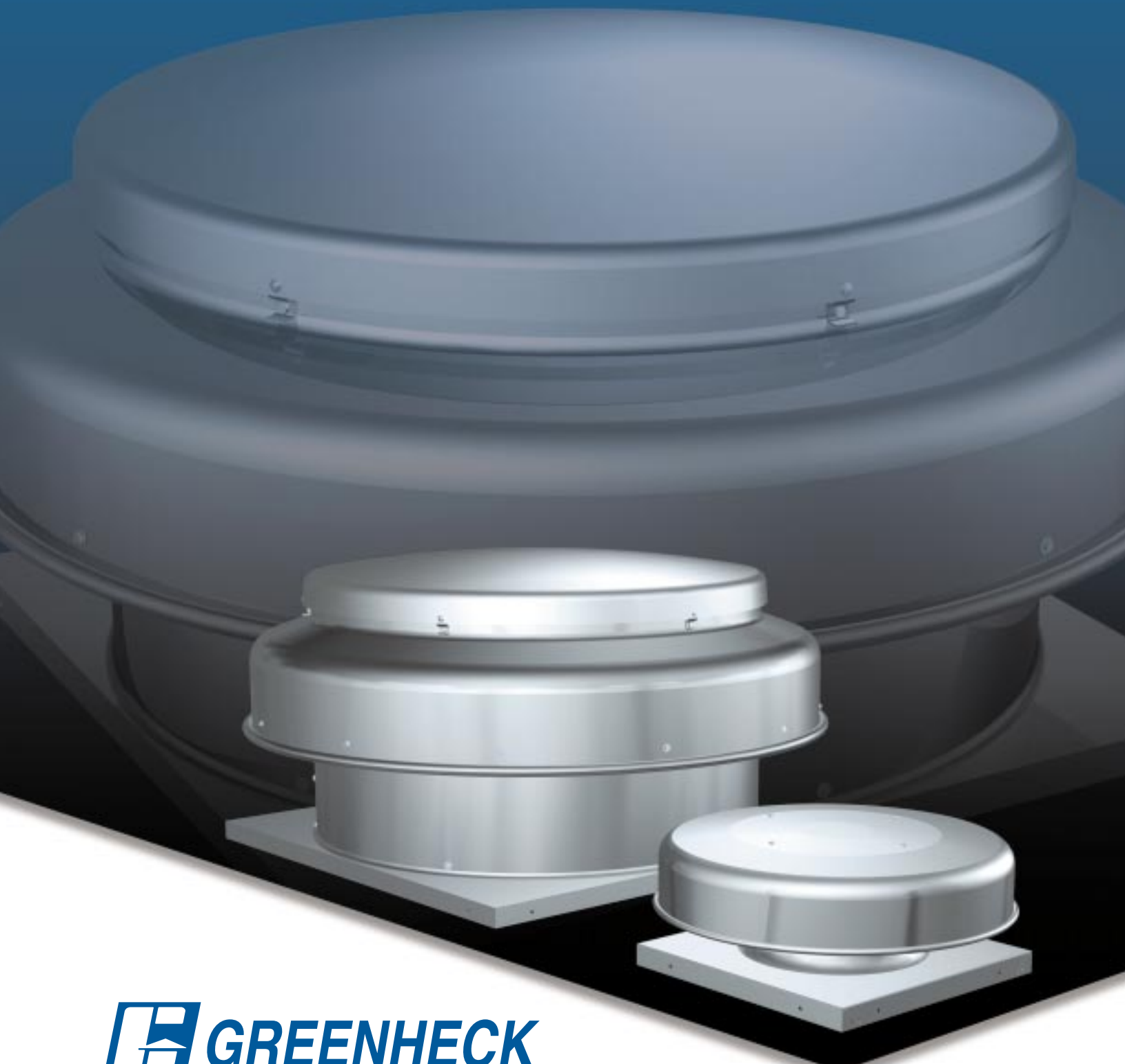



Spun Aluminum Ventilator

When you buy a Greenheck Model GRS, you receive a ventilator with the industry's best performance and durability for intake or relief on natural gravity or positive pressure systems.

- Broadest performance in the industry, up to 18,200 cfm.
- Most advanced weather protection of any ventilator in its class.
- Performance as cataloged is assured. All sizes are tested in our AMCA Registered Laboratory.
- Greenheck subjects these products to extensive life testing, assuring that the ventilator will provide years of reliable performance.

Leading Edge Support

When you need extensive product and IOM (Installation and Operating Manual) information, our products are supported by the industry's best product literature, electronic media, and computer aided selection program (CAPS). You'll also find this information on our website at www.greenheck.com



You can always count on personal service and expertise from our national and international representative organization. To locate your nearest Greenheck representative, call 715-359-6171 or visit our website at www.greenheck.com

www.greenheck.com

World Class Manufacturing

Our advanced manufacturing processes and quality control procedures always ensure the highest product quality. Our skilled production workers use cost-effective machines and unique die designs built by our own engineers to add innovative features and greater strength to our gravity ventilators.

Quick Delivery and Quick Build Programs

You can order from more than 9 GRS configurations, hundreds of in-stock ventilation products, and accessories that can ship to your job site, in less than 24 hours from our four strategically located warehouses. Speed up your process even more, order your units over the Internet using QD Online at www.greenheck.com/qd

**GREENHECK
QUICK
DELIVERY**



For other sizes and configurations where rapid response time is required, our Quick Build (QB) Program can manufacture and ship your custom products in one, three, five or ten days.

DIMENSIONAL DATA

MODEL	A	B	C	D	DIA.	DAMPER SIZE	CURB MATERIAL	SHROUD MATERIAL
GRS-8	19	20 1/2	7 3/4	1 1/2	8 1/4	8 X 8	0.051	0.051
GRS-10	19	20 1/2	7 3/4	2	10 1/4	10 X 10	0.051	0.051
GRS-12	22	29	10	3 1/2	12 1/4	12 X 12	0.064	0.064
GRS-15	22	29	10	3 1/2	14 1/4	16 X 16	0.064	0.064
GRS-16	26	29	11	4 1/4	16 1/4	16 x 16	0.064	0.064
GRS-18	30	35 1/2	10 1/2	3 1/8	18 1/4	18 x 18	0.064	0.064
GRS-20	30	35 1/2	11 1/4	3 3/4	20 1/4	18 X 18	0.064	0.064
GRS-24	34	38 1/4	11	4	24 1/2	24 X 24	0.064	0.064
GRS-30	40	48	18 3/4	5 7/16	30 1/2	30 X 30	0.064	0.064
GRS-36	46	56 3/4	21 1/4	6	36 1/2	36 X 36	0.064	0.080
GRS-42	52	63 1/4	24 1/4	6 1/4	42 1/2	42 X 42	0.064	0.080
GRS-48	58	72	26 1/4	6 1/2	48 1/2	48 X 48	0.064	0.080

NOTE: Models GRS-8 through GRS-24 have a one piece cover and shroud. Access is gained through the removal of screws. Models GRS-30 through GRS-48 have a removable cover, separate from the shroud, to facilitate maintenance and servicing of dampers.

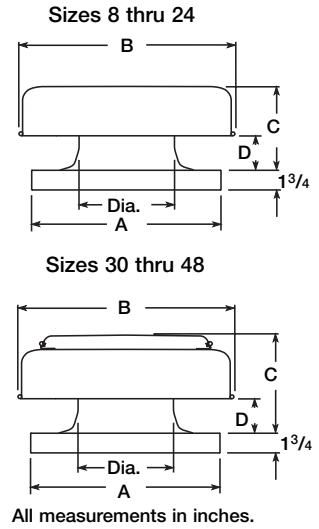

PERFORMANCE DATA

Performance data for these units was obtained through actual testing. The information is presented in capacity versus TOTAL PRESSURE DROP THROUGH THE GRS. Total pressure drop includes the static and velocity pressure drops. To find the static drop alone, use the following equations.

$$\text{Throat Velocity} = \frac{\text{CFM}}{\text{Throat Area}} \quad \text{Velocity Pressure} = \left[\frac{\text{Throat Velocity}}{4002} \right]^2$$

$$\text{Static Pressure} = \left[\text{Total Pressure} \right] - \left[\text{Velocity Pressure} \right]$$

The data is presented for both discharge and intake units. The intake velocity of the intake unit should not exceed 600 feet per minute. Above this velocity, air borne particles may be carried into the building. The opposing table displays the maximum recommended values for the respective intake units.

In areas where snow depths may be a problem, 12 inch or higher curbs are recommended.

GRS Recommended Maximum Intake Capacities

UNIT	Intake Area (Ft. ²)	Max. CFM Intake
GRS-8	1.30	780
GRS-10	1.72	1032
GRS-12	2.52	1512
GRS-15	2.57	1542
GRS-16	3.02	1812
GRS-18	3.76	2256
GRS-20	4.43	2658
GRS-24	4.95	2970
GRS-30	7.493	4496
GRS-36	10.186	6111
GRS-42	11.932	7159
GRS-48	15.477	9286

Table based on 600 fpm maximum intake velocity. Above these values, provisions should be made to contain incoming moisture.

MODEL GRSI Intake Performance

Model	Throat Area (Ft. ²)	Total Pressure Drop in Inches of W.G.								
		0.04	0.06	0.08	0.10	0.125	0.187	0.250	0.300	0.350
GRSI-8	0.37	182	224	257	286	315	394	448	493	530
GRSI-10	0.57	283	348	399	445	490	611	697	765	823
GRSI-12	0.82	406	500	572	637	702	876	999	1097	1180
GRSI-15	1.12	560	690	790	880	970	1210	1380	1515	1630
GRSI-16	1.45	751	925	1059	1180	1301	1623	1850	2031	2186
GRSI-18	1.83	913	1124	1286	1434	1580	1972	2248	2468	2656
GRSI-20	2.25	1111	1368	1565	1745	1923	2399	2735	3003	3232
GRSI-24	3.24	1440	1820	2120	2418	2722	3330	3836	4235	4580
GRSI-30	5.032	1770	2360	2580	3270	3680	4470	5130	5524	5820
GRSI-36	7.291	2567	3420	4127	4739	5330	6475	7430	8006	8436
GRSI-42	9.765	3437	4580	5527	6347	7138	8671	9950	10722	11298
GRSI-48	12.830	4516	6017	7262	8339	9378	11393	13073	14087	14844

MODEL GRSR Relief Performance

Model	Throat Area (Ft. ²)	Total Pressure Drop in Inches of W.G.								
		0.04	0.06	0.08	0.10	0.125	0.187	0.250	0.300	0.350
GRSR-8	0.37	203	250	291	325	365	462	559	636	713
GRSR-10	0.57	310	387	450	505	570	695	814	908	1003
GRSR-12	0.82	440	557	643	724	818	1000	1165	1290	1395
GRSR-15	1.12	630	762	890	1004	1125	1375	1625	1819	2014
GRSR-16	1.45	820	1025	1190	1340	1515	1845	2160	2385	2610
GRSR-18	1.83	995	1240	1440	1630	1835	2245	2615	2910	3189
GRSR-20	2.25	1220	1520	1785	1995	2235	2730	3166	3513	3859
GRSR-24	3.24	1780	2215	2580	2920	3255	3990	4650	5140	5650
GRSR-30	5.032	2460	2890	3260	3615	4015	4920	5665	6222	6778
GRSR-36	7.291	2990	3820	4515	5075	5670	6990	8140	9005	9820
GRSR-42	9.765	4200	5400	6320	7030	7820	9710	11450	12850	14210
GRSR-48	12.830	5900	7500	8800	9850	11050	13750	15650	16950	18200

Typical Specifications For Model GRS

Spun Aluminum Gravity Roof Ventilator shall be provided as follows:

Exterior construction shall be heavy gauge aluminum windband with a rolled bead.
Curb cap shall be constructed of heavy gauge aluminum and includes a one piece spun venturi.
Curb cap shall be prepunched for mounting.
Internal components shall be constructed of rigid galvanized steel with birdscreen.
Model GRS as manufactured by Greenheck, in Schofield, Wisconsin.

The GRS can be used with the following accessories:

Gravity or motorized dampers to assure weather tightness.
Prefab curbs to reduce installation time.
Protective coatings to extend the life of the unit or blend its color with other equipment.

Warranty

Greenheck warrants this equipment to be free from defects in material and workmanship for a period of one year from the purchase date. Any units or parts which prove defective during the warranty period will be replaced at our option when returned to our factory, transportation prepaid.

Due to continuing research, Greenheck reserves the right to change specifications without notice.



Number one in air movement and control.



Centrifugal and Vane Axial Fans



Fans and Ventilators



Energy Recovery Ventilators & Make-Up Air Units



Kitchen Ventilation Systems



Dampers and Louvers

Visit the Greenheck website for the most current information available
www.greenheck.com

Greenheck • P.O. Box 410 Schofield, WI 54476-0410 • Phone (715) 359-6171 • Fax (715) 355-2399 • www.greenheck.com