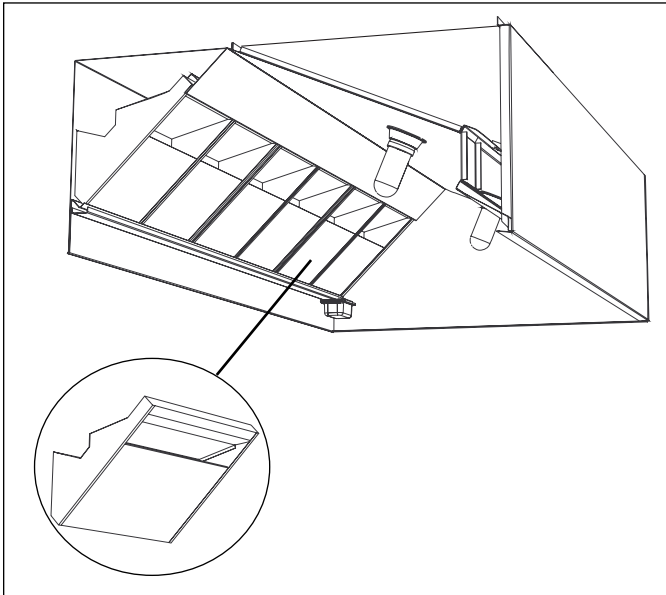

High Velocity Cartridge Filter / Wall Style Canopy

SPECIFICATION AND APPLICATION:

Provide Greenheck Exhaust Hood Model GKSX as shown on plans and in accordance with the following specification:

Kitchen ventilation hood(s) shall be Type I, exhaust only canopy suitable for all types of cooking applications. Hood(s) shall include a fully insulated make-up air plenum designed to introduce untempered air inside the hood canopy, with adjustable balancing dampers to allow volume control. Hood(s) to be UL 710 Listed Without (With) Fire Dampers for 600° rated cooking appliances.

Hood(s) shall be constructed of a minimum 18 gauge type 304 stainless steel, with a #4 finish. The hood(s) shall be constructed using the standing seam method for optimum strength. Front and end panels shall have stamped vertical ribs, evenly spaced, to add additional strength and rigidity. All external seams shall be welded liquid tight in accordance with NFPA # 96. Lighter material gauges, alternate material types, finishes, and nonliquid tight welded construction are not acceptable. All unexposed interior surfaces shall be constructed of a minimum 18 gauge corrosion resistant steel including, but not limited to ducts, plenum, and brackets.

Hood(s) shall include UL 1046 Classified and NSF Certified high velocity cartridge filters manufactured by Greenheck, in sufficient number and sizes to ensure optimum performance. High velocity cartridge filters shall direct the exhaust airflow across a series of horizontal baffles, utilizing centrifugal impingement grease extraction technology. The filter housing shall terminate in a pitched, full-length grease trough, which shall drain into a removable grease container.

Vaporproof, UL Listed incandescent light fixtures shall be prewired to a junction box. Wiring shall conform to the requirements of the National Electrical Code (NEC #70 - Latest Edition).

MODEL GKSX

Type - Short Circuit Supply

- U.L. Listed without Fire Damper
(UL File No. MH11726)
- U.L. Listed with Fire Damper
(UL File No. MH10897)

STANDARD FEATURES:

- UL Listed and NSF Certified
- 18 Ga. 304 SS construction with continuously welded external seams in accordance with NFPA # 96
- UL 1046 Classified and NSF Certified stainless steel high velocity cartridge filters
- Sizes - 48 in. to 192 in. lengths, 42 in. to 60 in. widths, 24in. or 30in. heights
- Insulated short circuit supply air plenum
- Vertical stamped ribs for added strength
- Complies with all National Codes and Standards, including UL, NSF, NFPA # 96, IMC, (including BOCA, SBCCI, and ICBO)

OPTIONS:

- Duct collars shipped loose for field installation (factory attached standard)
- All stainless steel construction (18 Ga. 304 SS where exposed construction standard)
- Finished stainless steel back (for single island applications)
- Recessed fluorescent or recessed incandescent lights (globe incandescent lights standard)

ACCESSORIES:

- On / Off switches, hood mounted or remote mounted
- Filler panels for clearance to combustibles
- Stainless steel backsplash panel, insulated or non-insulated
- Enclosure panels to span from hood top to ceiling
- End skirts for improved capture and performance
- Thermostatically controlled automatic fire damper (fusible link fire damper standard for hoods UL Listed with Fire Dampers)
- Filter removal tool

Due to continuous research Greenheck reserves the right to change specifications without notice.

**Consult factory for possible restrictions*

Code Information

Greenheck Kitchen Hoods are built in accordance with the following codes, standards, and recommended practices.

- UL 710 Listed
- NFPA 96
- BOCA
- NSF
- SBCCI
- IMC / UMC



High Velocity Cartridge Filter / Wall Style Canopy

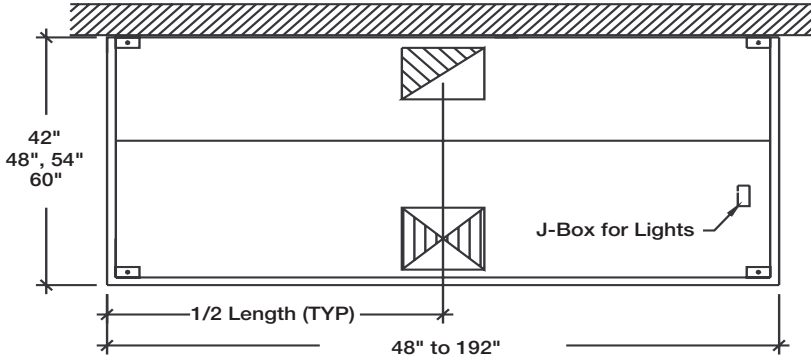

CFM Requirements

Exhaust air quantities vary depending on the type of cooking equipment used with the hood. Model GKS meets UL minimum exhaust requirements for operation as follows:

400° F	N/A
600° F	150 CFM per lineal foot*
700° F	N/A

For the most efficient hood selection, the *Greenheck Cooking Equipment Ventilation Application and Design* manual should be consulted.

* Consult factory for possible restrictions

* All dimensions appear in inches. *

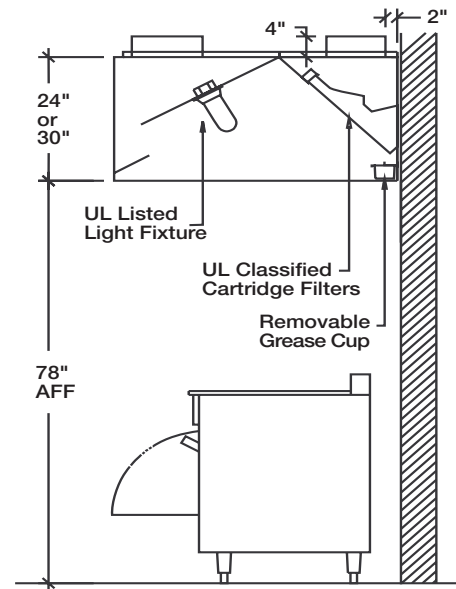
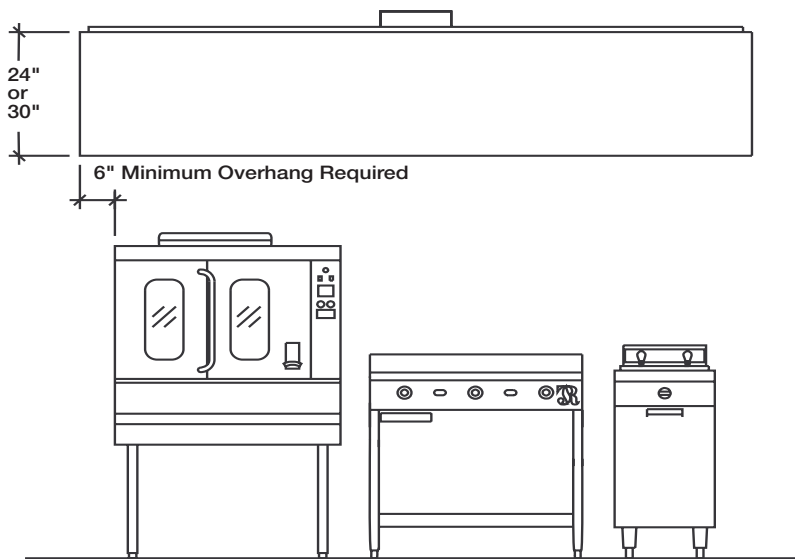

Complete Kitchen Ventilation Systems



Exhaust Hoods



Exhaust Fans



Make-Up Air Units

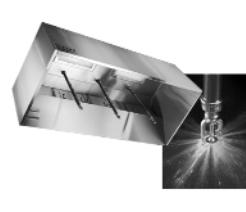

Fire Suppression



Utility Distribution

Visit the *Greenheck* website for the most current information available
www.greenheck.com

Greenheck • P.O. Box 410 • Schofield, WI 54476-0410 • Phone (715) 359-6171 • Fax (715) 355-2399 • www.greenheck.com