

Construction Features

- The casing is constructed of 18 gauge type 304 stainless steel. Unexposed surfaces are 18 gauge corrosion resistant steel. All seams are continuously welded liquid tight.
- Extractors are stainless steel, non-clogging high efficiency cartridge type and are easily removable for cleaning.
- The full length grease trough is pitched to drain grease from the extractors and exhaust plenum. Grease then drains from the trough into a removable grease container for disposal.
- U. L. Listed vaporproof incandescent light fixtures are prewired to a junction box mounted on top of the hood.
- The makeup air plenum is fully insulated with 1" foil face insulation to prevent condensation.

Options and Accessories

Hood Construction: Construction entirely of 16 gauge type 304 stainless steel is also available.

Light Fixtures: U.L. Listed fluorescent light fixtures are available, prewired and recessed into the hood.

Fire Suppression System: Factory prepiped fire suppression systems are available for the protection of the kitchen ventilation system and cooking appliances.

Enclosure Panels: Formed panels of the same material as the hood are available to provide a finished appearance by enclosing the area between the top of the hood and the ceiling.

Electrical Control Panels: Remote and face mounted canopy light and fan control switches are available to control kitchen ventilation operations.

MODEL GCSW

STYLE - Dry Cartridge

TYPE - Short Circuit Supply

- U.L. Listed without Fire Damper
- U.L. Listed with Fire Damper
- Island Application - Finished Back

Short Circuit Supply Type Kitchen Hoods

Model GCSW hoods are designed for wall and island applications. The short circuit supply type hood should be utilized to comply with codes that restrict exhaust volumes based on hood area.

Sizes

Model GCSW hoods are available in 3'6" to 5'0" widths. Lengths range from 4'0" to 16'0".

CFM Requirements

Exhaust air quantities vary depending on the type of cooking equipment used with the hood. Model GCSW meets UL requirements for operation as follows:

600° F 282 CFM/lineal foot* 70% Supply

For the most efficient hood selection, the *Greenheck Cooking Equipment Ventilation Application and Design* manual should be consulted.

Code Information

The Greenheck Model GCSW hood is constructed in compliance with the following:

- UL Listed with or without fire damper
- National Sanitation Foundation (NSF)
- National Fire Protection Association (NFPA) Bulletin #96
- International Conference of Building Officials (ICBO)
- Building Officials and Code Administrators (BOCA)
- Southern Building Code Congress International (SBCCI)

See the National Evaluation Report (NER) 436 for allowable values and/or conditions of use concerning materials presented in this document. (This report is subject to re-examination, revision, and possible closing.)

**MODEL
GCSW**

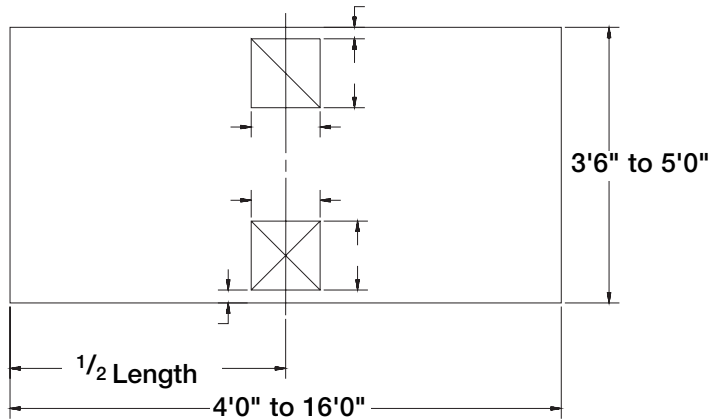
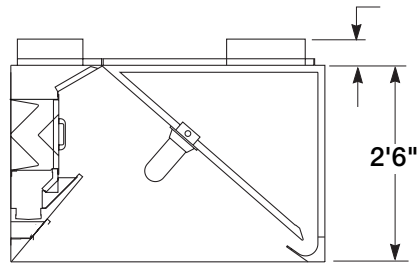

| Exhaust CFM | Collar Size |
|--------------|-------------|
| 735 to 850 | 8 x 8 |
| 851 to 1050 | 9 x 9 |
| 1051 to 1300 | 10 x 10 |
| 1301 to 1575 | 10 x 12 |
| 1576 to 1950 | 10 x 15 |
| 1951 to 2350 | 10 x 18 |
| 2351 to 2900 | 10 x 22 |
| 2901 to 3550 | 10 x 27 |
| 3551 to 4250 | 10 x 32 |
| 4251 to 4700 | 10 x 36 |
| 4701 to 5275 | 10 x 40 |
| Supply CFM | Collar Size |
| 500 to 970 | 12 x 12 |
| 971 to 1500 | 12 x 18 |
| 1501 to 2050 | 12 x 24 |
| 2051 to 2980 | 14 x 28 |
| 2981 to 3880 | 14 x 36 |
| 3881 to 4560 | 14 x 42 |

Typical Specifications

Kitchen Ventilation hood(s) shall be of the short circuit full canopy type with a fully insulated makeup air plenum designed to introduce untempered air under the hood.

Hood(s) shall be constructed of a minimum 18 gauge type 304 stainless steel, with a #4 finish. The hood(s) shall be constructed using the standing seam method for optimum strength. Front and end panels shall have stamped vertical ribs, evenly spaced, to add additional strength and rigidity. All external seams shall be welded liquid tight in accordance with NFPA # 96. Lighter material gauges, alternate material types, finishes, and nonliquid tight welded construction are not acceptable. All unexposed interior surfaces shall be constructed of a minimum 18 gauge corrosion resistant steel including, but not limited to ducts, plenum, and brackets.

The hood(s) shall include horizontal baffles to create high velocity centrifugal grease extraction. Horizontal baffles shall be in cartridge form, up to 24" in length, and removable for cleaning. The extractor housing shall terminate in a pitched, full length grease trough which shall drain into a removable grease container. The manufacturer shall be capable of documenting grease extraction efficiency up to 95% (per test method defined in U. S. Navy specification NBSIR 74-505).

Vaporproof, U.L. Listed incandescent (fluorescent) light fixtures shall be prewired to a junction box situated at the top of the hood for field connection. Wiring shall conform to the requirements of the National Electrical Code (NFPA #70- Latest Edition).

The canopy hood(s) shall be constructed by Greenheck of Schofield, Wisconsin. They shall be UL Listed without (with) fire damper and built in accordance with National Fire Protection Association (NFPA) Bulletin #96, International Conference of Building Officials (ICBO), Building Officials and Code Administrators (BOCA), Southern Building Code Congress International (SBCCI), and bear the National Sanitation Foundation (NSF) Seal of Approval. The hood manufacturer shall provide, on request, the necessary data that confirms compliance with the code authorities listed above (NER report required). The hood CFM values shall be calculated utilizing a computerized thermal updraft velocity method.

Due to continuous research Greenheck reserves the right to change specifications without notice.



Greenheck
P.O. Box 410
Schofield, WI 54476
Tel: 715/359-6171
Fax: 715/355-2399
www.greenheck.com