

ACCUSSETTERS

Hydronic System Balancing with Calibrated Venturis

Sizes 1/2" to 14"

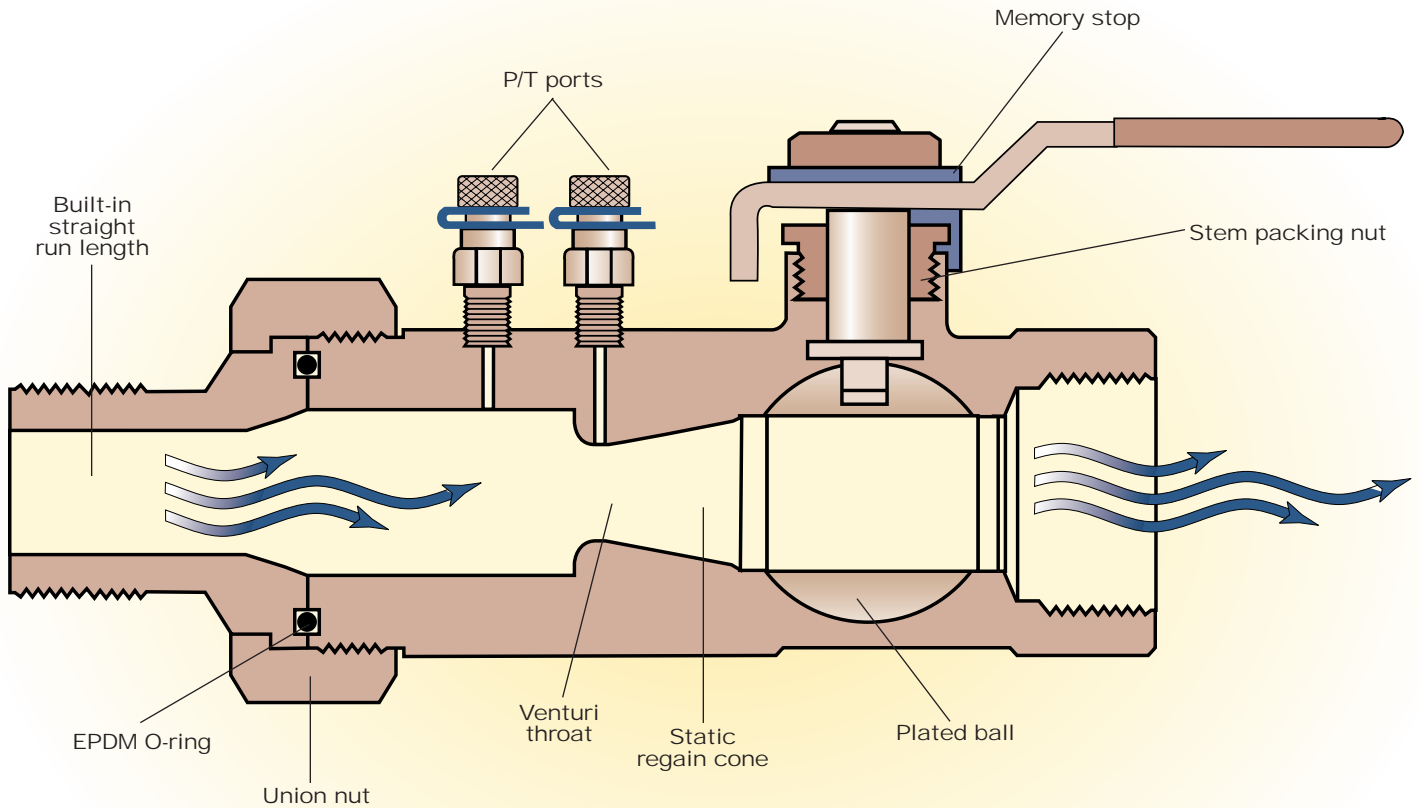

FLOW DESIGN INC.

Proportional Balancing for Hydronic Systems

ASHRAE recommends that manual balancing valves be placed on the coils, risers, branches, and pump discharge so that the system can be proportionally balanced. This method is preferred by most designers for **constant speed systems**. Proportional balancing strives to have all circuits with pressure drop equal to the index circuit which already has the most loss. In the typical layout shown below, the index circuit is highlighted. When proportional balancing is complete, the design GPM is achieved by trimming the pump impeller or throttling the pump balancing valve.

The illustration below has one major circuit piped direct return; the other reverse return. Reverse return

provides equal length distribution piping for all coil circuits and, in theory, requires only minor adjustment of the manual balancing valves. It also requires about 30% more distribution pipe. The reverse return loop provides each circuit with an equal length of distribution pipe; therefore, the high drop AHU coil becomes the index circuit.

CAUTION: Direct return, proportionally balanced systems are **not recommended for variable speed pumping systems**. The reason is that flow deficits may occur in some of the interior circuits. (See Flow Design Brochure F010, page 12 for more information.)

Typical Layout for System with Direct and Reverse Return Piped Risers

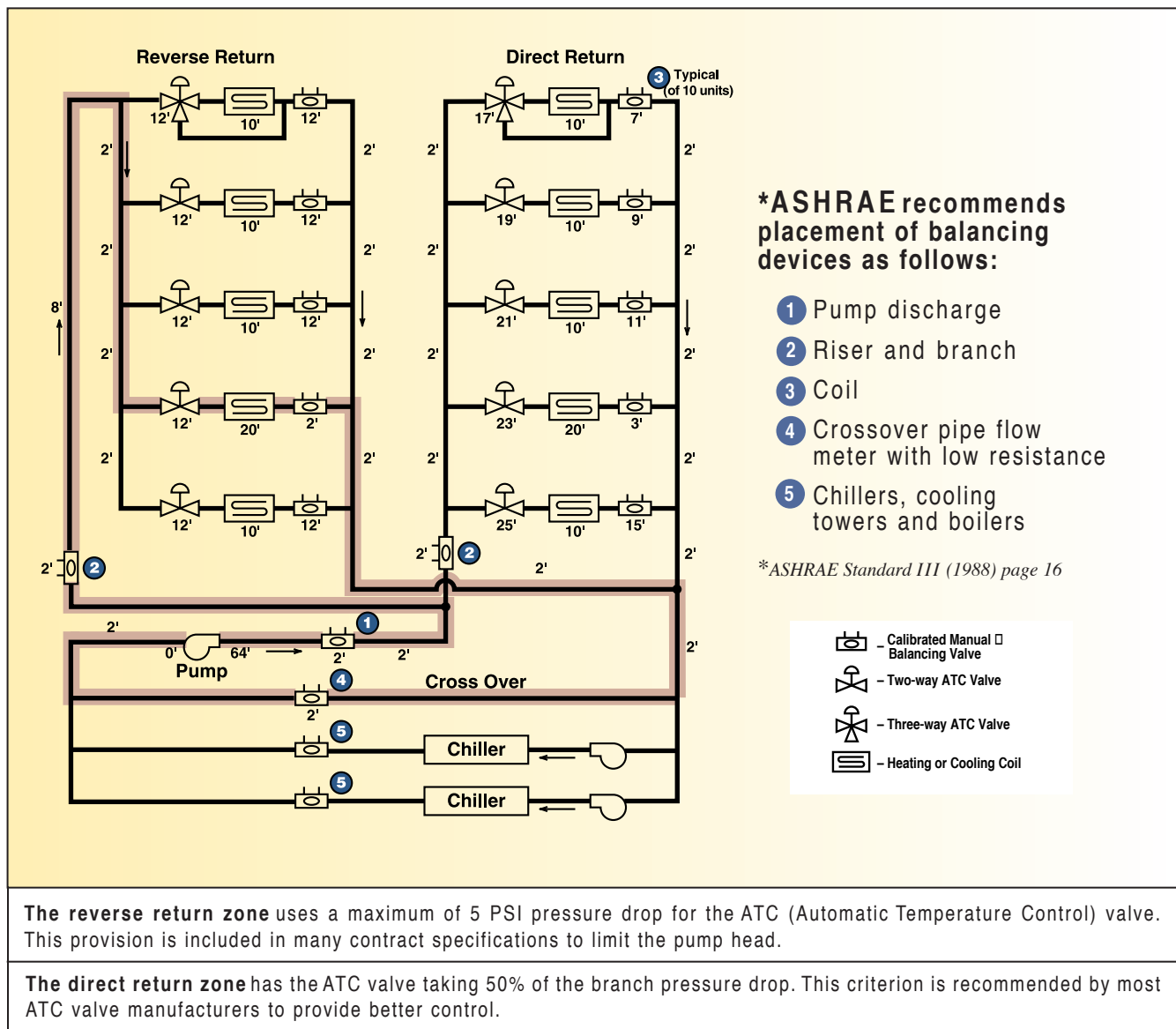

Balancing Valve Locations at a Coil

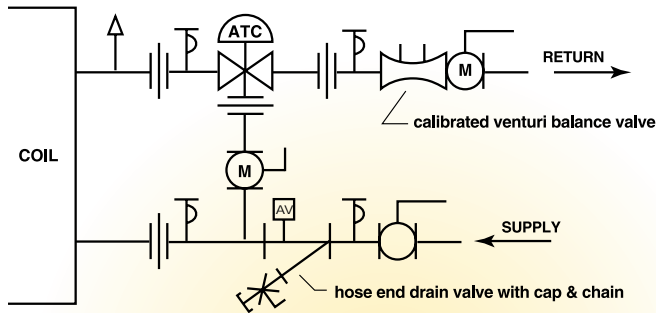

2" AND UNDER
N.C. 3-WAY HEATING AND COOLING COILS

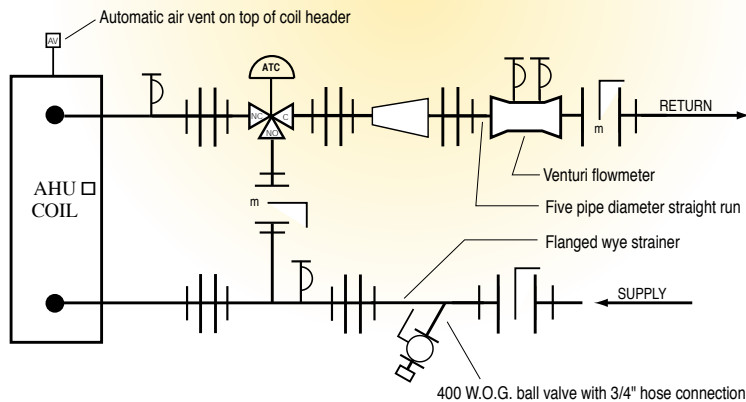

2 1/2" AND LARGER
N.C. 3-WAY HEATING AND COOLING COILS

***ASHRAE recommends locating balancing valves on the return side of the coil to:**

- Minimize air entrapment
- Reduce noise problems
- Decrease the possibility of ATC valve cavitation

*ASHRAE *Systems and Equipment* (1992) Chapter 12.13
Request Report 295A for more information.

NOTES:

- 1) The by-pass line can be the same size as the ATC valve.
- 2) The by-pass line is omitted for 2-way ATC valves.
- 3) On cooling coils, extend the valve handles, P/t ports, air vents and drains to clear insulation.
- 4) On heating coils 2' and smaller, do not insulate the hook-up components.
- 5) Request the "Coil hook-up Design Guide" for more coil schematics.

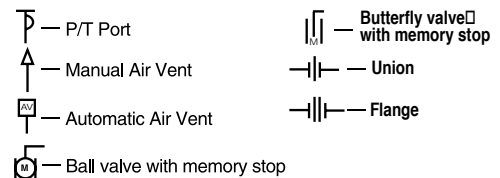

What's Wrong with Circuit Setters?

Circuit setter is a generic industry term used to classify a group of manual balancing valves that perform the three functions: flow measurement, flow adjustment, and shut-off. The cut-away sketch shows the most common configuration. All circuit setters have the following characteristics:

■ Flow is measured based on a gauge reading and the valve handle position. After reading these two variables, a circular slide rule is usually used to calculate the flow.

■ A split opening type insulation box is required so that the handle position can be read. After each use, the box must be reinstalled and taped.

■ Circuit setters require three to ten pipe diameters of straight run on the inlet. This means they cannot be used in compact hook-ups.

■ They have a high pressure loss to flow signal ratio. The permanent loss equals 50% to 90% of the flow signal which adds to the pump head.

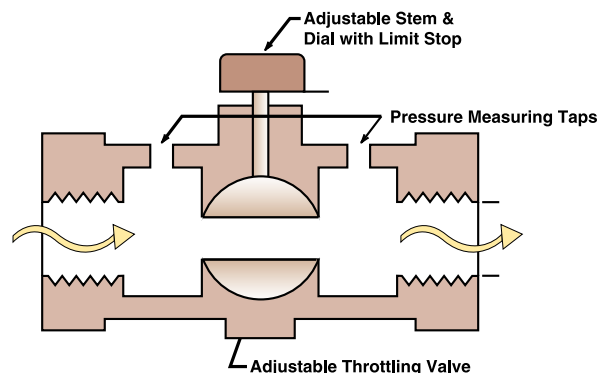

■ Their accuracy is low, $\pm 20\%$. This is due to the turbulence caused by trying to measure differential pressure across a partially open valve.

■ Circuit setters cannot accurately measure flows below one GPM. This is because of the low flow signal they produce when the valve is in the wide open position.

■ Circuit setters are very labor intensive to use because three or four trial settings are required before the desired flow is achieved.

The drawbacks discussed above are eliminated by using AccuSetters. Their unique design and benefits are described on the following pages.

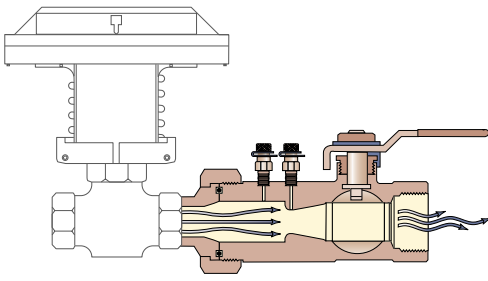

AccuSetter

As shown above, an AccuSetter is suitable for close-coupling to the ATC valve because it has the built-in straight run required and an integral union.

A manual circuit balancing valve performs three functions: flow measurement, flow adjustment, and flow shut-off. Of these, flow measurement is the most important. The three major factors to consider when evaluating a flow measurement device are: accuracy, ease of use, and permanent pressure loss.

High Accuracy

The stated accuracy of Flow Design's AccuSetter is $\pm 3\%$. This accuracy is maintained even while adjustments are being made. By comparison, manufacturers of circuit setters do not state accuracy in their catalogs. Generally, these devices are considered accurate within 10% to 25%. Their accuracy is reduced even further during throttling because of the extreme turbulence across the measurement taps.

About one-half of the balancing measurements are taken with the valve in the wide open position. The typical meter used for balancing is 25 feet full scale. Optimum readability is from two feet to 25 feet, and readings below two feet are very difficult to read accurately. **The balancing valve in the wide open position should produce a flow signal of at least two feet.** Flow Design offers a selection of products that provide higher flow signals for all GPMs.

The table below shows flow signals with the valve wide open for the AccuSetter and several circuit setters. Notice that the AccuSetter provides a strong readable signal (greater than 2 feet) for all flows below 2 GPM. By way of comparison, observe the low signals of the circuit setter types.

Flow Signal for Wide Open Valve

Line Size	Flow GPM	AccuSetter	Armstrong	Taco	B&G
1/2"	0.5	5.2' *	nil	nil	2.0' **
1/2"	1.0	6.3' †	0.2'	0.8'	1.1'
3/4"	1.5	2.2' ‡	0.2'	0.5'	0.7'
3/4"	2.0	4.0' ‡	0.4'	1.0'	1.3'
Highlighted signals are at or greater than recommended 2' minimum			Shaded signals are below the recommended minimum		

* - Model 1/2UL † - Model 1/2L ‡ - Model 3/4L ** - Model RF

Easy Use

With an AccuSetter, the flow can be set in four simple steps. 1) Determine the gauge reading for the design flow using the FDI supplied chart. For example, a 3/4" Model 075H AccuSetter at 5GPM shows 6.3'. 2) Place a suitable gauge on the sensing ports. 3) Adjust the valve handle until the gauge reads 6.3'. 4) Lock the memory stop in place. Job complete!

A circuit setter by comparison does not have a firm gauge reading to achieve 5 GPM because the Cv of the device changes as the throttling valve is closed.

- For this reason, a circular slide rule must be used to calculate the flow based on the combination of meter reading and handle position.

- Insulation must be removed to read the handle position. To allow this, a special insulation box must be provided. The boxes are cumbersome to remove and sometimes are lost. They also limit access to the valve shut-off function.

- The handle position indicator can be difficult to read in poor light and when located in end pockets and overhead ceilings.

- Because two readings are required to obtain flow, two people are often used to balance.

- Many times, three or four combinations of gauge/handle readings must be made to get the design flow.

Benefits



LOW PERMANENT PRESSURE LOSS

Thousands of dollars are saved over the life of a job by using venturi type balancing valves rather than energy wasting circuit setters. The table at the right shows the head and horsepower savings for a typical job.

Generally, three or four wide open manual balancing devices are part of the calculation that determines the maximum pump head. These devices are on the flow path known as the "index circuit" and the proportional balancing technique dictates that they remain open for the life of the job. The permanent pressure losses of these wide open valves add to the total pump head and use additional horsepower. Most engineers who have considered this problem feel that two feet per device should be the maximum pressure loss at design flow in the wide open position.

Another part of the problem is the difficulty of maintaining a strong signal of at least two feet with the valve wide open, so that the balancing contractor can measure the flow with ordinary readout gauges. With common circuit setters, if the signal goes up, so does

The 4" Model AW shown above has extended P/T ports so they will clear insulation. The Model AW is welded into the system, yet allows for valve removal and servicing.

Typical System Pressure Drop for Balancing

System Location	Line Size	AccuSetter	B&G
Pump	4"	0.5'	1.5'
Branch	1 1/4"	0.7'	1.7'
Terminal	3/4"	0.9'	6.0'
	Total	2.1'	9.2'

For each location the pressure drop is less using AccuSetters than using B&G; the total system pressure drop is 7.1 feet less or 2.9 BHP. Using B&G instead of AccuSetters in a 1200 GPM system could cost an additional \$115,000 over the life of a job.

the pressure loss and vice versa. **The solution to this dilemma is to specify a high signal, low loss venturi such as the FDI AccuSetter.** The table below compares the flow signal and permanent loss of the AccuSetter to circuit setters. In almost every size, the circuit setter type has a signal that is too low or a permanent loss that is too high.

Flow Signal and Permanent Pressure Loss with Valve Wide Open[‡]

Manufacturer		AccuSetter		B&G		Armstrong		Taco	
		Signal	Loss	Signal	Loss	Signal	Loss	Signal	Loss
Size	Flow*								
1/2"	2.5	6.3	.9	6.2	4.9	1.4	1.3	4.6	3.3
3/4"	5.0	6.3	.9	7.6	6.0	2.3	2.3	5.4	3.8
1"	10	11.1	1.6	7.0	5.8	1.5	1.4	5.0	3.3
1 1/4"	13	5.8	.7	2.5	1.7	1.5	1.2	2.5	1.3
1 1/2"	18	4.6	.4	1.9	1.3	1.4	1.3	1.5	.9
2"	32	4.0	.5	1.5	1.0	1.8	1.7	1.0	.6
2 1/2"	63	5.1	.9	2.2	1.3	2.0	1.9	1.5	.6
3"	105	4.1	.8	2.0	1.2	2.7	2.7	1.2	.6
4"	220	2.4	.5	1.8	1.5	1.8	1.7	1.2	.6
5"	380	7.3	1.0	1.8	1.8	3.3	3.2	product not available	
6"	620	6.7	1.0	2.1	2.1	4.7	4.4		
8"	1280	9.5	1.3	5.0	5.0	3.0	3.0		
10"	2320	2.8	.9	4.5	4.5	3.0	3.0		
12"	3680	4.6	1.2	6.5	6.5	3.0	3.0		
14"	4800	12	1.7	product not available	product not available	product not available	product not available		

Yellow highlights are flow signals or pressure losses within the acceptable ranges
 Shaded flow signals and pressure losses are out of the recommended ranges. Either the flow signal is less than 2' or the permanent loss is greater than 2'

*Flow rate is 80% of ASHRAE maximum standard.

‡Information obtained from current published material.

How to Select an AccuSetter

1 Review your current specification for “Manual Balancing Valves.” Use a venturi type valve so your client will save energy and obtain the other benefits described on pages 4 and 5. With the specification below as a guide, make sure the highlighted features are in your specification.

A. Manufacturers

1. Flow Design, Inc., FlowSet Models AS, AP, F, AF, AG, AW, EF, EG, & EW

B. Design

1. Manual balancing devices shall be venturi type as recommended by ASHRAE.
2. Devices shall have a precision formed throat and have a stated catalog accuracy of 3% F.S.
3. The induced differential reading (flow signal) shall be greater than two feet water column at the design flow with the valve in the wide open position.
4. The permanent pressure loss at design flow shall not exceed two feet of water in the wide open position.
5. The valves are to have differential readout ports fitted with check valve and protective cap, and are to have a memory stop to allow complete shut-off and return to set position without losing the set-point.

C. Construction

1. All devices shall have a venturi section and a throttling valve with a memory stop on the downstream side of the venturi.
2. The ball valve (sizes 1/2" - 2") shall have a brass or bronze body, blowout-proof stem, virgin teflon seats, brass stem and packing nut and a steel handle.
3. All butterfly valves 2" to 14", shall be cast iron full-lug type, with EPDM seat, 416 s.s. stem, bronze sleeve bearing and an alum./bronze disk.
4. All valves 2" and under shall be factory leak tested at 100 PSI air under water.

D. Minimum Ratings

1. Devices with sweat or NPT connections 1/2" - 2": 400 PSIG at 250°F
2. Devices with flanged connections 2" - 14": 225 PSIG at 250°F

E. Readout Meter Kit

- Provide a portable readout meter kit by the manufacturer of the balancing devices.
1. The meter shall be housed in a durable case complete with two 10' color coded hoses with shut-off valves at the end that connects to the balance valve so that water does not drain out between readings.
 2. Meter shall have a 6" diameter face with 270° needle travel and ±1.75% full scale accuracy.
 3. Meter shall be provided with a removable transparent face indicating flow directly in GPM for each size device furnished (1/2" - 2").
 4. Meter shall have a forged brass body and a three-valve manifold for over-range protection.
 5. Meter shall have a dual scale reading inches and feet W.C..
 6. Meter shall be equal to Flow Design Model 300.4.

F. Installation

1. The straight pipe required to achieve 3% F.S. accuracy shall be incorporated as an integral part of the 1/2" to 2" venturi and valve assembly. Five pipe diameters of straight pipe is required from a control valve for sizes 2 1/2" to 14" venturis.
2. Install balancing valves on the return lines of the coils as recommended by ASHRAE.
3. Install in accordance with the manufacturer's instructions.
4. Check connections after installation for leaks.

2 Review your coil piping schematic to make sure the detail reflects the following:

- The balancing valve is located on the return side of the coil per ASHRAE recommendations.
- There are adequate unions, P/T ports and air venting.
- A Y-strainer with a blowdown is located on the coil inlet to protect the coil, ATC valve and balancing valve from debris.

Use the coil details on page 3 as a guide or refer to the FDI “Coil Hook-Up Design Guide,” Bulletin F007.

3 Specify the coil runout pipe sizes. Refer to the ASHRAE recommendations shown in the chart below. Some designers prefer to use 80% of the ASHRAE maximum.

ASHRAE Recommended Maximum GPM

Nominal Size	1/2"	3/4"	1"	1 1/4"	1 1/2"	2"	2 1/2"	3"	4"	5"	6"	8"	10"	12"	14"	
Type L Copper	2.8	5.9	10	16	23	39	78	130	270	—	—	—	—	—	—	
Schedule 40 Pipe	3.8	6.5	11	18	25	41	72	130	275	475	775	1600	2900	4500	6000	
ASHRAE Criteria	Maximum Velocity: 4ft./sec.						Maximum loss: 4ft./100 ft.									

4 Select the valve size using the chart below. Select a model where the design GPM falls between the high and low ranges shown on the sizing chart. By using this chart, the minimum signal on the readout gauge will be 2 feet and the pressure loss will not exceed 2 feet.

AccuSetter GPM Ranges and Flow Factors

Brass Body Models:

Pipe Size	1/2"			3/4"		1"	1 1/4"	1 1/2"	2"	2 1/2"
AccuSetter Size	050UL	050L	050H	075L	075H	100	125	150	200	250
Low Flow (2'ΔP)	1.3	0.5	1.4	1.4	2.8	4.2	7.6	12	23	38
High Flow (20'ΔP)	1.0	1.8	4.5	4.5	9.0	13.5	24	38	72	120
Flow Factor (FF)	1.1	2	5	5	10	15	27	42	80	135

Steel Body Models:

Pipe Size	2"		2 1/2"		3"		4"		5"	
AccuSetter Size	200L	200H	250L	250H	300L	300H	400L	400H	500L	500H
Low Flow (2'ΔP)	25	44	39	88	74	151	133	201	196	490
High Flow (8.3'ΔP)	50	90	87*	180	150	310	270	410	485*	1000
Flow Factor (FF)	86.6	156	139	312	260	537	468	710	693	1730
Pipe Size	6"		8"		10"		12"		14"	
AccuSetter Size	600L	600H	800L	800H	1000L	1000H	1200L	1200H	1400L	
Low Flow (2'ΔP)	343	980	695	1350	880	1960	1470	2450	1960	
High Flow (8.3'ΔP)	975*	2000	1420	2750	1800	4000	3000	5000	6000*	
Flow Factor (FF)	1210	3465	2456	4765	3118	6930	5200	8660	6930	

Notes: ΔP = Flow Signal = Gauge Reading

Permanent Loss = 10% of Flow Signal—(See page 5)

*250L = 117" ΔP; 500L = 147" ΔP; 600L = 194" ΔP; 1400L = 224" ΔP

Ask for bulletins F192 and F193 for a complete range of ΔP vs. GPM

Formula to complete exact ΔP or GPM	$\Delta P \text{ (feet)} = \left[\frac{\text{GPM} \times 5}{\text{FF}} \right]^2$	$\text{GPM} = \frac{\text{FF}}{5} \times \sqrt{\Delta P} \text{ (feet)}$
-------------------------------------	--	--

EXAMPLE 1 Select the AccuSetter size for 1.5 GPM design flow.

The chart shows three valve sizes where 1.5 GPM is between the low and high flows: 050L, 050H and 075L. If the runout pipe is 3/4", select 075L. If the runout is 1/2" there is a choice between 050L and 050H.

The best choice is generally the valve where the design flow is closest to the low end of the range. This will minimize the permanent pressure loss. On that basis, select 050H.

EXAMPLE 2 Compare the gauge reading and permanent loss for Models 050H and 050L at 1.5 GPM. Use the formula in the chart above to calculate the exact ΔP (gauge reading in feet).

Model 050H

$$\Delta P = \left[\frac{\text{GPM} \times 5}{\text{FF}} \right]^2 = \left[\frac{1.5 \times 5}{5} \right]^2 = 2.25 \text{ feet.}$$

The permanent pressure loss is 10% of the gauge reading or .22 feet.

Model 050L

$$\Delta P = \left[\frac{\text{GPM} \times 5}{\text{FF}} \right]^2 = \left[\frac{1.5 \times 5}{2} \right]^2 = 14 \text{ feet.}$$

The permanent pressure loss is 10% of the gauge reading or 1.4 feet.

5

Select the AccuSetter type.

Brass Body Models

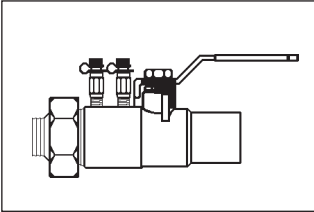

Model AP - 1/2" to 2 1/2"

Combination venturi, ball valve and union. High signal, low loss venturi section has $\pm 3\%$ accuracy. It has bronze and brass construction and is rated for 400 PSIG at 250°F. Schrader type access ports are standard, temperature/pressure ports optional. Flow lock memory stop allows shut-off and resetting without losing the balance set point. One or two size reductions on the union tailpiece are available to ease threading directly into the ATC valve. See Bulletin F094 for more details.

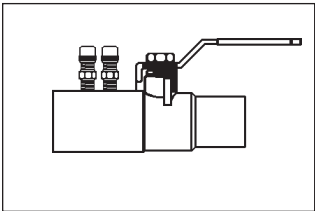

Model AS - 1/2" to 2 1/2"

Combination venturi and ball valve. High signal, low loss venturi section has $\pm 3\%$ accuracy. It has bronze and brass construction and is rated for 400 PSIG at 250°F. Schrader type access ports are standard, temperature/pressure ports optional. Flow lock memory stop allows shut-off and resetting without losing the balance set point. See Bulletin F096 for more details.

Steel Body Models

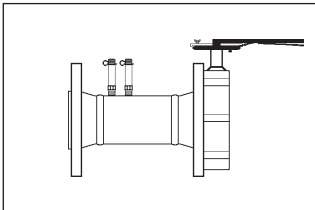

Models AF & EF - 2" to 14"

Model includes a 150# flanged-end venturi with a lug butterfly valve attached to the downstream side. Pressure access ports are standard. Also, an ten-position handle with memory stop through 6" with a gear operator 8" and up is standard. The assembly meets "Buy America" guidelines. The model EF has a five diameter inlet extension added to the model AF which provides adequate straight run when close coupled to control valves or pumps. See bulletins F212 (AF) or F218 (EF) for more details.

- Field installation requires two 150# mating flanges, nuts and bolts. The cap screws to mate with the butterfly are included.

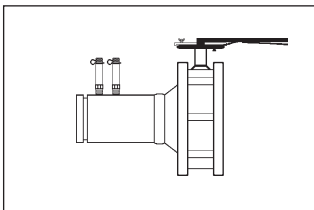

Models AG & EG - 2" to 14"

Model includes a grooved venturi on the entry with a lug butterfly valve mounted on the downstream exit end and a 150# grooved flange adapter, supplied loose, for attachment to the butterfly valve and downstream grooved pipe. Pressure access ports are standard. Also, an ten-position handle with memory stop through 6" with a gear operator 8" and up is standard. The assembly meets "Buy America" guidelines. The unit is shown with optional P/T ports. The model EG has a five diameter inlet extension added to the model AG which provides adequate straight run when close coupled to control valves or pumps. See bulletins F212 (AG) or F218 (EG) for more details.

- Field installation requires one standard grooved coupling for the upstream attachment.

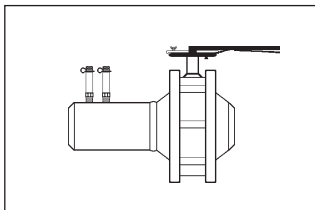

Models AW & EW - 2" to 14"

Model includes a weld-end venturi on the inlet with a lug type butterfly valve mounted to the downstream venturi flange, and a 150# weld-end flange mounted to the butterfly valve. Pressure access ports are standard. Also, an ten-position handle with memory stop through 6" with a gear operator 8" and up is standard. The assembly meets "Buy America" guidelines. The unit is shown with optional P/T ports. The model EW has a five diameter inlet extension added to the model AW which provides adequate straight run when close coupled to control valves or pumps. See bulletins F212 (AW) or F218 (EW) for more details.

- Field installation requires no additional material.



8908 Governors Row
Dallas, Texas 75247
800-ASK-FLOW
FAX 214-631-0735

Represented by:

Form No: F098.4
Date: 6.97
Supersedes: F098.3