

Model FD-110 Types A & B

Narrowline Construction

1 1/2 Hour Fire Resistance Rating

APPLICATION

Model FD-110 is approved for use in walls, floors and partitions with fire resistance ratings less than 3 hours. This model carries a 1 1/2 hour UL fire damper label. UL 555 classifies static rated fire dampers for use in HVAC systems that are automatically shut down in the event of fire.

CONSTRUCTION

Galvanized steel (in gauges required by UL listing R-13317)

INSTALLATION

All fire damper installations require the use of sleeves, angles and methods described in Greenheck Fire Damper Installation Instructions #452763, included with every damper shipment. Sleeves can be field fabricated or factory furnished as a complete damper/sleeve assembly. See Factory Sleeve Option below for details.

Model FD-110 meets the requirements for fire dampers established by:

National Fire Protection Association
(NFPA Standards 90A & 101)

Underwriters Laboratories Standard 555 (Listing #R-13317)

BOCA National Building Codes

ICBO Uniform Building Codes (UBC Standard 43-7)

SBCCI Standard Building Codes

New York City (MEA listing #260-91-M)

California State Fire Marshall
(Listing #3225-981:102 for use in walls)

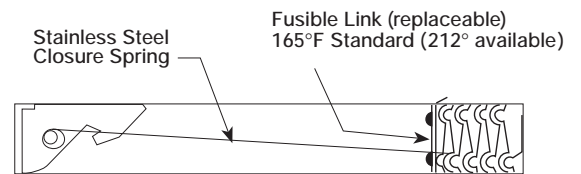
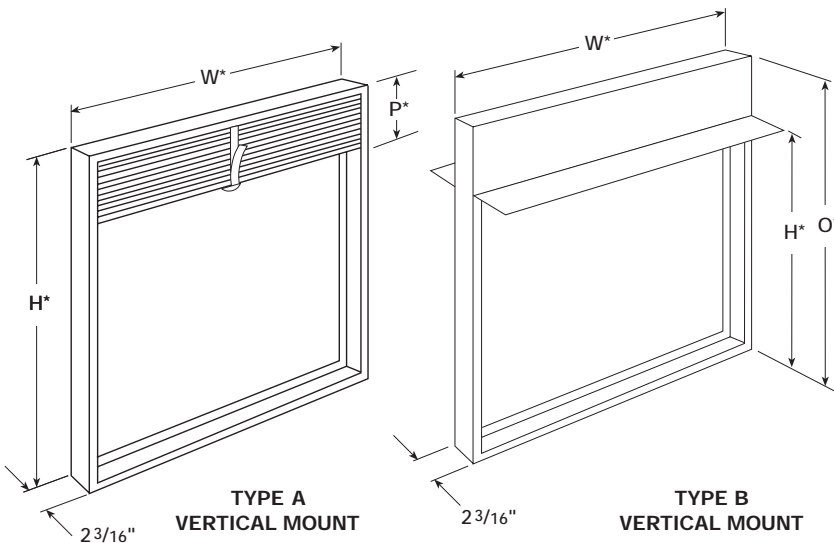

HORIZONTAL MOUNT

* These dimensions are furnished approximately 1/4" undersize

FACTORY SLEEVE OPTION

FD-110 Fire Dampers are available in factory furnished sleeves. Sleeves are galvanized steel and are available in 10 thru 20 ga. thicknesses and lengths up to 36".

"K" dimension specifies location of damper within the sleeve. Minimum is 4", maximum is "L" less 4", which allows for mounting angle installation and duct connection at each end of sleeve. If "K" dimension is not specified, it will be provided as one half of "L" dimension (damper centered in sleeve).

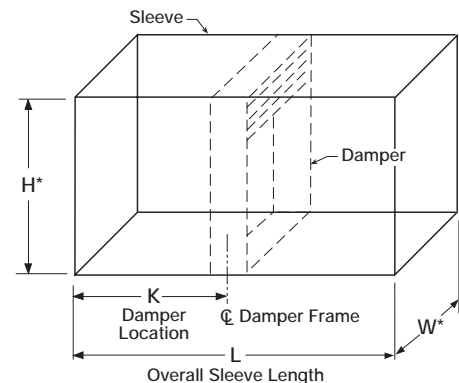

Qty.	Type A B	Mount (V)Vert. (H)Horz.	Damper Size		Fusible Link Temp (165°F std.)	Factory Sleeve Option					
			W*	H*		Dimensions		Gauge	Material		
						L	K				
Project						Location					
Contractor						Design Specifier					

FD-110 Types A & B

SIZING DATA

Narrowline FD-110 models are normally supplied in single section sizes only.

Vertical or Horizontal Mount		
	Type A	Type B
Minimum	4"x 4"	4"x3"
Maximum	48"x48"	48"x43"

Type A - Maximum Dimensions

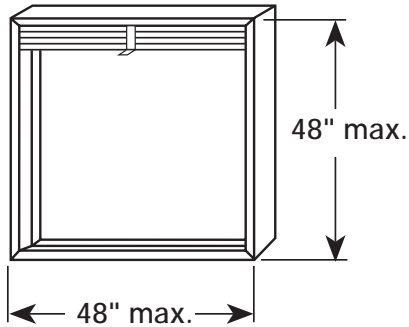

Type B - Maximum Dimensions

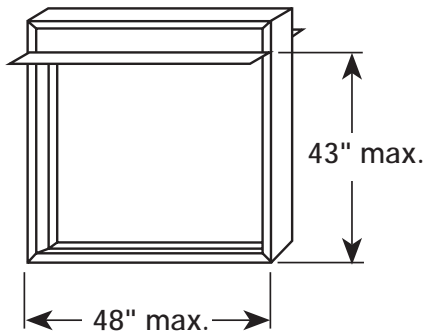

Overall Damper and Blade Stack Dimensions

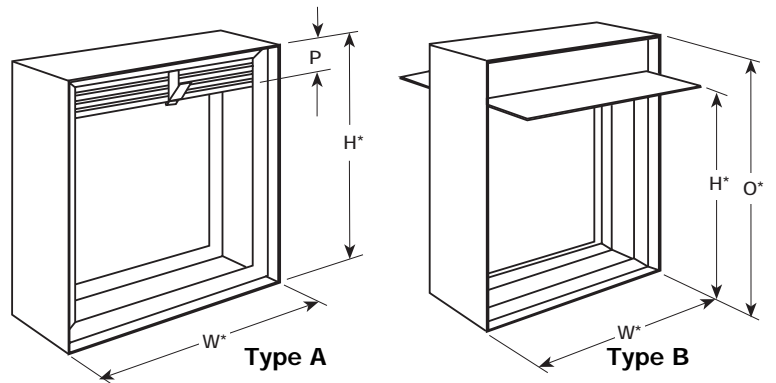

H*	P	O*
3"	-	5"
4	0.8"	6
5	0.8	7
6	0.9	8
7	1.1	9
8	1.2	10
9	1.3	11
10	1.3	12
11	1.4	13
12	1.6	14
13	1.7	15
14	1.8	16
15	1.8	18
16	2.0	19
17	2.1	20
18	2.2	21
19	2.3	22
20	2.4	23
21	2.6	24
22	2.6	26
23	2.7	27
24	2.9	28
25	3.1	29
26	3.2	30
27	3.2	31
28	3.3	32
29	3.4	33
30	3.6	34
31	3.7	35
32	3.7	36
33	3.9	38
34	3.9	39
35	4.1	40
36	4.2	41
37	4.2	42
38	4.4	43
39	4.4	44
40	4.6	45
41	4.7	46
42	4.8	47
43	5.0	48
44	5.0	-
45	5.2	-
46	5.3	-
47	5.3	-
48	5.5	-

* These dimensions are furnished approximately 1/4" undersize

