

Application and Design

ESU-150 is a Thin-Line stationary louver commonly used for interior or exterior applications where high free area and low airflow resistance is required. The narrow frame depth and various frame options make them ideal products for installation into curtainwall, windows, door louvers and as air conditioning grilles.

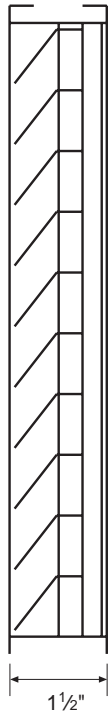

Standard Construction

- Frame: 6063T5 extruded aluminum, 1 1/2" x 0.063" nominal dimensions
- Blade: Thin-Line style, 6063T5 extruded aluminum, 0.063" nominal wall thickness, positioned at 52° angles on 3/4" centers
- Birdscreen: 3/4" x 0.051" flattened expanded aluminum in a removable frame, screen is mounted on inside (rear)
- Finish: Mill
- Minimum Size: 13.5"W x 10"H - without Flange
13.5"W x 12"H - with Flange
- Maximum Single Section Size: 96"W x 48"H

Options (at additional cost)

- Extended sill
- Flanged frame
- Captivated frame
- Glazing frame
- A variety of bird and insect screens
- A variety of architectural finishes including:
 - Clear anodized
 - Integral color anodized
 - Baked enamel
 - Kynar

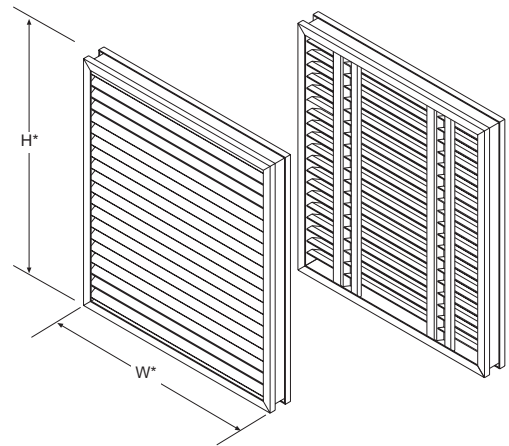

FRONT VIEW

BACK VIEW

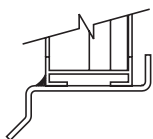

EXTENDED SILL

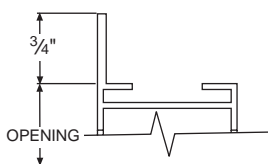

FLANGED FRAME

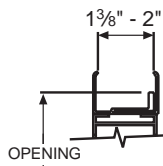

CAPTIVATED FRAME

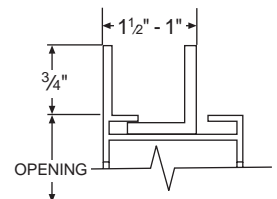

GLAZING FRAME

* W & H Dimensions furnished approximately 1/4" under size.

Quantity	Size		Frame Type	
	W Width	H Height		
Project			Location	
Contractor			Architect/Engineer	

ESU-150 Louver Performance Data

Free Area Chart

Louver Height Inches	Louver Width in Inches																Louver Height Inches
	10	12	18	24	30	36	42	48	54	60	66	72	78	84	90	96	
10	0.18	0.24	0.41	0.6	0.78	0.97	1.15	1.34	1.47	1.66	1.84	2.03	2.23	2.34	2.53	2.72	10
12	0.22	0.3	0.51	0.74	0.97	1.2	1.43	1.67	1.83	2.06	2.29	2.52	2.78	2.92	3.15	3.38	12
15	0.28	0.38	0.66	0.95	1.25	1.55	1.85	2.14	2.35	2.65	2.95	3.25	3.58	3.75	4.05	4.35	15
18	0.35	0.47	0.8	1.17	1.53	1.89	2.26	2.62	2.88	3.24	3.61	3.97	4.38	4.59	4.95	5.32	18
21	0.41	0.55	0.95	1.38	1.81	2.24	2.67	3.1	3.41	3.83	4.26	4.7	5.17	5.43	5.86	6.29	21
24	0.47	0.64	1.1	1.59	2.09	2.59	3.08	3.58	3.93	4.43	4.92	5.42	5.97	6.27	6.76	7.26	24
27	0.54	0.72	1.24	1.81	2.37	2.93	3.5	4.06	4.46	5.02	5.58	6.15	6.77	7.11	7.67	8.23	27
30	0.6	0.81	1.39	2.02	2.64	3.27	3.9	4.53	4.97	5.6	6.23	6.86	7.56	7.93	8.56	9.18	30
33	0.66	0.89	1.53	2.23	2.92	3.62	4.31	5.01	5.5	6.19	6.89	7.58	8.36	8.77	9.46	10.16	33
36	0.72	0.98	1.68	2.44	3.2	3.96	4.72	5.49	6.02	6.78	7.54	8.31	9.16	9.61	10.36	11.13	36
39	0.79	1.06	1.83	2.65	3.48	4.31	5.14	5.96	6.55	7.37	8.2	9.03	9.96	10.44	11.27	12.1	39
42	0.85	1.15	1.97	2.87	3.76	4.65	5.55	6.44	7.08	7.97	8.86	9.76	10.76	11.28	12.17	13.07	42
45	0.91	1.23	2.12	3.08	4.04	5	5.96	6.92	7.6	8.56	9.52	10.48	11.55	12.12	13.08	14.04	45
48	0.98	1.32	2.27	3.29	4.32	5.34	6.37	7.4	8.13	9.15	10.18	11.21	12.35	12.96	13.98	15.01	48

Louver Free Area in Square Feet

Airflow Resistance (Standard Air - .075 lb/ft³)

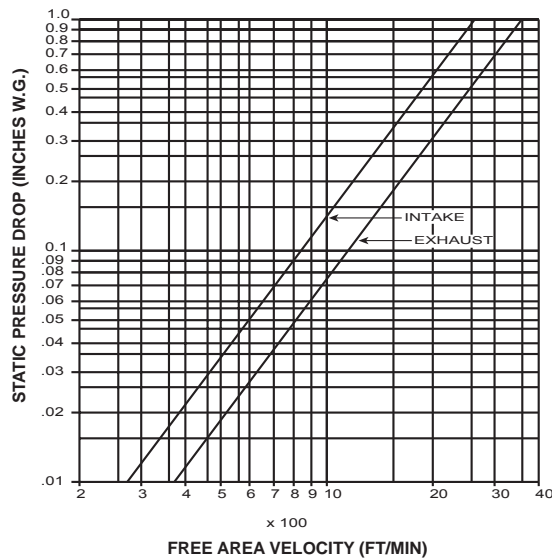

Typical Details

