



ENERGY RECOVERY VENTILATOR

- Commercial
- Institutional



MODEL ERV



February 2000

ENERGY RECOVERY VENTILATOR



VENTILATE ADEQUATELY AND ECONOMICALLY

To provide a healthy and productive indoor environment, adequate ventilation is necessary. ASHRAE Standard 62, Ventilation for Acceptable Indoor Air Quality, prescribes ventilation requirements. However, providing adequate ventilation AND controlling energy costs may appear to be mutually exclusive objectives. Greenheck recognized this dilemma and accepted the challenge of developing ventilation equipment that enables an HVAC system to meet both objectives.

The result is the Greenheck Energy Recovery Ventilator, which allows the HVAC system to meet the Standard 62 ventilation rates while controlling energy costs and humidity levels. This product line offers the system designer an economical solution to many Indoor Air Quality problems. In many markets payback is less than one year. Additionally, Greenheck's energy recovery ventilators are easy to apply in new construction or renovation installations.

IDEAL FOR:

- Schools
- Office Buildings
- Nursing Homes
- Retail Stores
- Restaurants
- Hotels

ENERGY RECOVERY TECHNOLOGY

Greenheck has combined its expertise in ventilation products with the latest technology in air-to-air heat exchangers. The heart of the energy recovery ventilator is a light-weight polymer enthalpy wheel. Silica gel desiccant is permanently bonded to the polymer, which provides a long and reliable energy transfer life. This state of the art wheel design has low pressure drop characteristics that enable the ventilator to accommodate external static pressure requirements up to 1.50 in. wg. Also, in contrast to heat wheels of the 1970's, Greenheck's wheels were designed specifically for commercial and institutional installations with minimal maintenance in mind. For comfort ventilation applications up to 9,000 cfm, it is the best all around total energy recovery device available.



UL Listed - Ducted Heat Recovery Ventilators

C



For more information on Greenheck's Energy Recovery products see our web site at www.greenheck.com.



Greenheck certifies that the ERV models shown herein are licensed to bear the AMCA seal. The ratings shown are based on tests and procedures performed in accordance with AMCA publication 211 and comply with the requirements of the AMCA Certified Ratings Program.

The basic objectives for providing acceptable Indoor Air Quality are to control indoor contaminant levels while maintaining desired indoor air temperature and humidity. Compliance with the prescribed ventilation rates in ASHRAE Standard 62 appear to satisfy the contaminant issue. However, simply increasing outdoor air requirements with "traditional" HVAC systems may not address the humidity issue properly and often leads to significant energy cost increases.

The best solution for most commercial and institutional facilities will include an enthalpy wheel product. These products transfer temperature and moisture properties from one airstream to another. The result is capturing the cooling or heating energy from the exhaust air before it leaves the HVAC system. This product concept and its energy transfer capabilities are illustrated below.

SUMMER

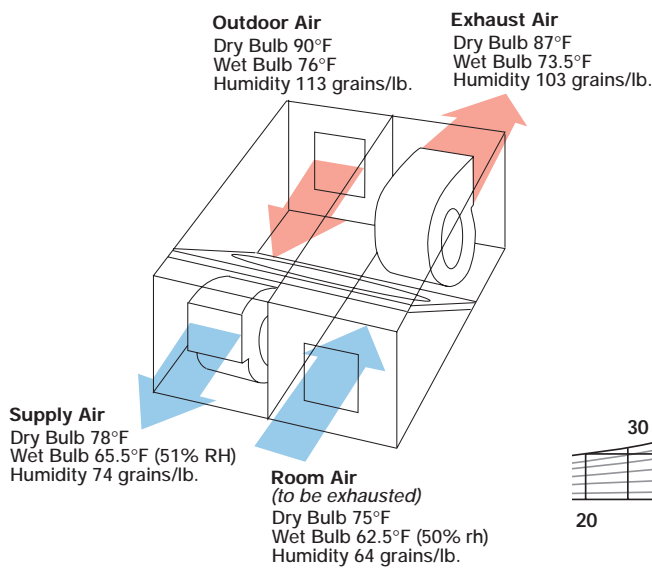

- Cools outdoor air with up to 85% effectiveness of sensible heat transfer.
- Extracts moisture from outdoor air with up to 85% effectiveness of latent energy transfer.
- Reduces ventilation cooling load up to 4 tons per 1000 cfm.

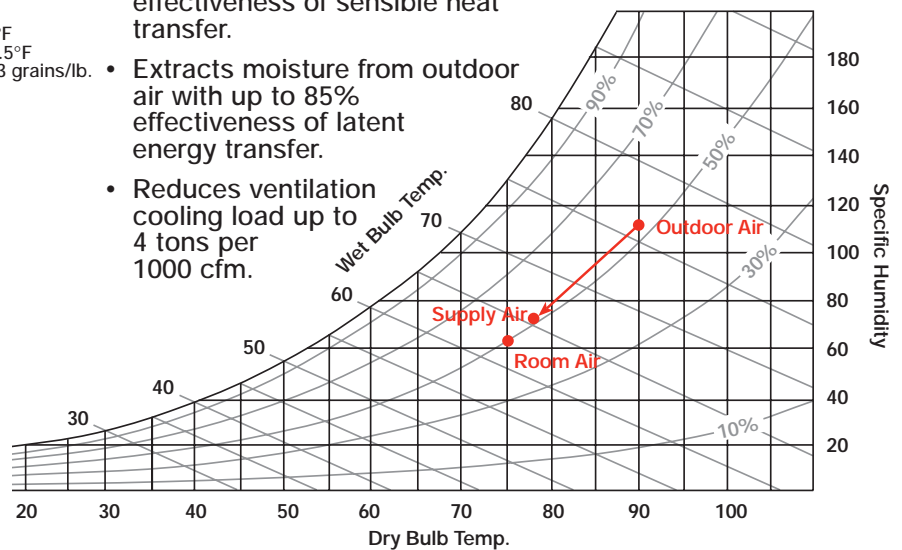

WINTER

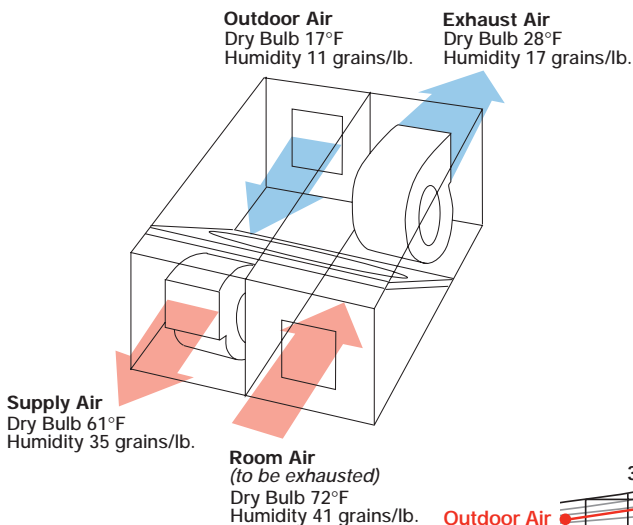

- Heats outdoor air with up to 85% effectiveness of sensible heat transfer.
- Adds moisture to outdoor air with up to 85% of latent energy transfer.
- Reduces heating and humidification costs by up to 60,000 Btuh per 1000 cfm at design temperature.

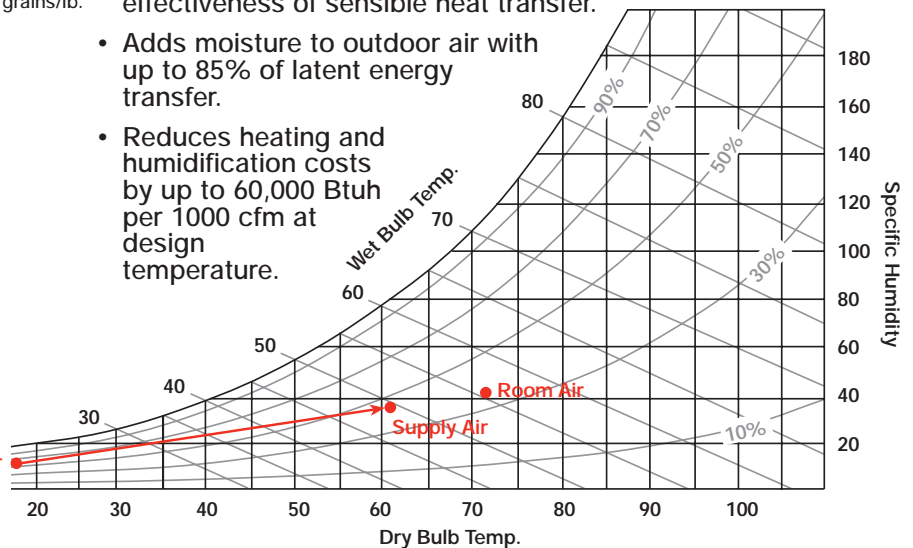

The Greenheck ERV product line provides complete airflow performance coverage from 400 cfm to 9,000 cfm. Four product arrangements offer installation flexibility for both interior and exterior applications (see page 5). For maximum performance flexibility, energy recovery wheels are either Standard (S) airflow for highest efficiency or High (H) airflow for lowest first cost (see pages 8 & 9).



All models include the latest technology for air to air energy transfer. Light-weight polymer energy transfer wheels with a permanently bonded silica gel coating that are up to 85% effective, require minimal maintenance and are a key contributor to economically priced energy recovery ventilators. Standard features are listed below.

FEATURES OF GREENHECK ERV PRODUCTS

- Licensed to bear the AMCA seal for Air Performance.
- Enthalpy wheel for recovering both sensible and latent energy. (Sensible only wheel optional).
- Energy recovery wheel with long, reliable life.
- Quiet running, forward curved blowers.
- Housing lined with foil faced insulation.
- Adjustable motor pulleys for final system balancing.
- All internal electrical components are factory wired. Motor starters and disconnect switch are standard.
- Neoprene isolation on motor/blower assembly to minimize noise transmittance to building is standard.
- Compact housing and multiple ducting arrangements for maximum design flexibility.
- All exterior arrangements are provided with intake and exhaust hoods as standard.

These product features contribute to the key benefits of low maintenance, effective control of humidity and economical IAQ solutions.

LOW MAINTENANCE

Proper maintenance is the key to extending the life of any component within an HVAC system.

One way to help assure that maintenance is done properly is to minimize the work involved for the people who perform it. With this in mind, we designed our energy recovery ventilators so that minimal maintenance is required. Here's how:

- Removable side or hinged panels provide easy access to energy wheel, blowers, motors and drive components.
- Wheel cassette slides out easily for inspection and maintenance.
- Wheel sections are easily removed, without tools for periodic cleaning.
- Filters are readily accessible.
- Moisture is transferred entirely in the vapor phase to eliminate the requirement for condensate drains.
- Light weight polymer enthalpy wheel contributes to low shaft and bearing loads, resulting in reliable, long life operation.



BENEFITS

ECONOMICAL SOLUTION

Low first cost and maximum energy savings combine to yield an extremely attractive payback on Greenheck Energy Recovery Ventilators. By incorporating ERVs into the HVAC system, air conditioning and heating equipment can be downsized considerably. In hot and humid climates the energy recovery ventilator cost is offset by the avoided increase in air conditioning equipment cost and payback is immediate. In many other climates, payback is typically less than one year.

HUMIDITY CONTROL

Humidity is an important factor to consider for providing comfortable room conditions and a healthy environment. Additionally, controlling humidity levels can prevent building asthmatic and structural problems. More than 75% of all IAQ problems start with comfort complaints. If these are not addressed, employees will continue to complain and become less productive. From the health perspective, humidity levels that are too high may promote growth of mold, bacteria, viruses and fungi. Low humidity may cause irritation and increase respiratory symptoms.

Energy recovery ventilators are perfectly suited to help control humidity. In the summer, when outdoor humidity is high, the energy wheel dehumidifies the outdoor air. This greatly reduces the latent load on the air conditioning equipment and also eliminates rising indoor humidity levels that can occur in hot, humid climates. In the winter, when outdoor air is dry, the energy wheel humidifies the outdoor air. This increases comfort and reduces the amount of humidification required.

ARRANGEMENT A - INTERIOR MOUNTED

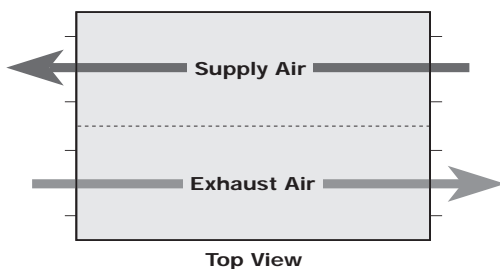

Fig. 1

ARRANGEMENTS

INTERIOR

This compact design is ideal for the space limitations that routinely complicate interior installations.

ARRANGEMENT A

Specify arrangement A for interior mounting. All ERV sizes are available in this arrangement. Fig. 1 below is typical for ERV-251, ERV-361, ERV-521 and ERV-581.

EXTERIOR

Where roof mount or pad mount installations are preferred, Greenheck offers three arrangements to provide the flexibility to simplify system design and installation. Louvered intake hood and an exhaust hood are standard on arrangements B, C and D. The housing and hood design minimize re-entrainment of exhaust air.

ARRANGEMENT B

Ideal for roof mount installations where both exhaust and supply ducts penetrate the roof deck and attach to the bottom of the energy recovery ventilator. Fig. 2 below is typical for ERV-251, ERV-361, ERV-521 and ERV-581.

ARRANGEMENT C

Ideal for roof mount installations where the supply airstream is to be routed directly into a rooftop HVAC unit. Exhaust air enters the ERV from below.

ARRANGEMENT D

Suited for pad mounting, where both the exhaust and supply duct connects to the side of the ERV.

Reference pages 12 and 13 for arrangement drawings and dimensions.

ARRANGEMENT B - ROOF MOUNTED

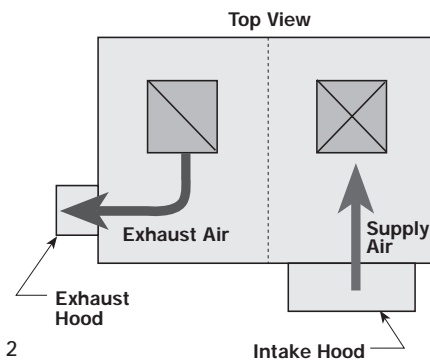

Fig. 2

Energy Recovery Ventilators may be applied in many HVAC installations. Integrating the energy recovery ventilator into the air conditioning duct system is a common installation. This approach enables the specifying engineer to use the same basic design as traditional HVAC systems, but with the savings provided by energy recovery. The main modifications, as compared to traditional systems, simply involve routing fresh outdoor and stale exhaust air through the energy recovery ventilator. In most cases, additional ductwork is minimal.

This means of providing adequate outdoor air to the occupied spaces is the same in concept no matter how the air conditioning equipment is configured. Since the energy recovery ventilator and air conditioning equipment are integrated, or coupled together, the appropriate amount of fresh outdoor air is provided whenever the air conditioning equipment is operating.

There are many system configurations that utilize this concept. Two sample installations are shown below.

WITH PACKAGED ROOFTOP EQUIPMENT

The drawing at right illustrates how energy recovery ventilators may be used in conjunction with packaged rooftop equipment. Fresh, outdoor air enters the energy recovery ventilator and is pre-treated before entering the heating / cooling equipment. The energy source for pre-treating the outdoor air is the portion of the return air to be exhausted through the energy recovery ventilator.

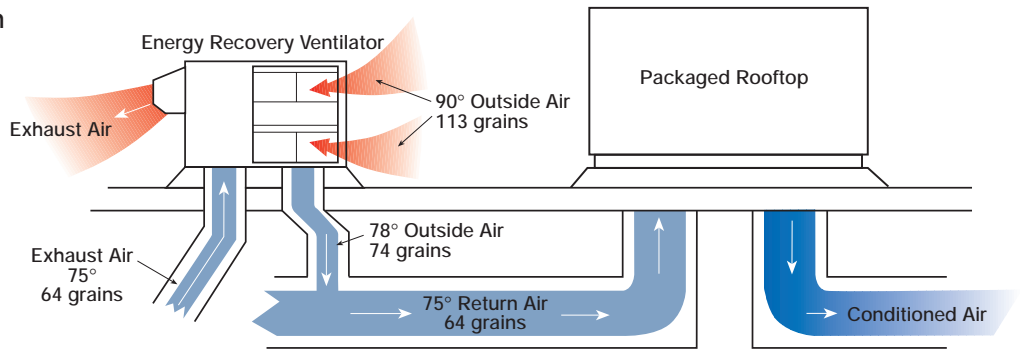

WITH DUCTED AIR HANDLERS

Energy recovery ventilators may also be used in conjunction with ducted air handling units or fan coil boxes. A single energy recovery ventilator may provide fresh outdoor air for multiple air handling units

(as shown below) or in a one-to-one ratio where a single energy recovery ventilator and air handler serves only one space. For additional design flexibility, the energy recovery ventilator may also be duct mounted.

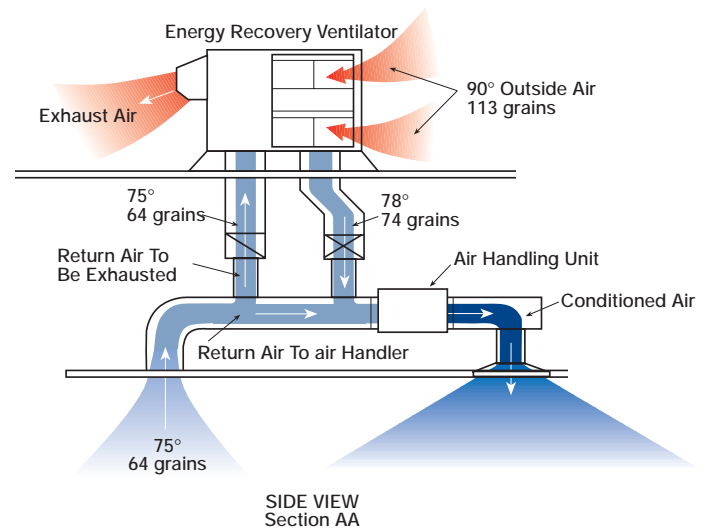
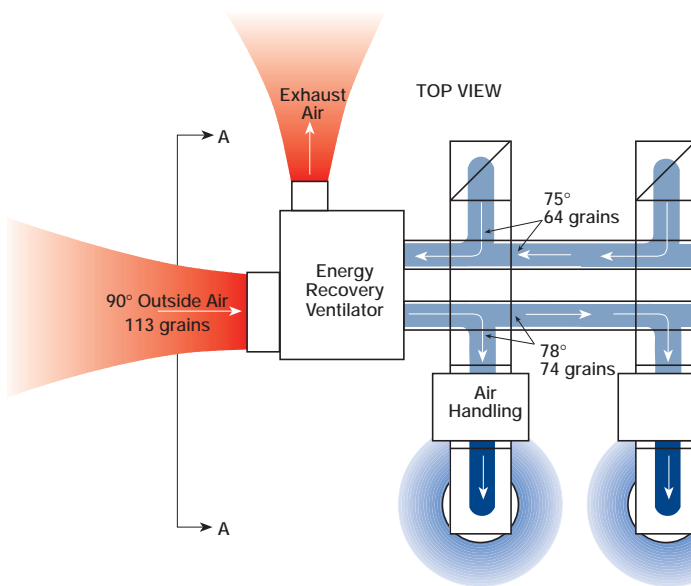

The drawing above shows the plan view of a single energy recovery ventilator providing fresh outdoor to multiple air handling units.

The above drawing shows the elevation view of the energy recovery ventilator and air handler in an integrated duct system.

LIMITATIONS TO INTEGRATED SYSTEMS

The integrated system concept provides the simplest, lowest cost application for ERVs when the outdoor air to total supply air percentage (i.e., 25%) is the same for all spaces. However, when a single HVAC unit services multiple spaces where outdoor air requirements (as a percent of total supply air) differ significantly, the integrated system is not the best approach.

An example may help illustrate this concept. Assume that a packaged rooftop unit serves an office building and provides supply air that is made up of 25% outdoor air and 75% return. Employee A, in an office with a high thermal load, receives 200 cfm of supply air which

includes 50 cfm of outdoor air. Employee B, in an office with a low thermal load, receives only 40 cfm of supply air which includes just 10 cfm of outdoor air. In this example, employee A receives far more than the 20 cfm per person prescribed by ASHRAE Standard 62-1989, which translates into higher energy and equipment costs to condition the extra 30 cfm. Conversely, employee B received far less than the Standard prescribes, which translates into lower productivity and potential lawsuits.

In cases as described above, integrated systems are unable to effectively address both the indoor air quality and energy conservation issues.

THE DE-COUPLED SYSTEM

De-coupled systems should be strongly considered where thermal loads vary significantly from space to space. The de-coupled concept uses a dedicated system for ventilation air delivery, which allows independent control of ventilation air and thermal conditioning. The air conditioning equipment processes 100% return air and supplies it back to the occupied space. Exhausting stale air and supplying fresh outdoor air is handled by the energy recovery ventilator.

For multiple space applications where outdoor air requirements (%) vary significantly from space to space, the de-coupled system has the following advantages:

- Adequate outdoor air is supplied to all occupied spaces.

- Compliance with ASHRAE Standard 62 for all spaces can be easily demonstrated.
- Requires the lowest total outdoor air quantities, which results in the lowest energy consumption.
- Provides the lowest initial cost in most cases.

Applying the de-coupled system with energy recovery makes a good concept great. The energy recovery ventilator conditions the outdoor air to temperature and humidity values at, or near, room conditions. Depending on the climate and preference of the specifying engineer, supplemental heating or cooling for the ventilation air may not be necessary. If supplemental heating or cooling is desired Greenheck's Model ERT should be considered.

The drawing below illustrates the de-coupled design concept with energy recovery.

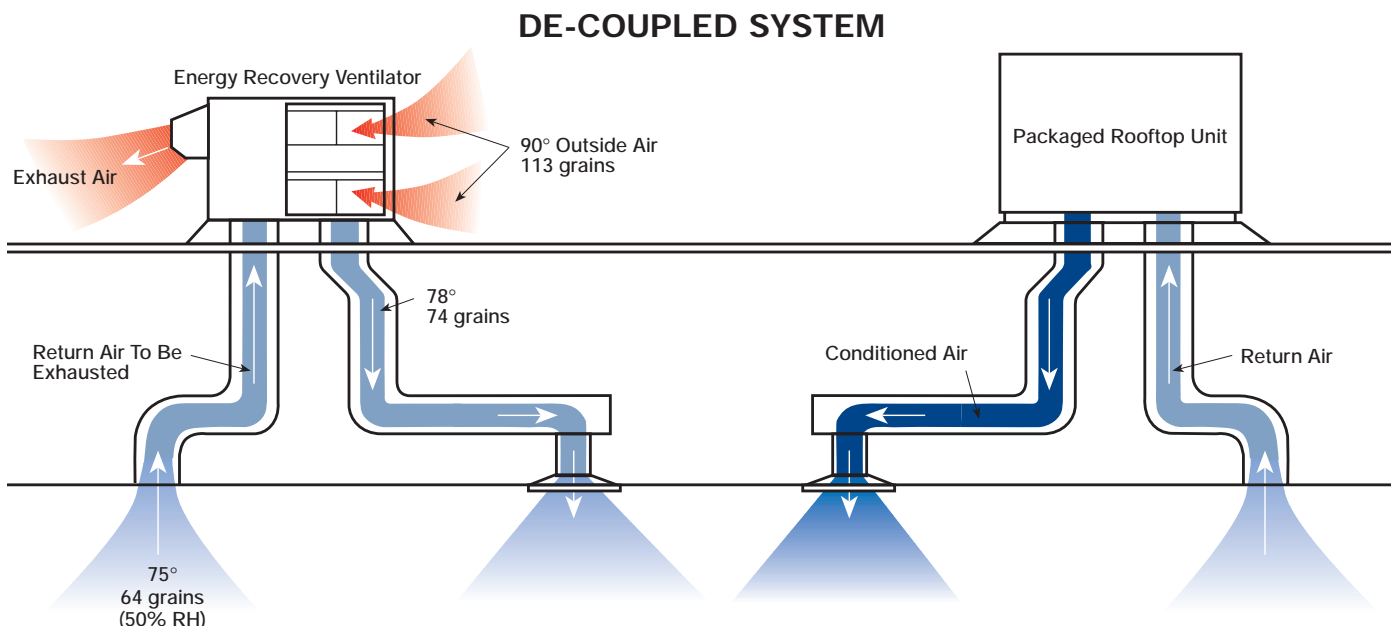

The airflow performance data shown applies to arrangement A and is licensed to bear the AMCA seal for Air Performance. Performance data for other arrangements may differ slightly. For specific performance for all arrangements, use Greenheck's Computer Aided Product Selection (CAPS) program.

Energy recovery wheel efficiency ratings are based on tests conducted in accordance with ASHRAE 84 and ARI 1060 standards. Published effectiveness values correspond to total energy transfer. Sensible only effectiveness will typically be slightly higher.

All models are available in A, B, C, & D arrangements. The energy transfer effectiveness values shown are for equal exhaust and supply airflows.

NOTES: 1. Performance tables show EXTERNAL static pressure capabilities.
2. BHP, Watt and Amp values shown are for one blower motor only.

Model ERV-251

ERV-251S (Standard Airflow) Supply & Exhaust Direct Drive

NOMINAL RPM	MAX. AMPS 115/230	MAX. WATTS (input)	EXTERNAL STATIC PRESSURE (in. wg)							
				0.250	0.375	0.500	0.625	0.750	1.000	1.250
950	3.0/1.5	300	CFM	563	536	498	450	378		
			EFF.	82%	83%	83%	84%	85%		
1150	5.3/2.7	530	CFM	700	680	658	634	597	513	
			EFF.	79%	80%	80%	81%	81%	83%	
1350	8.6/4.3	855	CFM	834	818	801	783	762	711	642
			EFF.	77%	77%	77%	78%	78%	79%	81%

ERV-251H (High Airflow) Supply & Exhaust Direct Drive

NOMINAL RPM	MAX. AMPS 115/230	MAX. WATTS (input)	EXTERNAL STATIC PRESSURE (in. wg)							
				0.250	0.375	0.500	0.625	0.750	1.000	1.250
1150	5.0/2.5	500	CFM	802	777	742	706	667		
			EFF.	73%	74%	74%	75%	76%		
1340	8.1/4.1	810	CFM	958	937	915	887	857	792	
			EFF.	71%	71%	72%	72%	73%	73%	
1520	11.5/5.8	1150	CFM	1089	1070	1051	1032	1008	954	895
			EFF.	68%	69%	69%	70%	70%	71%	72%

Speed (RPM) shown is nominal. Performance is based on actual speed of test. Performance ratings do not include the effects of appurtenances in the airstream. Performance at speeds of 950, 1150, and 1340 RPM are obtained with a speed control at 115 volts only. See note below.

Model ERV-361

ERV-361S (Standard Airflow) Supply & Exhaust Belt Drive

CFM	OV		EXTERNAL STATIC PRESSURE (in. wg)								WHEEL EFFICIENCY
			0.125	0.250	0.375	0.500	0.750	1.000	1.250	1.500	
1000	1552	RPM	777	863	941	1015	1147	1277	1397	1515	84%
		BHP	0.21	0.25	0.29	0.33	0.41	0.49	0.58	0.69	
1200	1863	RPM	899	974	1043	1109	1232	1343	1453	1557	83%
		BHP	0.34	0.39	0.43	0.48	0.58	0.68	0.78	0.87	
1400	2173	RPM	1023	1091	1153	1212	1324	1429	1527	1618	81%
		BHP	0.52	0.58	0.64	0.68	0.8	0.92	1.03	1.14	
1600	2484	RPM	1149	1212	1269	1323	1424	1520	1613	1701	80%
		BHP	0.75	0.82	0.89	0.95	1.07	1.20	1.34	1.47	

ERV-361H (High Airflow) Supply & Exhaust Belt Drive

CFM	OV		EXTERNAL STATIC PRESSURE (in. wg)								WHEEL EFFICIENCY
			0.125	0.250	0.375	0.500	0.750	1.000	1.250	1.500	
1600	2484	RPM	1006	1065	1122	1175	1275	1367	1457	1542	75%
		BHP	0.58	0.64	0.69	0.74	0.86	0.96	1.07	1.19	
1800	2795	RPM	1119	1172	1223	1272	1365	1452	1533	1613	74%
		BHP	0.82	0.88	0.93	0.99	1.12	1.25	1.36	1.49	
2000	3105	RPM	1232	1279	1326	1372	1458	1541	1618	1692	72%
		BHP	1.11	1.17	1.23	1.30	1.43	1.58	1.72	1.85	
2200	3416	RPM	1347	1389	1433	1474	1555	1633			71%
		BHP	1.46	1.53	1.60	1.67	1.81	1.97			

Gross supply air performance ratings for direct and belt drive models (airflow, pressure, and power) are at port 2 with port 1, port 3 and port 4 at 0.0 in. wg. Gross exhaust air performance ratings for direct and belt drive models (airflow, pressure, and power) are to port 3 with port 1, port 2 and port 4 at 0.0 in. wg. Power rating (BHP) does not include drive losses. Performance ratings do not include the effects of appurtenances in the airstream.

Model ERV-521

ERV-521S (Standard Airflow) Supply & Exhaust Belt Drive

CFM	OV		EXTERNAL STATIC PRESSURE (in. wg)								WHEEL EFFICIENCY
			0.125	0.250	0.375	0.500	0.750	1.000	1.250	1.500	
2250	1562	RPM	846	896	946	994	1084	1167	1249	1325	84%
		BHP	0.77	0.85	0.92	1.00	1.15	1.31	1.47	1.63	
2600	1805	RPM	964	1008	1050	1095	1176	1253	1325	1395	83%
		BHP	1.16	1.25	1.33	1.43	1.60	1.77	1.96	2.14	
2950	2048	RPM	1083	1121	1160	1197	1273	1344	1411	1476	81%
		BHP	1.67	1.77	1.87	1.96	2.17	2.36	2.56	2.77	
3300	2291	RPM	1202	1237	1272	1306	1374	1440	1504		80%
		BHP	2.31	2.41	2.53	2.64	2.86	3.09	3.31		

Model ERV-581

ERV-521H (High Airflow) Supply & Exhaust Belt Drive

CFM	OV		EXTERNAL STATIC PRESSURE (in. wg)								WHEEL EFFICIENCY
			0.125	0.250	0.375	0.500	0.750	1.000	1.250	1.500	
3100	2152	RPM	980	1017	1054	1089	1159	1226	1290	1355	76%
		BHP	1.57	1.65	1.73	1.82	1.99	2.18	2.36	2.54	
3500	2430	RPM	1097	1130	1163	1195	1258	1319	1379	1435	74%
		BHP	2.23	2.33	2.42	2.51	2.71	2.90	3.11	3.31	
3900	2708	RPM	1216	1245	1275	1304	1361	1417	1472	1525	73%
		BHP	3.06	3.17	3.27	3.38	3.58	3.80	4.03	4.26	
4300	2986	RPM	1334	1361	1388	1415	1467	1519	1569		72%
		BHP	4.08	4.20	4.31	4.43	4.65	4.89	5.13		

ERV-581H (High Airflow) Supply & Exhaust Belt Drive

CFM	OV		EXTERNAL STATIC PRESSURE (in. wg)								WHEEL EFFICIENCY
			0.125	0.250	0.375	0.500	0.750	1.000	1.250	1.500	
4300	2036	RPM	637	687	733	772	850	923	988	1055	76%
		BHP	1.20	1.35	1.49	1.61	1.88	2.16	2.42	2.73	
4800	2273	RPM	700	745	788	827	895	967	1031	1090	74%
		BHP	1.64	1.79	1.96	2.10	2.38	2.70	3.01	3.30	
5300	2510	RPM	763	804	845	883	949	1012	1075	1133	72%
		BHP	2.16	2.34	2.52	2.69	3.00	3.33	3.68	4.02	
5800	2747	RPM	826	866	903	939	1004	1061	1120	1177	71%
		BHP	2.79	2.99	3.18	3.38	3.74	4.07	4.44	4.83	

Model ERV-522

ERV-522S (Standard Airflow) Supply & Exhaust Belt Drive

CFM	OV		EXTERNAL STATIC PRESSURE (in. wg)								WHEEL EFFICIENCY
			0.125	0.250	0.375	0.500	0.750	1.000	1.250	1.500	
5000	2500	RPM	754	793	831	869	943	1010	1071	1133	83%
		BHP	2.22	2.39	2.57	2.76	3.15	3.54	3.89	4.30	
5500	2750	RPM	821	859	891	927	994	1061	1121	1176	82%
		BHP	2.89	3.09	3.29	3.50	3.89	4.36	4.77	5.16	
6000	3000	RPM	888	925	956	986	1050	1112	1171	1225	81%
		BHP	3.71	3.92	4.15	4.37	4.81	5.28	5.77	6.22	
6500	3250	RPM	956	991	1021	1048	1108	1164	1222	1275	80%
		BHP	4.67	4.9	5.15	5.39	5.88	6.33	6.89	7.41	

ERV-522H (High Airflow) Supply & Exhaust Belt Drive

CFM	OV		EXTERNAL STATIC PRESSURE (in. wg)								WHEEL EFFICIENCY
			0.125	0.250	0.375	0.500	0.750	1.000	1.250	1.500	
6000	1920	RPM	535	581	619	660	731	797	857	913	76%
		BHP	1.57	1.79	1.96	2.16	2.55	2.94	3.33	3.72	
7000	2240	RPM	608	651	687	720	788	849	905	959	75%
		BHP	2.39	2.67	2.89	3.10	3.56	4.01	4.46	4.93	
8000	2560	RPM	684	722	757	787	847	906	958	1008	73%
		BHP	3.49	3.79	4.09	4.34	4.84	5.36	5.88	6.34	
9000	2880	RPM	763	794	827	857	910	964	1016	1063	71%
		BHP	4.90	5.20	5.57	5.89	6.42	7.01	7.60	8.18	

Gross supply air performance ratings (airflow, pressure, and power) are at port 2 with port 1, port 3 and port 4 at 0.0 in. wg Gross exhaust air performance ratings (airflow, pressure, and power) are to port 3 with port 1, port 2 and port 4 at 0.0 in. wg. Power rating (BHP) does not include drive losses. Performance ratings do not include the effects of appurtenances in the airstream.

DAMPERS - INTERNALLY MOUNTED

A wide variety of dampers are available in either gravity or motorized operation. Dampers are internally mounted at the supply and exhaust inlet. Motorized dampers are factory wired to single point power connection.

Motorized dampers are available in standard (WD-220), low leakage (VCD-23) and insulated low leakage (VCD-34) construction.

DUCT MOUNTED DAMPERS

For exhaust or supply, model WD-330 gravity and motorized dampers are available for duct mount installations. Damper will ship loose with ERV.

SUPPLY AND EXHAUST AIR FILTER

Standard size 2 inch pleated, medium efficiency filters and filter racks are available for supply and/or exhaust air streams.

Model	Filter Size	Quantity
ERV-251	16 x 25	1
ERV-361	16 x 20	2
ERV-521	16 x 25	3
ERV-581	16 x 20	6
ERV-522	16 x 25	7

PAINTED EXTERIORS

Greenheck's Permatecor coating is available for a durable, long lasting finish. Decorative paints are available in a variety of colors to match existing building fixtures. Consult your Greenheck representative for paint selections.

ROOF CURBS

Prefabricated roof curbs are available to ensure compatibility between ventilator, curb and roof opening. Standard construction is galvanized steel and includes fiberglass insulation. Curbs are supplied with duct adapters. Model ERV-522 curbs are shipped knock down without insulation.

Curb Outside Dimensions

Model	L x W
ERV-251	30 ¹ / ₂ x 42 ¹ / ₂
ERV-361	58 ¹ / ₂ x 47 ¹ / ₂
ERV-521	63 ¹ / ₂ x 63 ¹ / ₂
ERV-581	71 ³ / ₄ x 66
ERV-522	120 ¹ / ₂ x 80 ¹ / ₂

DOUBLE WALL CONSTRUCTION

Supply and exhaust side are internally lined with 20 gauge galvanized steel.

WEATHER HOODS

All exterior arrangements (B, C & D) are supplied with a louvered intake hood with 2 inch aluminum mesh filters and exhaust hood with integral backdraft damper as standard.

DIRTY FILTER SENSORS

Pressure taps sense excessive pressure drop across the filter and sends a signal to a dirty filter indicator light. Light and control box are available from the factory or supplied by others

ROTATION SENSORS

Sensor monitors wheel rotation. Signal may be sent to remote indicator light. Light and control box are available from the factory or supplied by others

ECONOMIZER OUTDOOR AIR SENSORS

Outdoor air sensors interact with a factory mounted thermostat that is field adjustable. The sensor stops the energy recovery wheel from rotating during "economizer or free cooling" conditions.

ENTHALPY SENSOR - High Outdoor Humidity

Sensor is installed in the inlet air compartment and monitors outdoor temperature and humidity. A remote mounted switch is required to bypass sensor in winter operation. Switch and control box are available from the factory or supplied by others.

TEMPERATURE SENSOR - Low Outdoor Humidity

Sensor is installed in the inlet air compartment and monitors outdoor temperature. A remote mounted switch is required to bypass sensor in winter operation. Switch and control box are available from the factory or supplied by others.

ECONOMIZER AUTOMATIC OVERRIDE SENSOR

A temperature sensor is installed to override/switch the unit into winter operation automatically. The temperature switch replaces the remote panel switch to bypass sensor.

SENSIBLE ONLY WHEEL

The energy recovery wheel is available without a desiccant coating for sensible only heat transfer.

SPEED CONTROL

Speed control for system balancing is available for model ERV-251. All other models are available with two speed motors. Variable frequency drives for motors are available in some models, consult Greenheck representative for details.

HINGED ACCESS DOORS

Panel side doors are a standard feature on all units. Hinged access doors are available on models ERV-361, ERV-521, ERV-581 and ERV-522. Access doors are removable hinge type with lift and turn latches for access to internal components.

FROST CONTROL OPTIONS

The frost threshold is the outdoor temperature at which frost will begin to form on the ERV wheel. For Greenheck energy recovery ventilators, the frost threshold is typically below 5°F. Frost threshold is dependent on indoor temperature and humidity. The table at right shows how the frost threshold temperatures vary depending on indoor conditions.

FROST THRESHOLD TEMPERATURE

Indoor RH at 70° F	Frost Threshold Temperature
20%	-10°F
30%	-5°F
40%	0°F

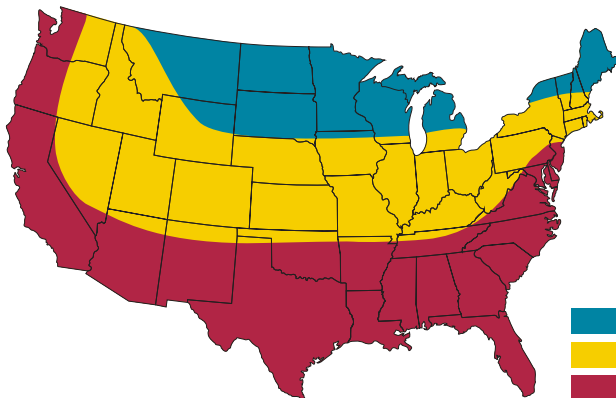

- Pre Heat Frost Control Recommended
- Timed Exhaust Frost Control Recommended
- No Frost Control Needed

Because Greenheck Energy Recovery Ventilators have a low frost threshold, frost control options are not necessary in many climates. Where outdoor temperatures may drop below the frost threshold during the ERV operational hours, two frost control options are available. The map at left indicates the frost control options, if any, that are appropriate based on climactic conditions during typical 16 hour per day operation.

TIMED EXHAUST FROST CONTROL

Timed exhaust frost control turns the supply blower power off and on per field adjustable timer settings when outdoor temperature falls below the frost threshold. The temperature set points are field adjustable with a factory supplied thermostat.

Timed Exhaust is appropriate for climates with limited HVAC system operation when outdoor temperatures are below 0° F.

PREHEAT FROST CONTROL

Preheat Frost Control enables continuous operation when outdoor temperatures are below the frost threshold. An electric heater warms outdoor air above the frost threshold before it enters the ERV wheel. The

heater is supplied with a set point that is field adjustable between 0 F and 15 F. This option is available on all models.

To size the heater properly, use the following equation:

$$\text{Required kW} = 1.08 \times \text{CFM} \times \Delta T \div 3414;$$

where ΔT is the difference between the winter design and frost threshold temperatures. Refer to page 14 for standard electric heaters. Consult factory for other electric kW's.

Heater sizes and minimum circuit amp calculations are shown in the table on page 14. Preheat is available in single phase power for ERV-251 only. All other unit preheaters require three phase power supply.

MODELS ERV-251, ERV-361 ERV-521 AND ERV-581

Model	Exterior Dimensions					Duct Dimensions						Weight (lbs)
	A	B	C	D	E	F	G	K	L	O	P	
ERV-251	46	34	27	16	8	10	16	6 $\frac{3}{4}$	7	10	16	250
ERV-361	62	51	34	15	15	18	18	8 $\frac{3}{8}$	11 $\frac{1}{2}$	19	18	750
ERV-521	67	67	44	18	15	24	24	10 $\frac{3}{4}$	13 $\frac{1}{2}$	26	26	1200
ERV-581	75	70	67	16	22	22	27	16	18 $\frac{3}{4}$	28	48	2500

All dimensions are in inches.

Arrangement A

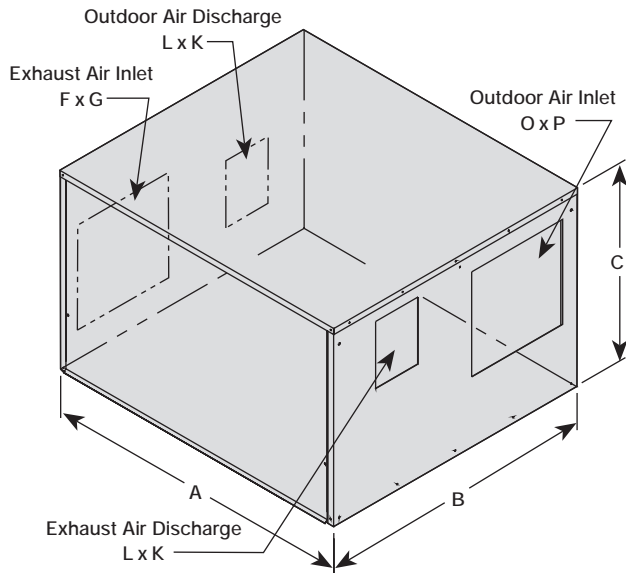

Arrangement B

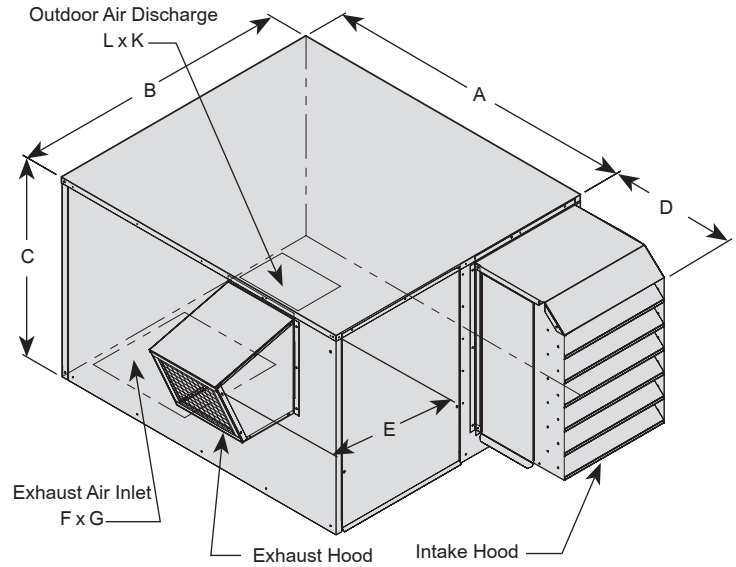

Arrangement C

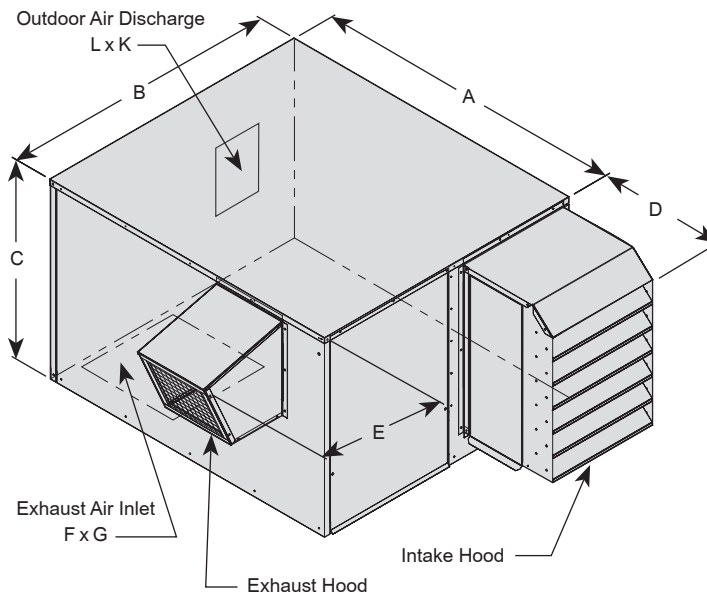

Arrangement D

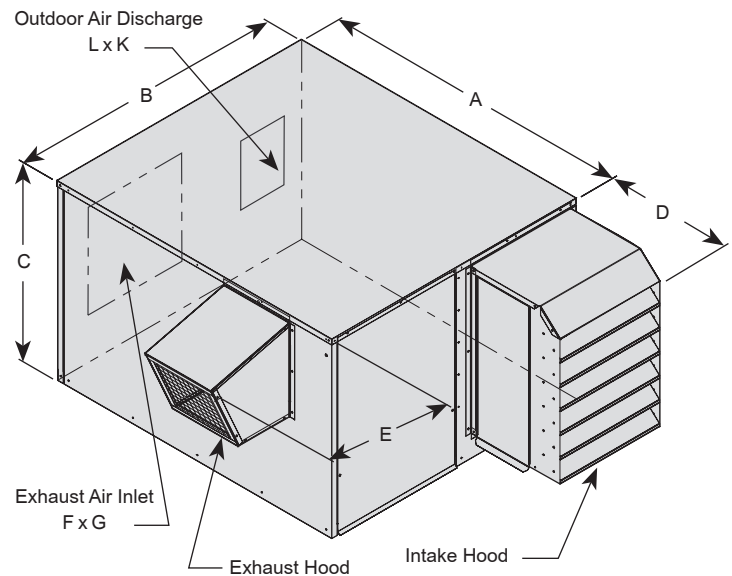

Service Clearance

Installation must allow clearance for access to the energy recovery wheel on the supply side. Minimum clearances are shown in the table at right. Page 4 illustrates the side panel that enables wheel access.

Model	Supply Side	Exhaust Side
ERV-251	32	30
ERV-361	44	30
ERV-521	60	40
ERV-581	65	40

MODEL ERV-522

Model	K	L	Weight
ERV-522S	16	18 $\frac{3}{8}$	3000
ERV-522H	19	22	3000

Arrangement A

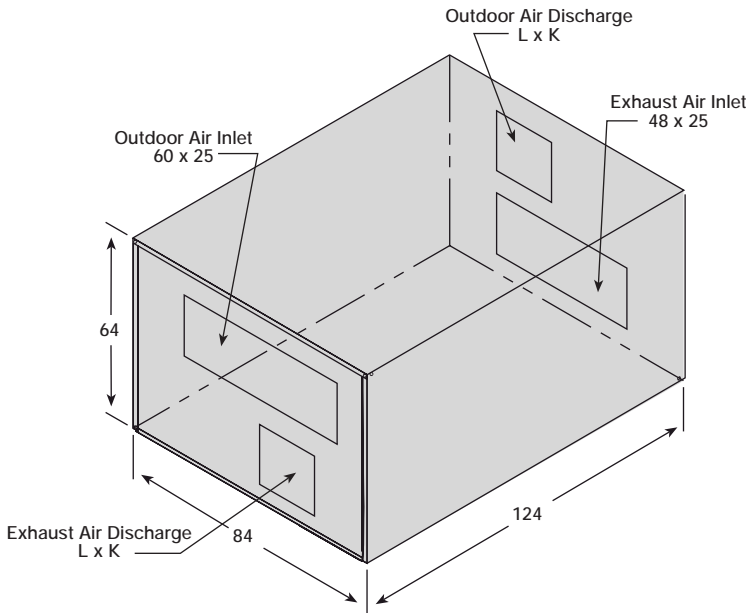

Arrangement B

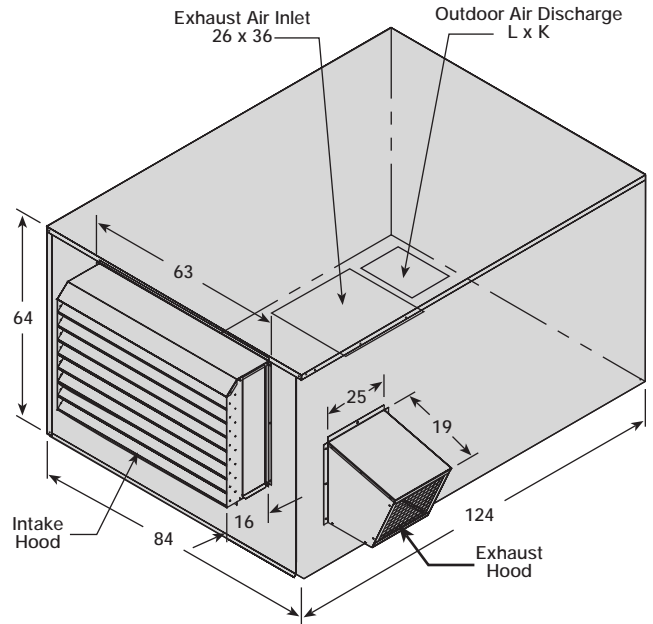

Arrangement C

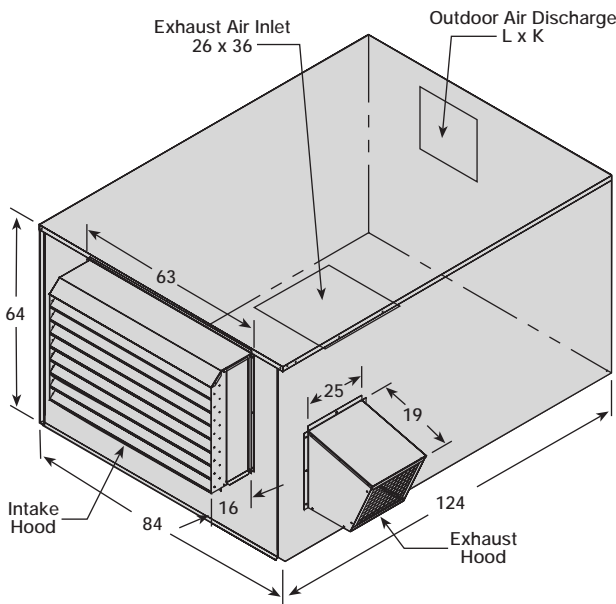

Arrangement D

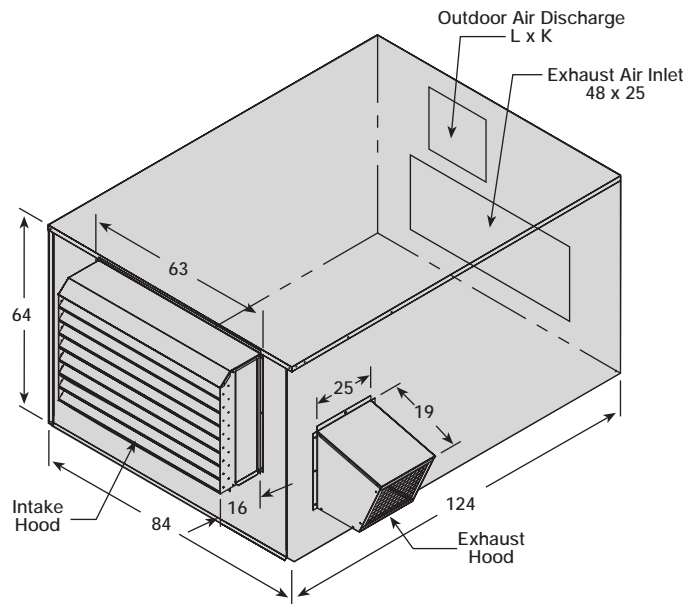

Service Clearance

The installation must allow clearance for access to the energy recovery wheels and servicing. For model ERV-522, allow a clearance of 38 inches on all sides.

Model ERV-522 energy wheels are mounted in an upright position, side by side. For servicing, the energy wheels slide out of the ventilator at opposite corners.

MOTOR SPECIFICATIONS

Blower motor information must be specified to select unit. The horsepower, voltage, phase and enclosure availability is presented in the table on the right. If exhaust and supply blower horsepower are different, consult the CAPS program.

Model	Open			TE		2 Speed Open	
	115/1	230/1	230/460/3	230/1	230/460/3	230/1	230/460/3
ERV-251S*	1/4	1/4	-	-	-	-	-
ERV-251H*	3/4	3/4	-	-	-	-	-
ERV-361*	-	1/4 - 2	1/4 - 2	1/4 - 2	1/4 - 2	1/2 - 1	1/2 - 1 1/2
ERV-521*	-	1/2 - 3	1/2 - 5	1/2 - 1 1/2	1/2 - 5	1/2 - 1	1/2 - 3
ERV-581*	-	-	1 - 5	-	1 - 5	-	1 - 3
ERV-522*	-	1 1/2 - 3	1 1/2 - 15	1 1/2	1 - 15	-	1 - 7 1/2

UL Listing is available on most open drip proof motors. * Energy wheel drive motor is only available with open drip proof motors.

MINIMUM CIRCUIT AMPS (MCA) CALCULATIONS FOR ERV UNITS

Wheel Drive and 24v Internal Control Amp Single or Three Phase ERV Units

Model	Wheel Drive Amps			24v Control Amps
	115v	208/230	460	
ERV-251S/H	0.6	0.6	na	0.5
ERV-361 S/H	na	1.2	0.6	1
ERV-521 S/H	na	2.8	1.4	1
ERV-581 H	na	1.6	0.8	1
ERV-522 S/H	na	5.6	2.8	1

Standard Electric Preheat kW

Model	115v/1 ph	208v/1ph	230v/1 ph	208v/3 ph	230v/3 ph	460v/3 ph
ERV-251S/H	2.5	2.1, 4.1	2.5, 5	na	na	na
ERV-361 S/H	na	na	na	4.1, 8.2, 12.3	5, 10, 15	5, 10, 15
ERV-521 S/H	na	na	na	8.2, 12.3, 15.5	10, 15, 19	10, 15, 20, 25, 30
ERV-581 H	na	na	na	12.3, 15.5	15, 19	15, 20, 25, 30, 38
ERV-522 S/H	na	na	na	15.5	19	20, 25, 30, 45

MCA EXAMPLE CALCULATION

Greenheck ERV Selected: ERV-361S-B, 2 hp supply motor, 1 1/2 hp exhaust motor, 15kW preheater operating at 460v/3 phase.

- Step 1: Consult NEC table (not shown) for 2 hp supply motor
amps = 3.4 A.
- Step 2: Consult NEC table (not shown) for 1 1/2 hp exhaust motor
amps = 2.6 A.
- Step 3: Calculate 15kW preheater amp draw = $15,000W / [460 * \sqrt{3}] = 18.8$ A. If no preheater is used skip step 3.
- Step 4: Wheel drive amps for ERV-361 from table above = 0.6 A.
- Step 5: 24v Control Amps for ERV-361 from table above = 1.0 A.
- Step 6: MCA = Amperage total from steps 1 thru 5 X 1.25.
MCA = (3.4 + 2.6 + 18.8 + 0.6 + 1.0) 1.25 = 33 A.

Note: Calculations are approximate, use the CAPS Selection Program for exact MCA calculations.

Filter Pressure Drop

Model	CFM	Intake Hood w/ 2 in. alum filters	Pleated 2 in. filters
251	500	0.09	0.09
	750	0.17	0.14
	1000	0.32	0.19
361	1000	0.09	0.10
	1600	0.22	0.18
	2200	0.45	0.28
521	2500	0.13	0.14
	3500	0.25	0.22
	4500	0.45	0.32
581	4500	0.17	0.15
	5000	0.26	0.18
	5500	0.30	0.24
522	6000	0.15	0.14
	8000	0.27	0.21
	9000	0.40	0.25

General: Energy Recovery Ventilator shall be as manufactured by "Greenheck" or approved equal, provided all specifications are met. Greenheck Model ERV equipment is used as the basis of design. Units shall be UL listed and bear the UL label. Energy transfer ratings shall be in accordance with ASHRAE Standard 84. Ventilators shall bear the AMCA Certified Rating Seals for air performance. Performance to be as scheduled on plans. Outdoor air shall not mix with exhaust air in a common plenum. Exhaust discharge and outside air intake shall not be located on the same side on roof top units.

Unit Casing and Frames: Unit shall be of internal frame type construction of G90 galvanized steel. All panels exposed to the weather shall be a minimum of 20 gauge galvanized steel. Where top panels are joined there shall be a standing seam to insure positive weather protection. All exterior metal-to-metal seams shall be sealed with closed cell neoprene gasketing, requiring no caulking at job site. Unit base to be designed for curb mounting. Unit base shall over hang the curb. Curb is to be recessed under the unit for a positive seal against water run-off. All components shall be easily accessible through large removable access panels for both exhaust and supply compartments. Energy recovery wheel shall be mounted in a slide-out track for ease of inspection, removal and cleaning. Access to be provided in each individual section where blowers, filters and motorized damper are required.

Weather Hoods: Weather hoods shall be of the same finish as the unit. Supply weather hood shall be louvered to stop wind driven rain and incorporate a moisture eliminator. Moisture eliminator shall be of aluminum, consisting of corrugated mesh to eliminate water penetration into unit. Exhaust weather hood shall include an automatic backdraft damper and bird screen.

Energy Recovery Wheel: Wheel shall be of the enthalpy type for both sensible and latent heat recovery, and be designed to insure laminar flow. Desiccant shall be silica gel for maximum latent energy transfer. Wheel shall be constructed of light weight polymer media to minimize shaft and bearing loads. Polymer media shall be mounted in a stainless steel rotor for corrosion resistance.

Wheel design shall consist of removable segments (for wheels greater than 26 in. diameter) for ease of service and/or cleaning. Segments shall be removable without the use of tools. Wheel shall be on a slide out track. Silica gel desiccant shall be permanently bonded to wheel media to retain latent heat recovery after cleaning. Wheels with sprayed on desiccant coatings are not acceptable. Wheels with desiccant applied after wheel formation are not acceptable.

Insulation: Unit casing to be insulated with 1in. - 3# rigid board fiberglass with fire-resistant Foil-Scrim-Kraft facing. Insulation shall be in accordance with NFPA 90A and tested to meet UL 181 erosion requirements and to be secured to unit with water proof adhesive and permanent mechanical fasteners.

Access Doors: All components shall be easily accessible through removable hinged access doors for both exhaust and supply compartments. Energy recovery wheel shall be mounted in a slide out track for ease of inspection, removal and cleaning. Access to be provided in each section where blowers, filters and motorized damper are required.

Fan Sections: Centrifugal fans to be double width, double inlet, single fan forward curved type. All blower wheels shall be statically and dynamically balanced. Motors shall be permanently lubricated, heavy duty type, matched to the fan load and furnished at the specified voltage, phase and enclosure. Ground and polished steel fan shafts shall be mounted in permanently lubricated, sealed ball bearing pillow blocks. Bearings shall be selected for a minimum (L10) life in excess of 100,000 hours at maximum cataloged operating speeds. Blowers shall be quiet running, forward curved type and enable independent balancing of exhaust and supply airflows by providing separate motors for exhaust and supply blowers with adjustable sheaves. Neoprene isolation standard on motor/blower assembly.

Motors and Drives: Motors shall be minimum horse power scheduled 1800 RPM-single speed ball bearing, rigid base, T-frame, ODP. Motors shall operate on 480 volts, three phase, 60 Hz and be factory mounted to an adjustable motor plate having two heavy duty adjusting bolts for alignment and belt tension. Drives shall be sized for a minimum of 150% of driven horsepower. Pulleys shall be fully machined cast, 15 horsepower and less shall be supplied with an adjustable drive.

Filters: Supply and exhaust air filters shall be 2 inch thick pleated, 30% efficient and tested to meet UL Class 2. Filter racks shall be die formed galvanized steel.

Electrical: All internal electrical components shall be prewired for single point power connection. All electrical components shall be UL listed, approved or classified where applicable and wired in compliance with the National Electrical Code. Weather proof disconnect switch and motor starters shall be supplied as standard components. Control box shall include motor starters, control circuit fusing, control transformer for 24 VAC circuit and door interlocking safety disconnect. Motor starters shall consist of a contactor and Class 20 adjustable overload protection and shall be provided for all blower motors in the unit.

ADDITIONAL ENERGY RECOVERY PRODUCTS

Model ERT

The Model ERT combines the benefits of energy recovery with supplemental heating and cooling. The unit is designed to process 100% outdoor air to desired supply conditions.

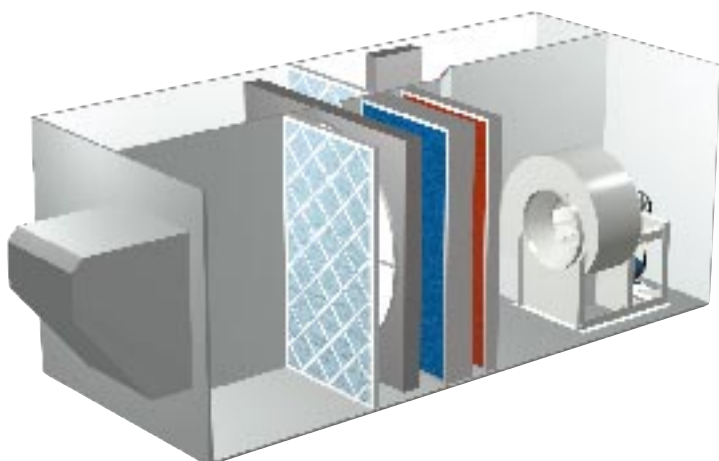

Model ERM

The model ERM energy recovery modules offer the advantages of Greenheck's energy recovery wheel for use in build-up ventilation systems. Modules are ideal for new construction or retrofit applications where a model ERV does not meet space requirements.

Mini Vent-450

The Mini Vent-450 energy recovery ventilator is designed for applications requiring 300-500 cfm. The unit is designed for floor mount, wall mount or hanging from the ceiling.



Warranty

Greenheck warrants this equipment to be free from defects in material and workmanship for a period of one year from the purchase date. The energy recovery wheel is warranted to be free from defects in material and workmanship for a period of five years from the purchase date. Any units or parts which prove defective during the warranty period will be replaced at our option when returned to our factory, transportation prepaid.

Motors are warranted by the motor manufacturer for a period of one year. Should motors furnished by Greenheck prove defective during this period, they should be returned to the nearest authorized motor service station. Greenheck will not be responsible for any removal or installation costs.

Due to continuing research, Greenheck reserves the right to change specifications without notice.



Number one in air movement and control.



Centrifugal and Vane Axial Fans



Fans and Ventilators



Energy Recovery Ventilators & Make-Up Air Units



Kitchen Ventilation Systems



Dampers and Louvers

Visit the Greenheck website for the most current information available
www.greenheck.com

Greenheck ¥ P.O. Box 410 Schofield, WI 54476-0410 ¥ Phone (715) 359-6171 ¥ Fax (715) 355-2399 ¥ www.greenheck.com