

MODEL ERCH

ENERGY RECOVERY VENTILATOR *with* *Cooling & Heating*

- Commercial
- Institutional

Applications up to:

- 10,000 cfm
- 1.5 in. wg external static pressure



GREENHECK

The Solution Company.

June 2001

Model ERCH

Energy Recovery Ventilator With **Cooling & Heating**

The model ERCH combines the benefits of the total energy wheel with supplemental heating and cooling. The result is a product that is specifically designed to process 100% outdoor air to desired supply conditions. Four housing sizes provide air flow capacities from 1,000 cfm to 10,000 cfm with external static pressures up to 1.5 in. wg (for requirements above this performance, refer to Model ERT).

Product operation is simple:

- Fresh outdoor air is pre-conditioned by the total enthalpy wheel, recovering up to 80% of the energy from the exhaust air.
- The coil section further conditions the outdoor air to desired conditions (typically near room conditions).

Single Point

Wiring is standard. A disconnect switch and low voltage terminal strip are provided.

Access Doors

provide easy access to blowers, energy wheel, filters, and coil section for inspection and routine service.

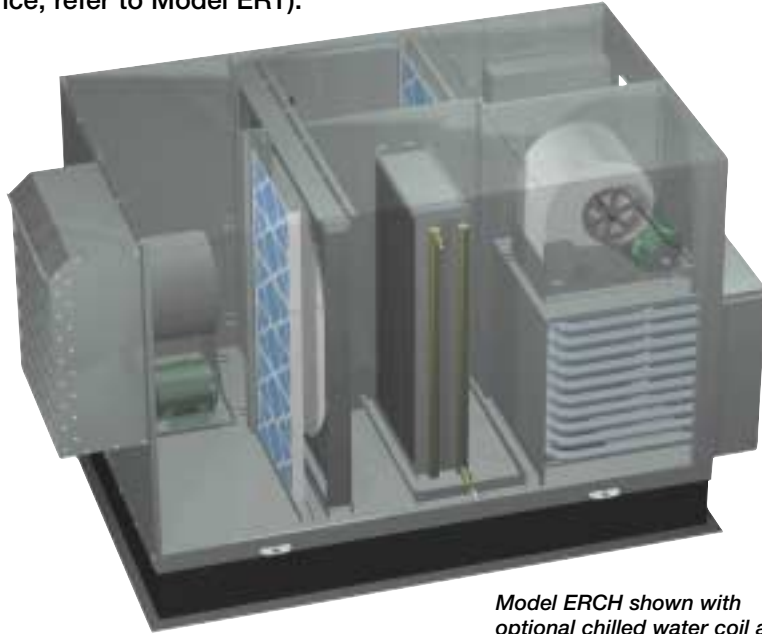

Model ERCH shown with optional chilled water coil and indirect gas heater.

The Coil Section

provides supplemental cooling or heating of the outdoor air after pre-conditioning by the energy wheel. Tempering options include chilled water, direct expansion, hot water, electric heat, and indirect gas.



Forward Curved Blowers are mounted on isolation bases with neoprene vibration isolators standard.

Double Wall Housing is standard. The housing is constructed of heavy gauge steel with insulation. The supply and exhaust side are internally lined with galvanized steel.

A Control Box is furnished with motor starters for the supply blower, exhaust blower and wheel motors. Also included is a 24 volt control circuit.



Benefits

Healthy Buildings:

Ventilate buildings adequately without losing control of the indoor humidity levels. The ERCH is capable of dehumidifying humid summer air to room design conditions. Also, it helps prevent overly dry winter air that can contribute to respiratory irritation.

Load Reduction:

The energy wheel will reduce the air conditioning load by 3 to 4 tons for every 1,000 cfm of outdoor air for many climates.

ASHRAE 62 Compliance:

By assuring that minimum outdoor air volumes are

delivered to the room spaces, compliance with the ASHRAE 62 Standard is clearly demonstrated.

System Design Simplicity:

The ERCH is designed specifically to perform the function of providing outdoor air to the space at desired conditions. This effectively de-couples the outdoor air load from the building load, enabling the traditional VAV system to perform as it was intended in response to building loads.

Low Maintenance:

Servicing is minimal. All components have a well established history of reliable operation.

To expand the cooling and heating capabilities of the energy recovery wheel, a variety of tempering options are available. The coil section of the ERCH accommodates a cooling coil, a heating coil, or both.

A description of the cooling and heating processes along with a psychrometric illustration is shown below. Cooling and heating coil options are also listed.

Consult your Greenheck representative for coil selections or for tempering options not listed.

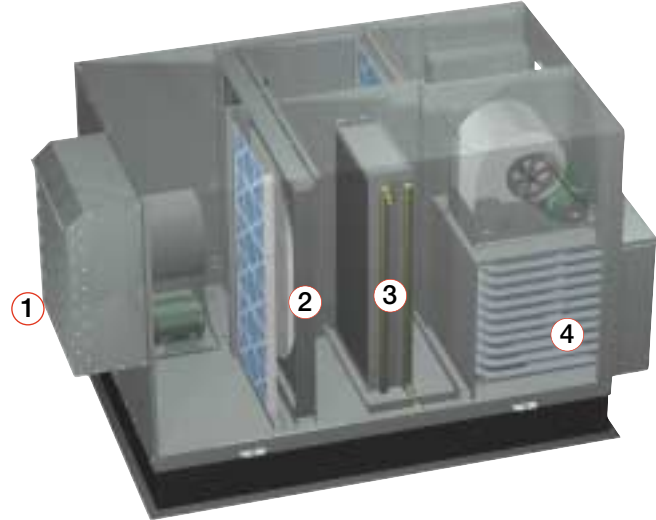

Cooling

Supplemental cooling is recommended when the air conditions leaving the energy recovery wheel have not been cooled or dehumidified to the desired leaving conditions.

Cooling Options

- Chilled Water
- Direct Expansion

Re-heat Options

- Electric
- Hot Water
- Indirect Gas

1. Outdoor air enters ERCH unit.
2. The energy recovery wheel cools and dehumidifies outdoor air using energy from the exhaust air stream. Load is reduced by 3 to 4 tons per 1,000 cfm for many climates.
3. The cooling coil provides supplemental cooling to further treat the outdoor air to desired supply conditions.
4. Optional reheat available to provide space neutral air.

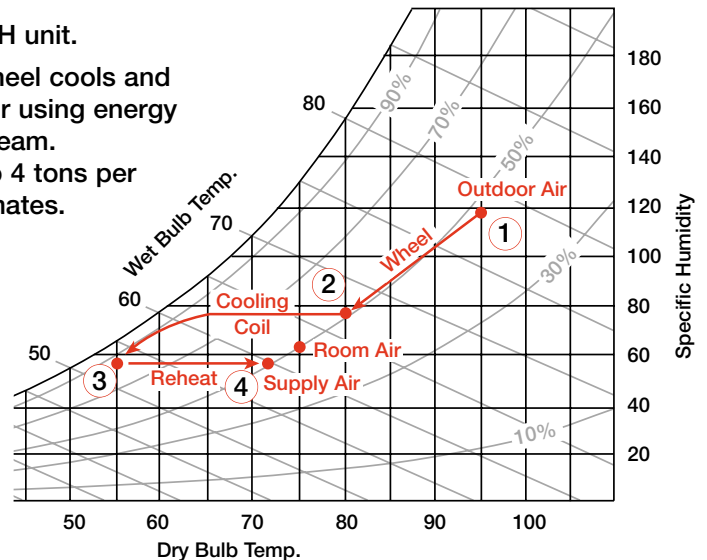

Heating

Supplemental heating is recommended when the air conditions leaving the energy recovery wheel have not been heated to the desired leaving conditions.

Heating Options

- Electric
- Hot Water
- Indirect Gas

Indirect gas units are outdoor only.

1. Outdoor air enters ERCH unit.
2. The energy recovery wheel heats and humidifies winter outdoor air using energy from the exhaust air stream. Heating bills are significantly reduced and overly dry indoor conditions are eliminated.
3. The heating coil or furnace provides supplemental heating to further treat the outdoor air to desired supply conditions.

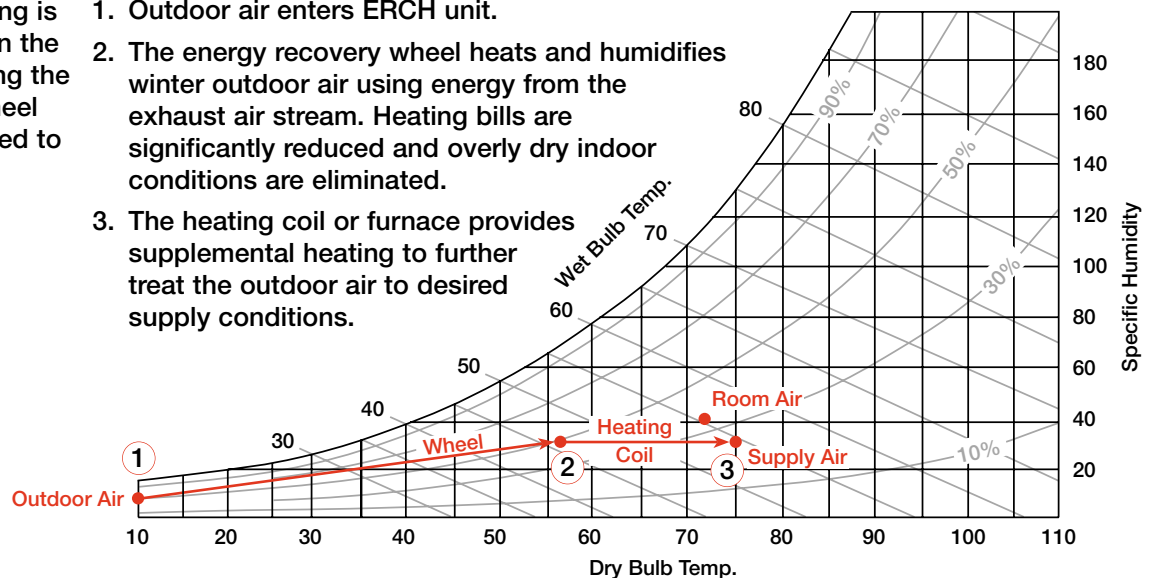

ERCH-20M

Belt Drive

CFM	OV		EXTERNAL STATIC PRESSURE in inches of WG							WHEEL EFFICIENCY	
			0.50	0.75	1.00	1.50	2.00	2.50	3.00		3.50
1000	1142	RPM	1160	1338	1498						84
		BHP	0.32	0.42	0.53						
1300	1485	RPM	1306	1452	1594	1857					82
		BHP	0.52	0.64	0.77	1.05					
1600	1828	RPM	1467	1604	1722	1955	2174	2374			80
		BHP	0.83	0.97	1.12	1.43	1.77	2.11			

ERCH-20H

Belt Drive

CFM	OV		EXTERNAL STATIC PRESSURE in inches of WG							WHEEL EFFICIENCY	
			0.50	0.75	1.00	1.50	2.00	2.50	3.00		3.50
1600	1828	RPM	1221	1350	1475	1698	1893				75
		BHP	0.59	0.70	0.82	1.06	1.31				
1900	2171	RPM	1352	1470	1579	1786	1976	2148	2314		73
		BHP	0.88	1.02	1.15	1.43	1.72	2.01	2.32		
2200	2514	RPM	1491	1600	1700	1887	2065	2230	2385		71
		BHP	1.26	1.42	1.57	1.88	2.21	2.54	2.88		

ERCH-45L

Belt Drive

CFM	OV		EXTERNAL STATIC PRESSURE in inches of WG							WHEEL EFFICIENCY	
			0.50	0.75	1.00	1.50	2.00	2.50	3.00		3.50
2200	2109	RPM	756	830	897	1020	1130	1257	1371	1477	84
		BHP	0.67	0.79	0.90	1.14	1.39	1.78	2.20	2.62	
2700	2588	RPM	867	927	988	1100	1203	1295	1385	1490	82
		BHP	1.13	1.24	1.38	1.66	1.96	2.25	2.56	3.04	
3200	3068	RPM	982	1038	1089	1190	1283	1374	1456	1533	80
		BHP	1.74	1.91	2.04	2.36	2.69	3.05	3.40	3.73	

ERCH-45H

Belt Drive

CFM	OV		EXTERNAL STATIC PRESSURE in inches of WG							WHEEL EFFICIENCY	
			0.50	0.75	1.00	1.50	2.00	2.50	3.00		3.50
3200	2184	RPM	900	989	1071	1220	1360				75
		BHP	1.17	1.34	1.53	1.92	2.35				
3800	2593	RPM	1004	1083	1157	1297	1422	1542	1654		73
		BHP	1.79	1.99	2.20	2.64	3.11	3.61	4.12		
4400	3003	RPM	1114	1185	1252	1380	1499	1609	1713	1815	71
		BHP	2.60	2.85	3.08	3.57	4.09	4.64	5.18	5.78	

ERCH-55H

Belt Drive

CFM	OV		EXTERNAL STATIC PRESSURE in inches of WG							WHEEL EFFICIENCY	
			0.50	0.75	1.00	1.50	2.00	2.50	3.00		3.50
4200	1989	RPM	751	829	904	1039	1160				75
		BHP	1.49	1.74	2.01	2.58	3.17				
5100	2415	RPM	844	915	981	1103	1215	1321	1418		73
		BHP	2.37	2.68	2.99	3.63	4.31	5.04	5.75		
6000	2842	RPM	942	1008	1068	1179	1283	1377	1473	1561	71
		BHP	3.57	3.95	4.32	5.03	5.80	6.54	7.42	8.27	

ERCH-90H

Belt Drive

CFM	OV		EXTERNAL STATIC PRESSURE in inches of WG							WHEEL EFFICIENCY	
			0.50	0.75	1.00	1.50	2.00	2.50	3.00		3.50
6000	2066	RPM	643	708	768	878	981	1077			77
		BHP	2.15	2.52	2.89	3.63	4.47	5.32			
8000	2755	RPM	773	828	879	974	1063	1144	1224	1300	73
		BHP	4.29	4.82	5.31	6.30	7.31	8.29	9.37	10.47	
10,000	3444	RPM	912	960	1005	1089	1168	1240	1312	1379	70
		BHP	7.61	8.29	8.98	10.22	11.48	12.67	13.97	15.22	

The air performance data on page 4 accounts for the pressure drop across the energy recovery wheel and the internal housing losses, but does *not* include pressure drop for filters or tempering options. Add filter and/or tempering option pressure drop (from tables below) to external static pressure to determine correct rpm and horsepower.

Filter Pressure Drop (30% eff.)

Model	CFM	Pressure Drop (in. wg)
ERCH-20	1000	0.04
	2200	0.22
ERCH-45	2200	0.06
	4400	0.24
ERCH-55	4200	0.09
	6000	0.18
ERCH-90	6000	0.10
	10,000	0.27

Tempering Options Pressure Drop

Model	CFM	Cooling Coil (in. wg)	Heating Coil (in. wg)	Indirect Gas (in. wg)
ERCH-20	1000	0.17	0.02	0.03
	2200	0.62	0.08	0.13
ERCH-45	2200	0.31	0.04	0.09
	4400	0.66	0.08	0.34
ERCH-55	4200	0.38	0.04	0.10
	6000	0.64	0.08	0.26
ERCH-90	6000	0.28	0.03	0.24
	10,000	0.66	0.08	0.55

NOTE: Coil data assumes 6 row cooling coils and 1 row heating coils.

Intake & Discharge Options

Model ERCH offers installation flexibility with a wide selection of intake and discharge locations. This accommodates various duct connection requirements for either rooftop or equipment room installations. The table below indicates the available intake and discharge locations for both supply air and exhaust air.

	Bottom	Top	Side	End
OA Intake		X		X
OA Discharge*	X	X		X
Exhaust Intake	X	X		X
Exhaust Discharge		X	X	X

* ERCH models with Indirect Gas (IG) heater must use Bottom OA Discharge.

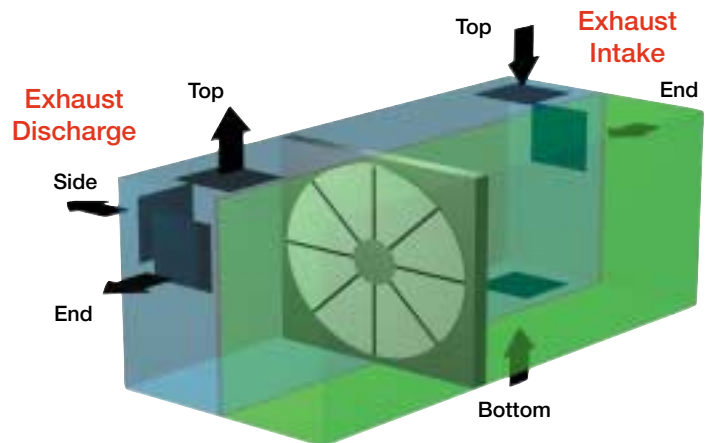
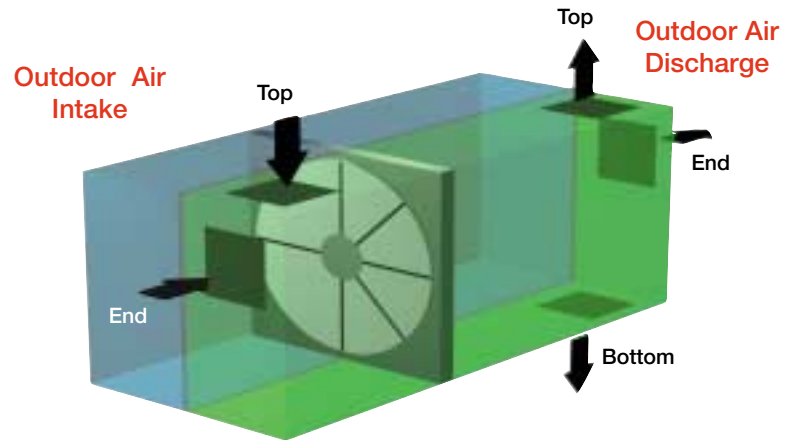

Dampers - Internally Mounted

A wide variety of dampers are available in either gravity or motorized operation. Intake dampers are internally mounted at the outdoor air inlet and are factory wired. Exhaust dampers are located at the exhaust outlet and may be factory mounted or shipped loose. Night setback damper is available for mounting between supply and exhaust airstream to allow air recirculation during unoccupied mode.

Filters

Standard size 2 inch pleated, medium efficiency filters and filter racks are available for outdoor air and/or exhaust air streams.

Model	Filter Size	Quantity
ERCH-20	20 x 20	2
ERCH-45	20 x 25	3
ERCH-55	16 x 20	6
ERCH-90	20 x 20	8

Painted Exteriors

Greenheck's Permator® coating is available for a durable, long lasting finish. Decorative paints are available in a variety of colors to match existing building fixtures. Consult your Greenheck representative for paint selections.

Roof Curbs

Prefabricated roof curbs are available to ensure compatibility between ventilator, curb and roof opening. Standard construction is galvanized steel. Curbs are supplied with duct adapters. Consult your Greenheck representative for curb outside dimensions and roof openings required.

Variable Speed

Belt drive models are available with two speed motors. Consult your Greenheck representative for variable frequency drives.

Timed Exhaust Frost Control

Timed exhaust frost control turns the supply blower power off and on using field adjustable timer settings when outdoor temperature falls below the frost threshold. The temperature set points are field adjustable with a factory supplied thermostat.

Timed exhaust is appropriate for climates with limited HVAC system operation when outdoor temperatures are below 0°F.

Preheat Frost Control

Preheat frost control enables continuous operation when outdoor temperatures are below the frost threshold. An electric heater warms outdoor air above the frost threshold before it enters the energy recovery wheel. The heater is supplied with a set point that is field adjustable between 0°F and 15°F.

Weather Hoods

A louvered intake hood with 2 inch aluminum mesh filters and exhaust hood with an integral backdraft damper are available.

Dirty Filter Sensors

Pressure taps sense excessive pressure drop across the filter and send a signal to a dirty filter indicator light. Light and control box are available from the factory.

Rotation Sensors

The sensor monitors wheel rotation. A signal may be sent to the remote indicator light. Light and control box are available from the factory.

Economizer Mode

The energy recovery wheel may be de-energized for the purpose of providing economizer (free cooling) operation. Two factory installed options are available.

- **Temperature Sensor:** De-energizes wheel when outdoor temperature is below the field adjustable set point.
- **Enthalpy Sensor:** De-energizes wheel when outdoor enthalpy is below the field adjustable set point.

In addition to the outdoor air sensors, summer/winter change-over logic should be employed. Greenheck provides two methods to override economizer operation during the winter season.

Automatic Override: A factory installed temperature sensor monitors outdoor air. Economizer mode is deactivated when the temperature falls below the field adjustable set point.

Remote Switch: A switch on a remote panel enables manual control of summer/winter change-over.

Note: Control centers in Greenheck energy recovery ventilators enable control of the energy wheel and fans via 24 volt control signals by others. Control by others may be preferred when air handling units are equipped with an economizer section.

Additional accessories:

- GFCI Service Outlet (wiring by others)
- Service Lights (wiring by others)
- Sensible Wheel Only
- Remote Panels
- Spare Wheel Segments
- Duct Flanges
- Temperature Control Package

General: Energy Recovery Ventilator shall be as manufactured by "Greenheck" or approved equal provided all specifications are met. Greenheck Model ERCH is used as the basis of design. Units shall be listed per UL1812 and bear the UL label. Energy transfer ratings shall be ARI Certified. Performance shall be as scheduled on plans. Exhaust discharge and outside air intake shall not be located on the same side on roof top units.

Unit Casing and Frames: Unit shall be of internal frame type construction of galvanized steel. Frame and panels shall be G90 galvanized steel. All panels exposed to the weather shall be a minimum of 18 gauge galvanized steel. Unit shall be internally lined with galvanized sheet metal creating a double wall. Where top panels are joined there shall be a standing seam to insure positive weather protection. All metal-to-metal seams shall be sealed, requiring no caulking at job site. Permatector® exterior finish is available for outdoor units. Unit base to be designed for curb mounting. Unit base shall over hang the curb for a positive seal against water run-off.

Weatherhoods: Weatherhoods shall be the same finish as the unit. Outdoor air weatherhood shall incorporate a louvered design and moisture eliminator. Weatherhoods shall be tested in accordance with AMCA Standard 500-L to prevent water penetration up to 3 in/hr at 29 mph.

Insulation: Unit casing to be insulated with 1 inch fiberglass. Insulation shall meet requirements of NFPA 90A and tested to meet UL 181 erosion requirements. Insulation to be enclosed in double wall construction.

Energy Recovery Wheel: Wheel shall be of the enthalpy type for both sensible and latent heat recovery and be designed to insure laminar flow. Energy transfer ratings must be ARI Certified to Standard 1060. Ratings "in accordance with 1060" without certification are not acceptable. Desiccant shall be silica gel for maximum latent energy transfer. Wheel shall be constructed of lightweight polymer media to minimize shaft and bearing loads. Polymer media shall be mounted in a stainless steel rotor for corrosion resistance.

Wheel design shall consist of removable segments for ease of service and/or cleaning. Silica gel desiccant shall be permanently bonded to wheel media to retain latent heat capability after cleaning. Wheels with sprayed on desiccant coatings are not acceptable. Wheels with desiccant applied after wheel formation are not acceptable. Energy recovery device shall transfer moisture entirely in the vapor phase.

Access Doors: All components shall be easily accessible through removable doors for exhaust, supply, filter, and damper compartments. Energy recovery wheels (smaller than 54 inches) shall be mounted in a slide-out track for ease of inspection, removal, and cleaning.

Roof Curbs: Roof curb to be supplied by unit manufacturer for field assembly. Curb shall consist of die formed galvanized steel sections. Curb shall be full perimeter type with gasketing provided for field installation between curb and unit base.

Fan Sections: Centrifugal fans to be double width, double inlet, forward curved type. All blower wheels shall be statically and dynamically balanced. Ground and polished steel fan shafts shall be mounted in permanently lubricated, sealed ball bearing pillow blocks. Bearings shall be selected

for a minimum (L10) life in excess of 100,000 hours at maximum cataloged operating speeds. Separate motors for exhaust and supply blowers shall be provided. Adjustable sheaves on belt-driven fans with motors less than 10 hp shall allow independent balancing of exhaust and supply airflow. Fan and motor assemblies are mounted to unit base with neoprene isolators as standard. Fans shall be located in draw-through position in reference to the energy recovery wheel.

Motors and Drives: Motors shall be energy efficient, complying with EPACT standards, for single speed ODP and TE enclosures. Motors shall be permanently lubricated, heavy-duty type, matched to the fan load and furnished at the specified voltage, phase, and enclosure. Drives shall be sized for a minimum of 150% of driven horsepower. Pulleys shall be of the fully machined cast type, keyed and securely attached to the fan wheel and motor shafts; 10 horsepower and less shall be supplied with an adjustable drive pulley. Energy wheel motors shall have integral overload protection.

Filters: Supply and exhaust air filters shall be 2-inch thick pleated fiberglass, 30% efficient and tested to meet UL Class 2. Filter racks shall be die-formed galvanized steel.

Electrical: All internal electrical components shall be factory wired for single point power connection. Units with electric reheat will be wired with independent power supply. All electrical components shall be UL Listed, Approved or Classified where applicable and wired in compliance with the National Electrical Code.

Weatherproof, integral door interlocking disconnect switch, motor starters, control circuit fusing, and control transformer for 24 VAC circuit shall be supplied as standard components in the control center. Motor starters consist of a contactor and Class 20 electronic adjustable overload protection and shall be provided for all motors in the unit.

Cooling Coil: Direct expansion (DX) and chilled water coils shall be factory tested and rated in accordance with ARI 410. Coils shall have copper tubes with permanently expanded aluminum fins, 12 fpi or less. DX coils shall be equipped with distributors to receive expansion valves at the liquid connections.

Indirect Gas: Indirect fired gas furnace shall be 80% efficient, UL Certified per ANSI Z83.8 - 1996, C.G.A. approved per 2.6 - M96 and have a blow through fan design. Furnace shall be capable of operation with natural gas and have a power venting system. The burner and heat exchanger shall be constructed of aluminized steel. Standard furnace features shall include pressure switch, main gas valve, electronic staged, electronic intermittent pilot ignition, high limit and a 24-volt control transformer.

Hot Water Coil: Hot water coil shall be factory tested and rated in accordance with ARI 410. Coils shall have copper tubes with permanently expanded aluminum fins, 12 fpi or less.

Electric Heat: Electric heat shall be UL listed and circuit fused per NEC over 48 amps. Heater shall be multi-step control, factory wired and installed. Control will be 24 volt with class 2 transformer. Standard air flow switch to shut down heater if air ceases to flow across heater.

Warranty: Refer to the warranty statement on the back page of the Model ERCH catalog.

Unit Size	A	B	C	D	E	F
ERCH-20	98	50	56	18	18	9
ERCH-45	106	69	66	16	20	11
ERCH-55	118	70	76	16	25	11
ERCH-90	131	85	96	16	27	11

All dimensions shown are in inches.

Unit Size	Approximate Weight (lbs)
ERCH-20	1500
ERCH-45	2300
ERCH-55	3000
ERCH-90	5000

Consult your Greenheck Representative for specific weights.

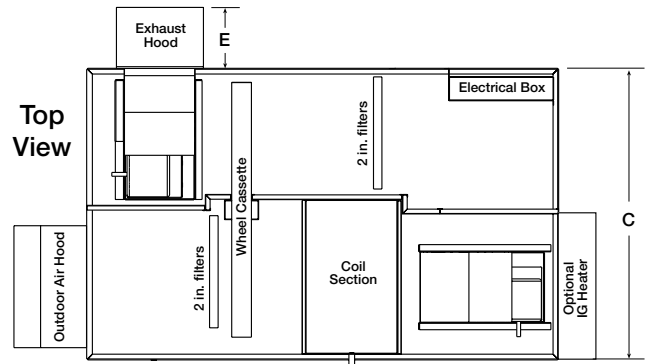
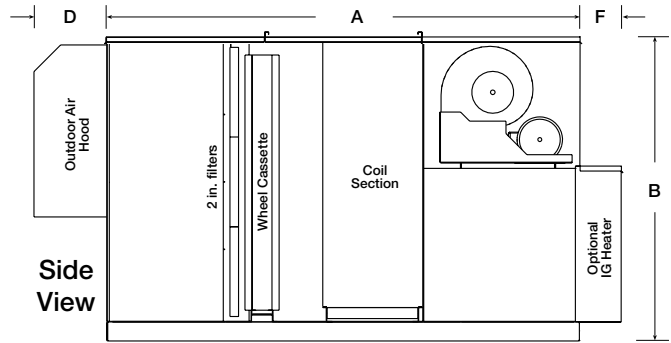

Warranty

Greenheck warrants this equipment to be free from defects in material and workmanship for a period of one year from the purchase date. The energy recovery wheel is warranted to be free from defects in material and workmanship for a period of five years from the purchase date. Any units or parts which prove defective during the warranty period will be replaced at our option when returned to our factory, transportation prepaid.

Motors are warranted by the motor manufacturer for a period of one year. Should motors furnished by Greenheck prove defective during this period, they should be returned to the nearest authorized motor service station. Greenheck will not be responsible for any removal or installation costs.

Due to continuing research, Greenheck reserves the right to change specifications without notice.



Number one in air movement and control.



Centrifugal and Vane Axial Fans



Fans and Ventilators



Energy Recovery Ventilators & Make-Up Air Units



Kitchen Ventilation Systems

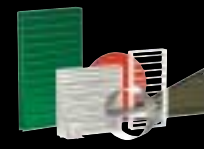

Dampers and Louvers

Visit the Greenheck website for the most current information available
www.greenheck.com

Greenheck • P.O. Box 410 Schofield, WI 54476-0410 • Phone (715) 359-6171 • Fax (715) 355-2399 • www.greenheck.com