

Application and Design

EADC-601 is a weather louver designed to protect air intake and exhaust openings in building exterior walls that require tight air shut off. Design incorporates drain gutters in the head member and horizontal blades to channel water to the louver side frames or jambs where water is further channeled through vertical downspouts and out at the sloped louver sill. The adjustable blades are always motorized. The actuator is concealed in the sill member.

Standard Construction

- Frame: Heavy gauge 6063T5 extruded aluminum, 6" x .125" nominal dimensions
- Blades: Drainable design, 6063T5 extruded aluminum, .081" nominal wall thickness, positioned at 45° angle on approximately 6" centers
- Seals: Extruded dual-durometer vinyl blade seals - compressible stainless steel jamb seals
- Linkage: Side linkage out of airstream (concealed in frame)
- Bearings: Synthetic sleeve type
- Axles: 1/2" diameter zinc plated steel
- Birdscreen: 3/4" x .051" flattened expanded aluminum in removable frame. Screen is mounted on inside (rear)
- Finish: Mill
- Minimum Size: 18"W x 30"H
- Maximum Size: 60"W x 96"H (see page 4) without seals
42 x 96 with seals
60 x 74 with seals

Options (at additional cost)

- Flanged frame
- Extended sill
- A variety of bird and insect screens
- A variety of architectural finishes including:
 - Clear anodize
 - Integral color anodize
 - Baked enamel
 - Kynar
- Hinged frame
- Security bars
- Filter racks

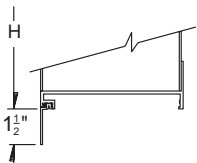
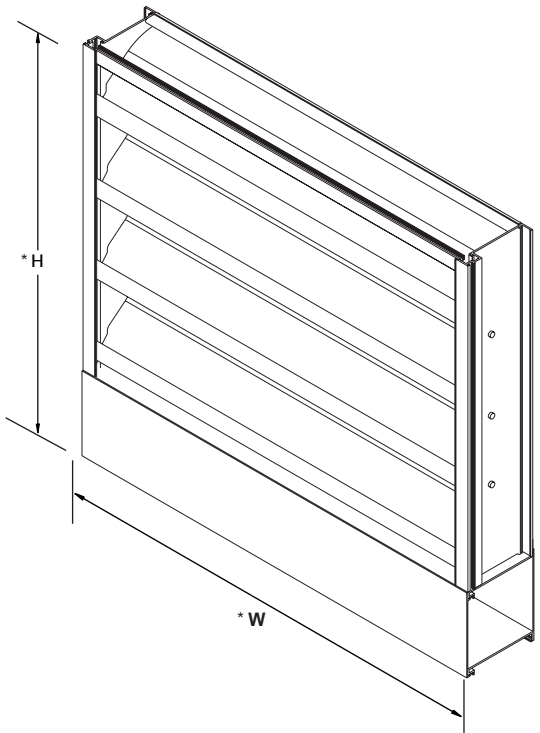
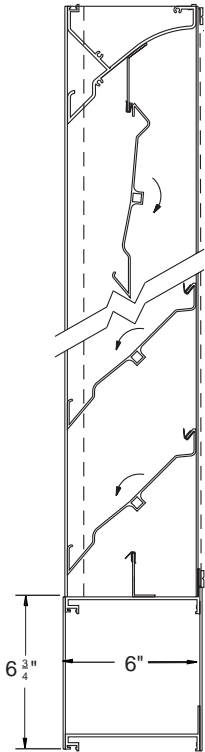

OPTIONAL FLANGE

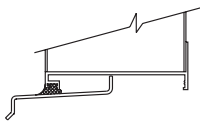

OPTIONAL EXTENDED SILL

* W & H Dimensions furnished approximately 1/4" under size.

Quantity	Size		
	W Width	H Height	
Project			Location
Contractor			Architect/Engineer

EADC-601 Louver Performance Data

Airflow Resistance (Standard Air - .075 lb/ft³)

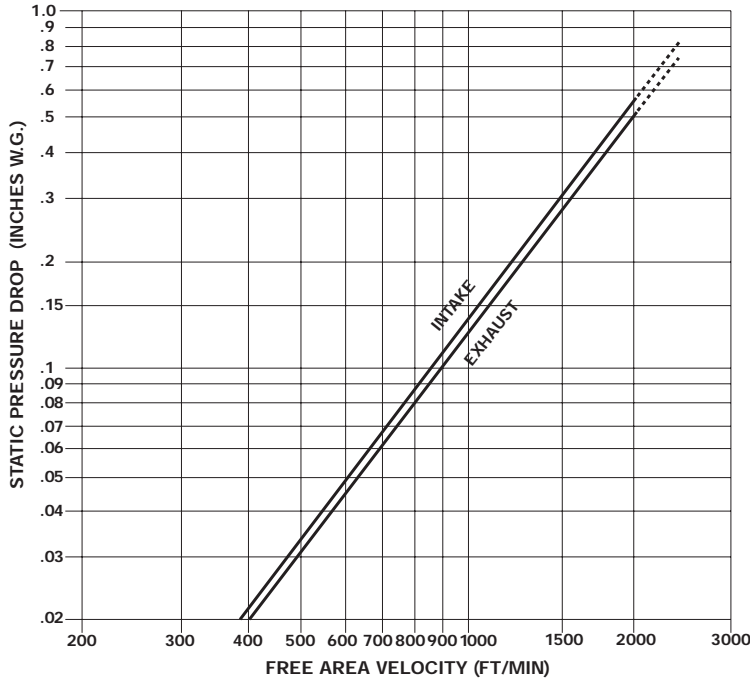

Model EADC-601 resistance to airflow varies depending on louver application (air intake or air exhaust). Free area velocities (shown) are higher than average velocity through the overall louver size. See louver selection information.

Air Leakage

Maximum intake mode air leakage through Model EADC-601 at 0.5 in. w.g. ΔP (32 mph wind equivalent) is less than 4.0 cfm/ft of louver area. This is based on a minimum of 5 in. lbs. of torque applied per sq. ft. of louver face area to hold this louver in the closed position.

Water Penetration (Standard Air - .075 lb/ft³)

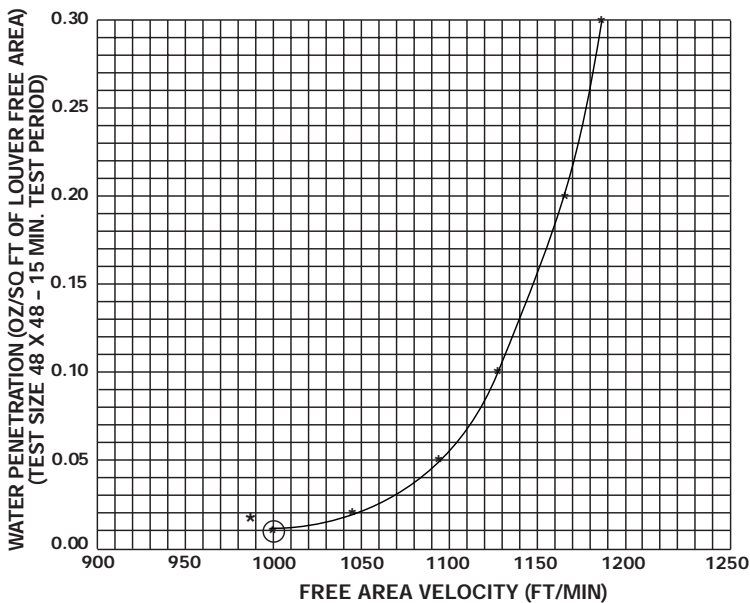

The AMCA Water Penetration Test provides a method for comparing various louver models and designs as to their efficiency in resisting the penetration of rainfall under specific laboratory test conditions. The beginning point of water penetration is defined as that velocity where the water penetration curve projects through .01 oz. of water (penetration) per sq. ft. of louver free area. ***The beginning point of water penetration for Model EADC-601 is 1007 fpm free area velocity.** These performance ratings do not guarantee a louver to be weatherproof or stormproof and should be used in combination with other factors including good engineering judgement in selecting louvers.

Louver Selection and Application

Application of any louver involves selecting an airflow velocity through the louver free area (free area velocity in fpm) that produces an acceptable pressure drop and for intake applications minimizes carry through of normally encountered rain water.

No louver manufacturer warrants their louver to prevent water penetration under all possible combinations of wind and rain. Water penetration through Model EADC-601 begins at 1007 fpm free area velocity. Intake air louver selection using free area velocity below 1007 fpm is recommended. Louver selection involves the following two steps, and depending on given conditions, either step may come first.

Select Free Area Velocity:

Using the **Airflow Resistance Chart**, select a free area velocity that produces an acceptable pressure drop with minimal water penetration. (Water penetration need not be considered when selecting exhaust louvers.)

Determine Louver Free Area:

Using the free area velocity from previous step and total cfm, determine Louver Free Area required. Using **Louver Free Area Chart**, select a louver with the required free area. If louver size is given, determine free area from chart and work backwards to determine maximum airflow. See examples below.

Free Area Chart

Louver Height Inches	Louver Width in Inches															Louver Height Inches
	18	21	24	27	30	33	36	39	42	45	48	51	54	57	60	
30	0.99	1.18	1.37	1.56	1.75	1.94	2.13	2.32	2.51	2.7	2.9	3.09	3.28	3.47	3.66	30
33	0.99	1.18	1.37	1.56	1.75	1.94	2.13	2.32	2.51	2.7	2.9	3.09	3.28	3.47	3.66	33
36	1.39	1.66	1.93	2.2	2.46	2.73	3	3.27	3.54	3.81	4.08	4.35	4.61	4.88	5.15	36
39	1.39	1.66	1.93	2.2	2.46	2.73	3	3.27	3.54	3.81	4.08	4.35	4.61	4.88	5.15	39
42	1.79	2.14	2.48	2.83	3.18	3.52	3.87	4.22	4.57	4.91	5.26	5.61	5.95	6.3	6.65	42
45	1.79	2.14	2.48	2.83	3.18	3.52	3.87	4.22	4.57	4.91	5.26	5.61	5.95	6.3	6.65	45
48	2.19	2.62	3.04	3.47	3.89	4.32	4.74	5.17	5.59	6.02	6.44	6.86	7.29	7.71	8.14	48
51	2.19	2.62	3.04	3.47	3.89	4.32	4.74	5.17	5.59	6.02	6.44	6.86	7.29	7.71	8.14	51
54	2.6	3.1	3.6	4.1	4.61	5.11	5.61	6.11	6.62	7.12	7.62	8.12	8.63	9.13	9.63	54
57	2.6	3.1	3.6	4.1	4.61	5.11	5.61	6.11	6.62	7.12	7.62	8.12	8.63	9.13	9.63	57
60	3	3.58	4.16	4.74	5.32	5.9	6.48	7.06	7.64	8.22	8.8	9.38	9.96	10.54	11.12	60
63	3	3.58	4.16	4.74	5.32	5.9	6.48	7.06	7.64	8.22	8.8	9.38	9.96	10.54	11.12	63
66	3.4	4.06	4.72	5.38	6.03	6.69	7.35	8.01	8.67	9.33	9.98	10.64	11.3	11.96	12.62	66
69	3.4	4.06	4.72	5.38	6.03	6.69	7.35	8.01	8.67	9.33	9.98	10.64	11.3	11.96	12.62	69
72	3.4	4.06	4.72	5.38	6.03	6.69	7.35	8.01	8.67	9.33	9.98	10.64	11.3	11.96	12.62	72
75	3.8	4.54	5.28	6.01	6.75	7.48	8.22	8.96	9.69	10.43	11.17	11.9	12.64	13.37	14.11	75
78	3.8	4.54	5.28	6.01	6.75	7.48	8.22	8.96	9.69	10.43	11.17	11.9	12.64	13.37	14.11	78
81	4.21	5.02	5.83	6.65	7.46	8.28	9.09	9.91	10.72	11.53	12.35	13.16	13.98	14.79	15.6	81
84	4.21	5.02	5.83	6.65	7.46	8.28	9.09	9.91	10.72	11.53	12.35	13.16	13.98	14.79	15.6	84
87	4.61	5.5	6.39	7.28	8.18	9.07	9.96	10.85	11.75	12.64	13.53	14.42	15.31	16.21	17.1	87
90	4.61	5.5	6.39	7.28	8.18	9.07	9.96	10.85	11.75	12.64	13.53	14.42	15.31	16.21	17.1	90
93	5.01	5.98	6.95	7.92	8.89	9.86	10.83	11.8	12.77	13.74	14.71	15.68	16.65	17.62	18.59	93
96	5.01	5.98	6.95	7.92	8.89	9.86	10.83	11.8	12.77	13.74	14.71	15.68	16.65	17.62	18.59	96

Louver Free Area in Square Feet

EADC-601 Selection and Examples

Example 1:

Airflow given as 10,000 cfm – select louver size.

- A. Determine louver free area by dividing airflow by free area velocity (do not exceed 1007 fpm on intake louver application).

$$\frac{10,000 \text{ cfm}}{\text{Airflow}} \div \frac{1007 \text{ fpm}}{\text{Free Area Velocity}} = \frac{9.9 \text{ ft.}^2}{\text{Required Louver Free Area}}$$

- B. Select a louver with at least the required louver free area from **Free Area Chart** above.

$$\frac{48'' \text{ W} \times 72'' \text{ H}}{9.98 \text{ ft.}^2 \text{ free area}}$$

$$\frac{1002 \text{ fpm free area velocity (10,000 cfm} \div 9.98 \text{ ft.}^2 \text{ F.A.)}}{\text{Free Area Velocity}}$$

(Other selections available – See **Free Area Chart** above.)

- C. Check the pressure drop of the selected louver at the given airflow (**Airflow Resistance Chart** on Page 2).

$$\Delta P \text{ at } \frac{1002 \text{ fpm}}{\text{Free Area Velocity}} = \frac{0.135 \text{ in. w.g.}}{\text{Pressure Drop}}$$

Example 2:

Louver size given as 48 x 48 – determine maximum airflow.

- A. Use **Free Area Chart** to determine Free Area = 6.44 ft.²

- B. Multiply Free Area x Free Area Velocity (Do not exceed 1007 fpm on intake louver applications).

$$\frac{6.44 \text{ ft.}^2 \times 1007 \text{ fpm}}{\text{Free Area} \quad \text{Free Area Velocity}} = \frac{6485 \text{ cfm}}{\text{Maximum Airflow}}$$

- C. Check the pressure drop of the selected louver at the given airflow (**Airflow Resistance Chart** on Page 2).

$$\Delta P \text{ at } \frac{1007 \text{ fpm}}{\text{Free Area Velocity}} = \frac{0.140 \text{ in. w.g.}}{\text{Pressure Drop}}$$

Maximum Size and Installation Information

Because of Model EADC-601's adjustable drainable blade design, the width is limited to a maximum of 60" and height of 96". Shipping and handling restraints further dictate that maximum section sizes be limited to 60"W x 96"H. Factory-assembled louver sections are designed to withstand wind loadings of 25 pounds per square foot (100 mph wind equivalent), however, louver frames and hidden mullions require bracing or support from the building structure to provide overall structural integrity. If larger louver assemblies are to be field erected, section joints also require bracing or support from the building structure. Angles, clips, bolts, and other fasteners and installation hardware are not provided with the louvers and must be supplied by the installing contractor. Details shown are general in nature. Additional information on louver installation may be found in AMCA Publication #501, Louver Application Manual.

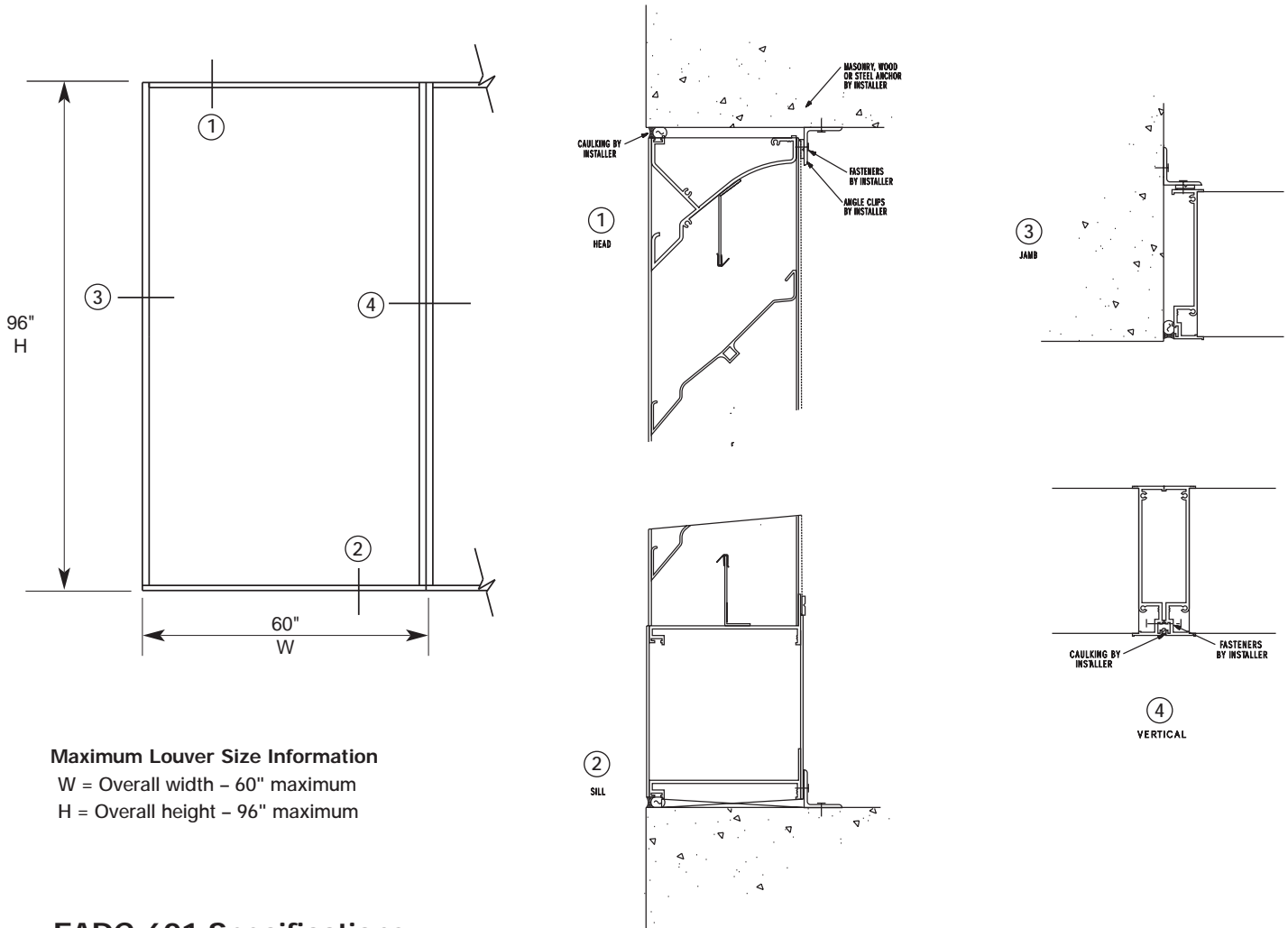

Maximum Louver Size Information

W = Overall width - 60" maximum

H = Overall height - 96" maximum

EADC-601 Specifications

Louvers meeting the following specifications shall be furnished and installed where shown on the plans and/or as described in schedules. Louvers shall be adjustable type with drainable blades in a 6" louver frame. The headpiece and each adjustable blade shall incorporate an integral drain gutter and each jamb shall incorporate an integral downspout so water drains to blade end, then down the downspouts and out at the louver sill rather than cascading from blade to blade.

Each factory-assembled louver section shall be designed to withstand wind loadings of 25 pounds per square foot (100 mph wind equivalent). Louver frames, mullions, and section joints shall be adequately supported from the building structure to withstand this same wind loading.

Louvers shall be Greenheck Model EADC-601 adjustable drainable type fabricated from 6063T5 aluminum extrusions of .081" nominal

wall thickness. Blades shall be positioned approximately on 6" centers. Each louver shall be equipped with a framed, removable, rear-mounted screen of 3/4" x .051" expanded, flattened aluminum. The actuator will be concealed in the sill member.

Specifier select one of the following finish specifications:

Louvers shall be supplied with standard mill finish.

Louvers shall be supplied with a baked enamel finish applied after a thorough cleaning and preparation of the metal surface. A total dry film thickness of approximately 1.2 mils shall be provided. Color shall be (specify color from standard color chart).

Louvers shall be supplied with a Kynar finish applied following a thorough cleaning and pretreatment of the metal surface. Dry film thickness of the Kynar shall be approximately 1.2 mils after baking at 450°F. Color shall be (specify color from standard color chart).