

Application

Model DFD-21 is a multi-blade fire damper with 3 Vee style blades. While the DFD-21 has been qualified to 2500 fpm and 8 in. wg. for dynamic closure in emergency fire situations. Model DFD-21 may be installed vertically (with blades running horizontal) or horizontally and is rated for airflow in either direction.

Ratings

UL 555 Fire Resistance Rating

Fire Rating:	1 1/2 Hours
Dynamic Closure Rating:	Actual limits are size dependent
Maximum Velocity:	2500 fpm
Maximum Pressure:	8 in. wg

Model DFD-21 is intended for installation in accordance with fire damper requirements established by:

National Fire Protection Association
 NFPA Standards 90A & 101
BOCA National Building Codes
ICBO Uniform Building Codes
IBC International Building Codes
SBCCI Standard Building Codes
CSFM California State Fire Marshal
 Fire Damper Listing (#3225-0981:103)
New York City (MEA listing #260-91-M)

Standard Construction

Frame:	5 in. x 1 in. 16 gauge galvanized steel hat channel with reinforced corners. A low profile head and sill are used on sizes less than 17 in. high to maximize free area and performance.
Blades:	16 gauge galvanized steel, reinforced with 3 longitudinal structurally designed vee's.
Seals:	Flexible stainless steel jamb seals.
Linkage:	Concealed in jamb.
Fusible Link:	UL listed 165°F.
Axles:	1/2 in. dia. plated steel.
Bearings:	Bronze sleeve type.
Actuator:	Manual quadrant.

"UL CLASSIFIED (see complete marking on product)"
"UL CLASSIFIED to Canadian safety standards (see complete marking on product)"
 Standard 555 (Listing #R13317)



Greenheck certifies that the model DFD-21 shown herein is licensed to bear the AMCA Seal. The ratings shown are based on tests and procedures performed in accordance with AMCA Publication 511 and comply with the requirements of the AMCA Certified Ratings Programs.



Size Limitations

Minimum Size:	8 in. W x 6 in. H
Maximum Size:	Single Section: 42 in. W x 60 in. H Multiple Section: 96 in. W x 50 in. H Vertical Only: 128 in. W x 100 in. H

Optional Features

- Stainless steel bearings
- OCI (Open Closed Indication switches)
- 212° F, 286° F, and 350° F fuse links
- Factory mounted sleeves
- Round and oval transitions
- Retaining angles

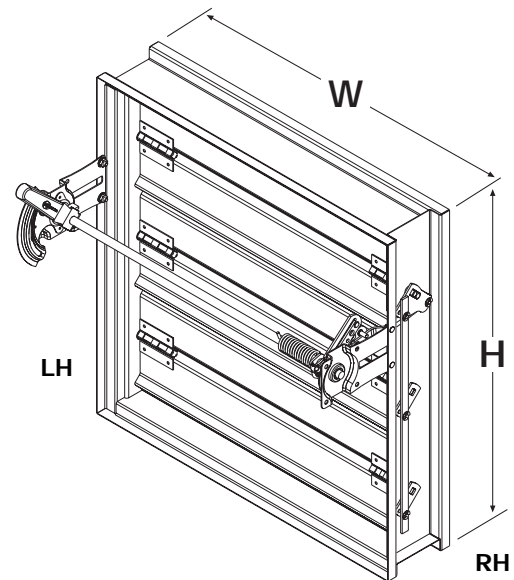

* W & H dimensions furnished approximately 1/4 in. undersize. (Add sleeve thickness for overall sleeved damper dimension)

Installation and Maintenance

Refer to Greenheck Installation Instructions: Part #453402

Dampers must be maintained, cycled, and tested at intervals not less than every twelve months and in accordance with:

- The latest editions of NFPA 90A and UL 864 unless local codes require more frequent inspections.

This pressure drop testing was conducted in accordance with AMCA Standard 500 using the three configurations shown. All data has been corrected to represent standard air at a density of 0.075 lb/ft³.

Actual pressure drop found in any HVAC system is a combination of many factors. This pressure drop information along with an analysis of other system influences should be used to estimate actual pressure losses for a damper installed in a given HVAC system.

AMCA Test Figures

Figure 5.3 Illustrates a fully ducted damper. This configuration has the lowest pressure drop of the three test configurations because entrance and exit losses are minimized by straight duct runs upstream and downstream of the damper.

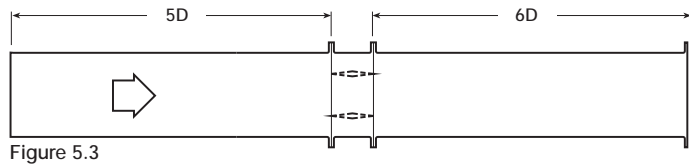

Figure 5.3

Figure 5.2 Illustrates a ducted damper exhausting air into an open area. This configuration has a lower pressure drop than Figure 5.5 because entrance losses are minimized by a straight duct run upstream of the damper.

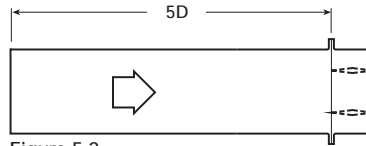

Figure 5.2

$$D = \sqrt{\frac{4(W)(H)}{3.14}}$$

Figure 5.5 Illustrates a plenum mounted damper. This configuration has the highest pressure drop because of extremely high entrance and exit losses due to the sudden changes of area in the system.

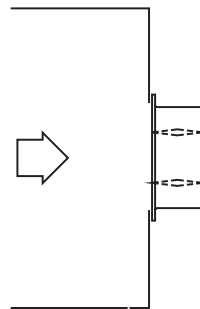

Figure 5.5

Pressure Drop Calculations

As explained in chapter 32 of the 1997 ASHRAE fundamentals handbook, pressure drop is a function of two variables: pressure velocity and a dimensionless parameter called the pressure loss coefficient (C_o).

To calculate the pressure drop across your damper: first select the AMCA test figure shown above that most closely resembles how your damper will be mounted, then substitute the duct face velocity and the appropriate damper pressure loss coefficient (C_o) found on the following page into equation 1.

Equation 1: $\Delta p = C_o * (V / 4005)^2$

- Δp = pressure drop measured in inches wg
- C_o = pressure drop coefficient
- V = Face velocity measured in fpm

Example: Calculate the pressure drop of a 24 in. x 24 in. damper in a fully ducted configuration (fig 5.3) that sees a face velocity of 1500 fpm.

Using the pressure loss coefficient table corresponding to AMCA fig 5.3 it can be seen that the C_o value for a 24 in. x 24 in. damper is 0.65. Substituting C_o and the velocity into equation 1:

$$\Delta p = 0.65 * (1500 / 4005)^2$$

$$\Delta p = 0.091 \text{ in. wg}$$



Greenheck certifies that the model DFD-21 shown herein is licensed to bear the AMCA Seal. The ratings shown are based on tests and procedures performed in accordance with AMCA Publication 511 and comply with the requirements of the AMCA Certified Ratings Programs.

Pressure Loss Coefficient (Co) Table for AMCA Test Figure 5.3

Height	Width									
	8	12	16	20	24	28	32	36	40	42
6	11.74	11.74	6.34	6.34	5.14	5.14	4.63	4.63	4.63	4.30
8	6.34	4.30	4.30	2.41	2.41	2.41	2.41	1.69	1.69	1.69
12	4.30	2.41	1.69	1.32	1.32	1.10	1.10	1.10	1.10	1.10
16	2.41	1.32	1.10	0.90	0.90	0.76	0.76	0.76	0.76	0.65
20	2.41	1.32	1.10	0.90	0.90	0.76	0.76	0.76	0.76	0.76
24	1.69	1.10	0.90	0.76	0.65	0.64	0.64	0.64	0.64	0.64
28	1.69	1.10	0.90	0.76	0.64	0.64	0.64	0.64	0.64	0.64
32	1.69	0.90	0.76	0.64	0.64	0.64	0.51	0.51	0.51	0.51
36	1.32	0.90	0.64	0.64	0.51	0.51	0.51	0.44	0.44	0.42
40	1.32	0.90	0.64	0.64	0.51	0.51	0.51	0.44	0.42	0.42
44	1.32	0.76	0.64	0.64	0.51	0.44	0.42	0.42	0.42	0.42
48	1.32	0.76	0.64	0.51	0.51	0.42	0.42	0.42	0.42	0.42
52	1.32	0.76	0.64	0.51	0.44	0.42	0.42	0.42	0.37	0.37
56	1.32	0.76	0.64	0.51	0.44	0.42	0.42	0.42	0.37	0.37
60	1.10	0.76	0.64	0.51	0.42	0.42	0.42	0.37	0.36	0.36

All dimensions shown are in inches.

Pressure Loss Coefficient (Co) Table for AMCA Test Figure 5.2

Height	Width									
	8	12	16	20	24	28	32	36	40	42
6	12.81	12.81	7.23	7.23	6.07	6.07	5.57	5.57	5.57	5.25
8	7.23	5.25	5.25	3.35	3.35	3.35	3.35	2.48	2.48	2.48
12	5.25	3.35	2.48	1.96	1.96	1.62	1.62	1.62	1.62	1.62
16	3.35	1.96	1.62	1.30	1.30	1.07	1.07	1.07	1.07	0.92
20	3.35	1.96	1.62	1.30	1.30	1.07	1.07	1.07	1.07	1.07
24	2.48	1.62	1.30	1.07	0.92	0.90	0.90	0.90	0.90	0.90
28	2.48	1.62	1.30	1.07	0.90	0.90	0.90	0.90	0.90	0.90
32	2.48	1.30	1.07	0.90	0.90	0.90	0.90	0.75	0.75	0.75
36	1.96	1.30	0.90	0.90	0.75	0.75	0.75	0.66	0.66	0.66
40	1.96	1.30	0.90	0.90	0.75	0.75	0.75	0.66	0.66	0.63
44	1.96	1.07	0.90	0.90	0.75	0.75	0.66	0.63	0.63	0.63
48	1.96	1.07	0.90	0.75	0.75	0.66	0.63	0.63	0.63	0.63
52	1.96	1.07	0.90	0.75	0.66	0.63	0.63	0.63	0.48	0.48
56	1.96	1.07	0.90	0.75	0.66	0.63	0.63	0.63	0.63	0.48
60	1.62	1.07	0.90	0.75	0.63	0.63	0.63	0.48	0.48	0.42

All dimensions shown are in inches.

Pressure Loss Coefficient (Co) Table for AMCA Test Figure 5.5

Height	Width									
	8	12	16	20	24	28	32	36	40	42
6	15.45	15.45	8.35	8.35	7.03	7.03	6.49	6.49	6.49	6.15
8	8.35	6.15	4.36	4.36	4.36	4.36	4.36	3.62	3.62	3.62
12	6.15	4.36	3.62	3.16	3.16	2.83	2.83	2.83	2.83	2.83
16	4.36	3.16	2.83	2.49	2.49	2.21	2.21	2.21	2.02	2.02
20	4.36	3.16	2.83	2.49	2.49	2.21	2.21	2.21	2.21	2.21
24	3.62	2.83	2.49	2.21	2.02	2.00	2.00	1.92	1.90	1.90
28	3.62	2.83	2.49	2.21	2.00	2.00	1.92	1.90	1.90	1.90
32	3.62	2.49	2.21	2.00	1.90	1.90	1.87	1.87	1.87	1.87
36	3.16	2.49	2.00	1.90	1.87	1.87	1.87	1.87	1.87	1.87
40	3.16	2.49	2.00	1.90	1.87	1.87	1.87	1.87	1.87	1.87
44	3.16	2.21	2.00	1.90	1.87	1.87	1.87	1.87	1.87	1.87
48	3.16	2.21	1.92	1.87	1.87	1.87	1.87	1.87	1.87	1.87
52	3.16	2.21	1.90	1.87	1.87	1.87	1.87	1.87	1.87	1.87
56	3.16	2.21	1.90	1.87	1.87	1.87	1.87	1.87	1.87	1.87
60	2.83	2.21	1.90	1.87	1.87	1.87	1.87	1.87	1.87	1.87

All dimensions shown are in inches.

DIMENSIONAL DATA

SPECIFICATIONS

Damper Sizing Information

Dampers larger than maximum single section size are supplied as a factory assembly of two or more sections of equal size. The following figures show maximum damper section size and assembly configurations for multi-section dampers.

All dimensions shown are in inches.

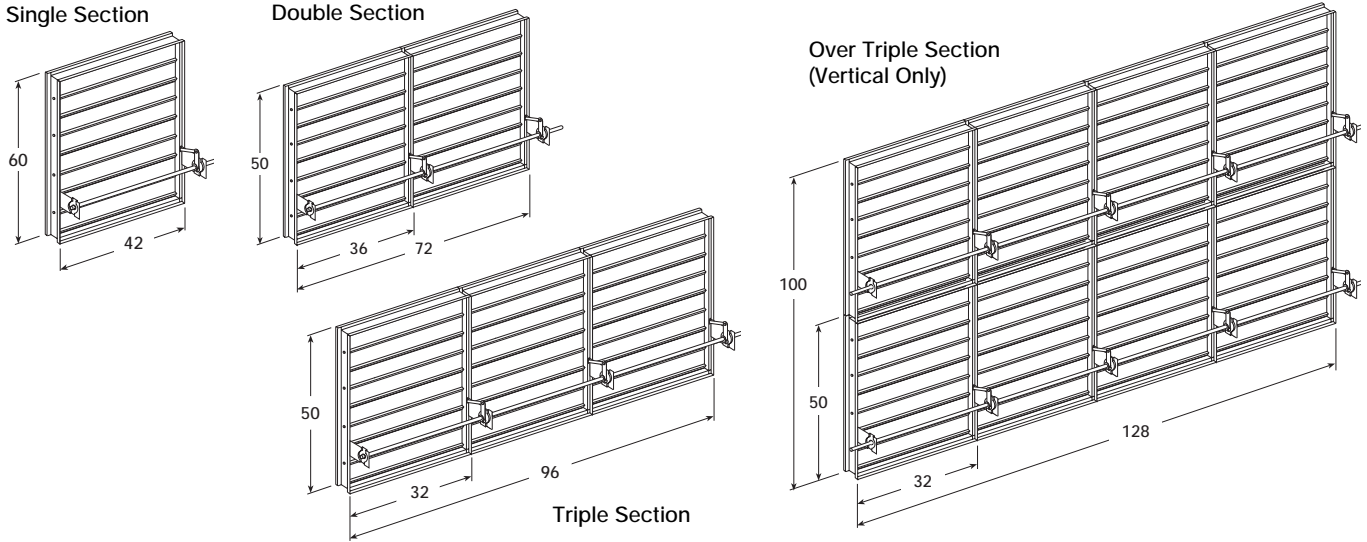

Damper Sleeve Dimensional Data

The drawings below and corresponding table show the position of the DFD-21 damper when mounted in a factory sleeve. The standard mounting locations provide enough space for the mounting of manual quadrant, controls and allow space for installation of retaining angles and duct connections.

The "A" dimension is the location of the damper mounted in a factory sleeve. The table below shows the Standard, Minimum, and Maximum "A" dimensions.

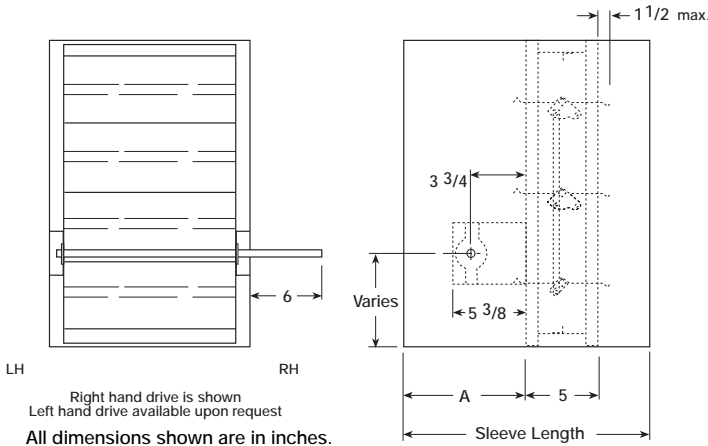

	"A" Dimension		
	Standard	Minimum	Maximum
All Dampers*	7 3/16	5 3/8	12
When H is 10 in. or less w/OCI	11 3/16	C/F	C/F

All dimensions shown are in inches.

* Exception: Dampers 10 in. high or less with OCI option.

Note: Entire damper frame is not required to be installed within the wall. The damper blades, when closed, should be contained within the wall.

Specifications

Fire Dampers meeting the following specifications shall be furnished and installed where shown on plans and/or as described in schedules. Dampers shall meet the requirements of the latest edition of NFPA 90A.

Dampers shall be tested, rated and labeled in accordance with the latest edition of UL Standard 555. Dampers shall have a UL 555 fire rating of 1 1/2 hours. Each damper shall be equipped with a heat responsive device which has been tested and approved for use with the damper assembly in accordance with UL 555. The heat responsive device shall have a temperature rating of (specifier select one of the following) 165°F, 212°F, 286°F, or 350°F. Dampers shall be UL labeled for use in dynamic systems. The damper shall have a dynamic closure pressure rating of 8 in. wg.

Damper actuator shall be manual quadrant. Manufacturers submittal data shall indicate actuator space requirements around the damper.

UL 555 Dynamic Closure Ratings shall be qualified for airflow and pressure in either direction through the damper. UL ratings shall allow for mounting damper vertically (with blades running horizontal) or horizontally.

The Damper Manufacturers submittal data shall certify all air performance pressure drop data is licensed in accordance with the AMCA Certified Ratings

Program for Test Figures 5.2, 5.3 and 5.5. Damper air performance data shall be developed in accordance with the latest edition of AMCA Standard 500-D.

Dampers shall be listed by the California State Fire Marshal. Dampers shall be listed by the New York City Department of Buildings Material and Equipment Acceptance (MEA).

Damper blades shall be 16 gauge galvanized steel 3 Vee type with three longitudinal grooves for reinforcement. Blades shall be completely symmetrical relative to their axle pivot point, presenting identical resistance to airflow and operation in either direction through the damper (blades that are non-symmetrical relative to their axle pivot point or utilize blade stops larger than 1/2 in. are unacceptable).

Damper frame shall be 16 gauge galvanized steel formed into a structural hat channel shape with reinforced corners. Bearings shall be sintered bronze, permanently lubricated, synthetic (acetal) sleeve type rotating in extruded holes in the damper frame for maximum service. Axles shall be square and positively locked into the damper blade. Jamb seals shall be stainless steel compression type.

Basis of design is Greenheck Model DFD-21.



Submittal DFD-21FS
Rev. 1 December 2000
Copyright © 2000 Greenheck Fan Corp.