

Transfer Fan

Model CBF

Cement Block Fan

Model CBF direct drive transfer fans are designed for economy and reliability in small size, high volume applications. Efficient propeller, venturi, and motor design results in low sound levels with minimal restriction to airflow. Works great for ventilating equipment rooms, plumbing and electrical chases.

- Mountable in any wall construction
- Fits in place of a standard 16 by 8 inch concrete block
- Performance to 500 cfm and up to 0.4 in. wg
- UL recognized motors
- Mounting flanges for easy installation



Performance

Model	AMPS		PERFORMANCE IN INCHES WG					
			0.000	0.100	0.125	0.250	0.375	0.400
CBF	1.0	CFM	500	465	453	390	320	300
		Sones	8.3	8.3	8.1	7.8	7.5	9.4

Performance shown is for installation type A: Free inlet, Free outlet.

Dimensions

Model	Width	Height	Length	Grille		Weight
				Width	Height	
CBF	15%	7%	12	18½	10½	17 lbs

All dimensions in inches.

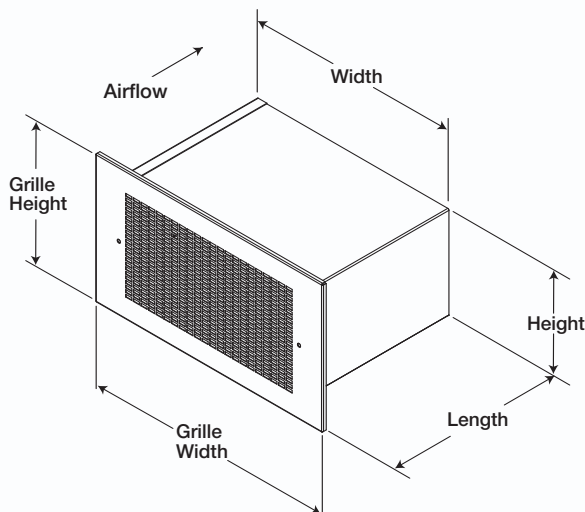

Standard Construction Features

- 1 Corrosion resistant galvanized steel housing
- 2 Tinnerman clips for grille mounting
- 3 Junction box for easy wiring
- 4 Mounting flanges
- 5 Powder coated steel grille

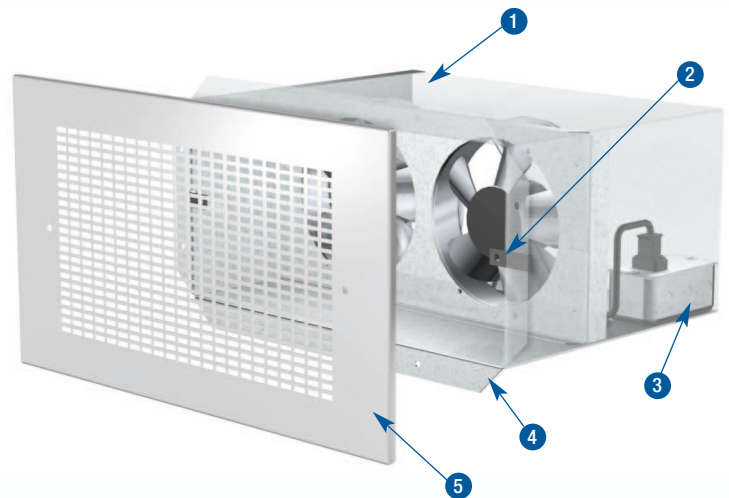

Speed Controllers

Speed controllers are an accessory that provides an economical means of system balancing with direct drive fans.



Typical Specifications

Model CBF Transfer fans shall be dual direct drive axial type. Housing construction shall be galvanized steel. The dual motors shall be permanently lubricated, heavy duty type carefully matched to the fan load. Power pack shall have an internal plug type power connection to facilitate easy removal of the power pack. Power pack assembly shall be removable for ease of installation and cleaning. Grille shall be constructed of steel and powder coated with a white finish. Tinnerman clips shall be used to hold the grille to the housing. Fans shall be Model CBF as manufactured by Greenheck Fan Corporation of Schofield, Wisconsin.



Building Value in Air

Greenheck delivers value to mechanical engineers by helping them solve virtually any air quality challenges their clients face with a comprehensive selection of

top quality, innovative air-related equipment. We offer extra value to contractors by providing easy-to-install, competitively priced, reliable products that arrive on time.

And building owners and occupants value the energy efficiency, low maintenance and quiet dependable operation they experience long after the construction project ends.

Our Warranty

Greenheck warrants this equipment to be free from defects in material and workmanship for a period of one year from the purchase date. Any units or parts which prove defective during the warranty period will be replaced at our option when returned to our factory, transportation prepaid. Motors are warranted by the motor manufacturer for a period of one year. Should motors furnished by Greenheck prove defective during this period, they should be returned to the nearest authorized motor service station. Greenheck will not be responsible for any removal or installation costs. *As a result of our commitment to continuous improvement, Greenheck reserves the right to change specifications without notice.*

