

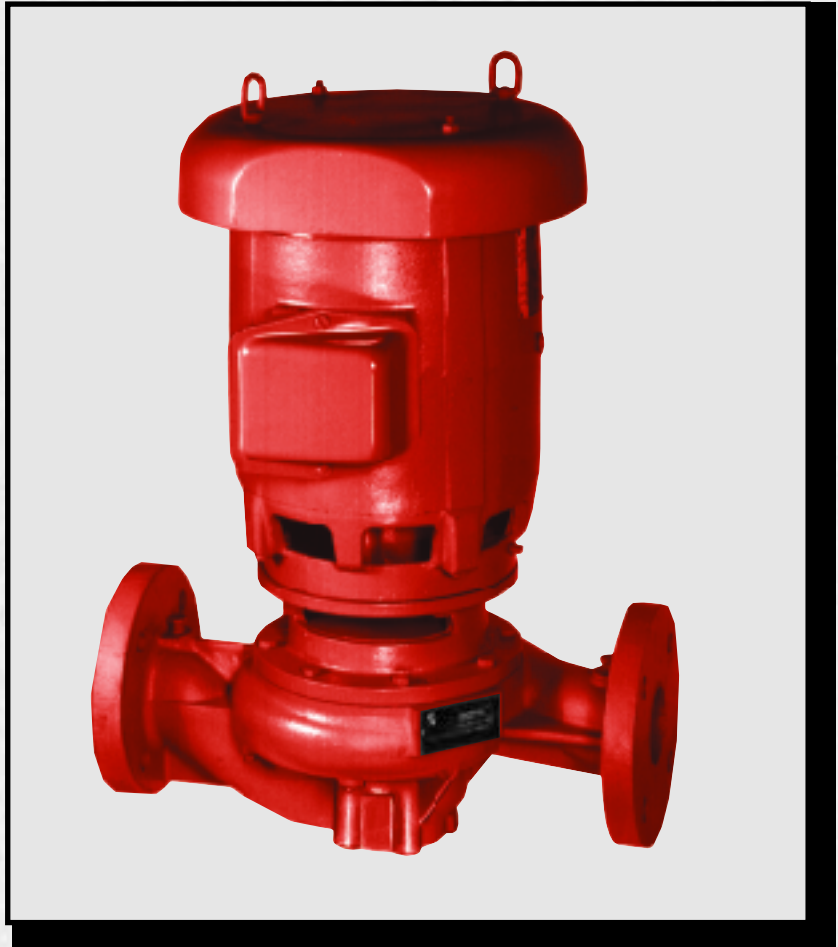

Bell & Gossett



Series 80 In-Line Mounted Centrifugal Pumps

Applications

- Hydronic Heating & Cooling Systems
- Industrial Process
- General Service
- Pressure Boosting

Advantages

- Close Coupled
- Space Saving
- Long Life
- Low Maintenance
- Horizontal or Vertical Installation
- Several Seal Options

Part of the



Equipment Selection Program

Bell & Gossett



ITT Industries
Engineered for life

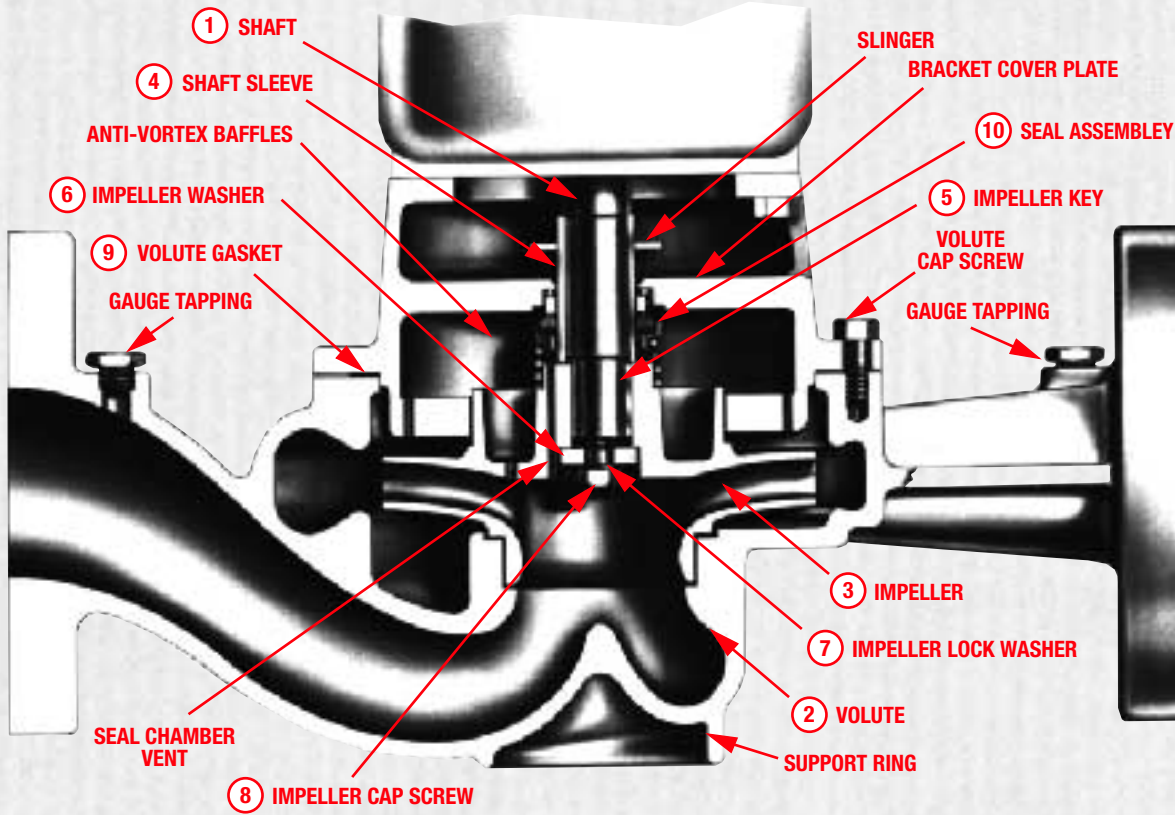

A. STANDARD MECHANICAL SEAL

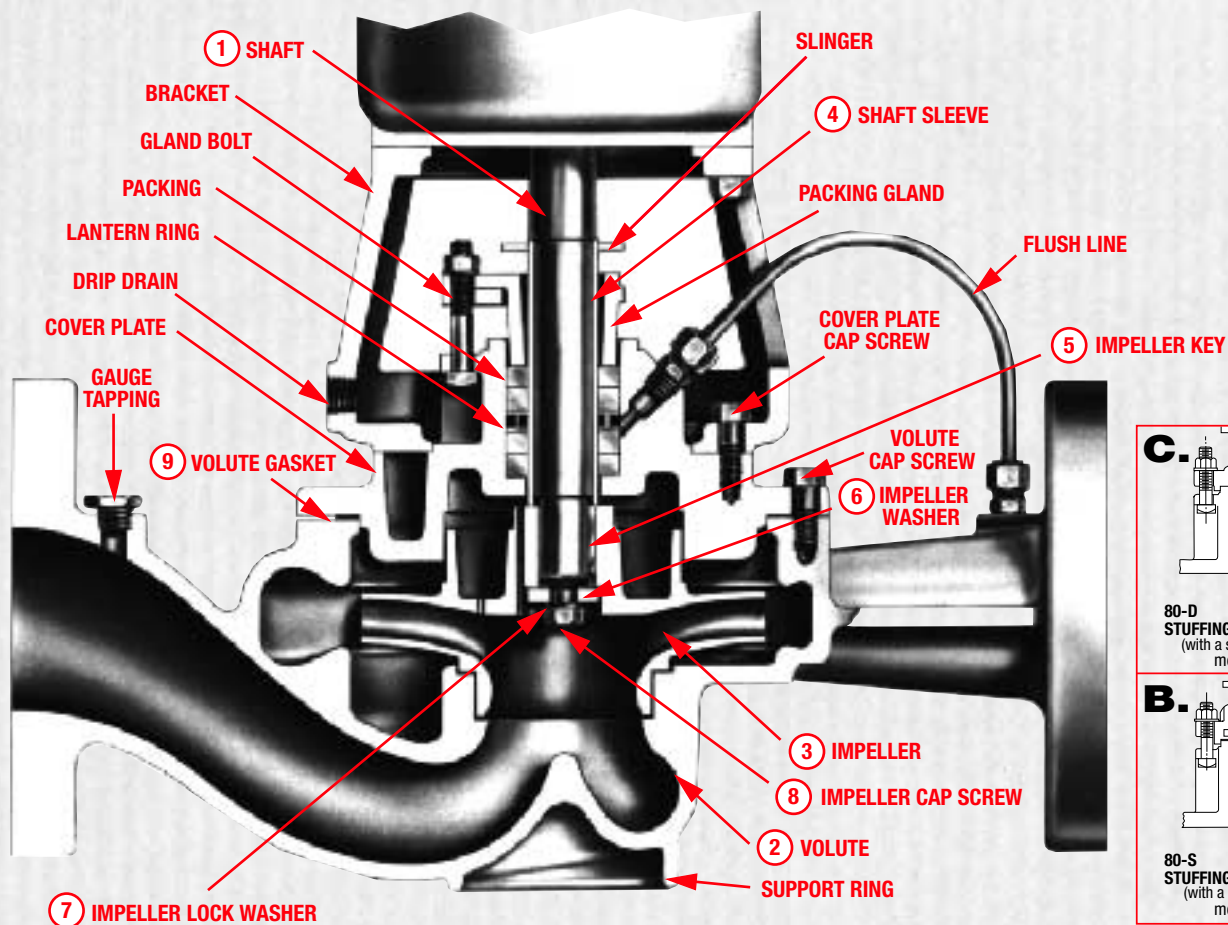

D. 80-PF STUFFING BOX CONSTRUCTION
(with four rings of packing plus a flush RING)

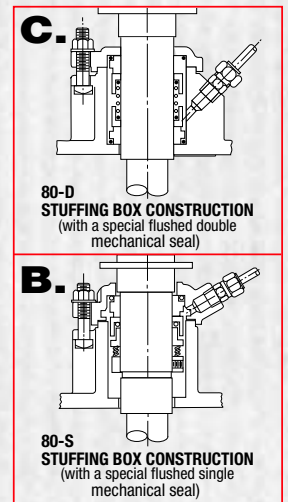

B&G SERIES 80 – AN EFFICIENT RUGGED CLOSE COUPLED PUMP DESIGNED FOR VERTICAL AND HORIZONTAL IN-LINE MOUNTING.

The Series 80 is an efficient, heavy-duty, close coupled pump designed for horizontal and vertical in-line mounting. Available in sizes 1 1/2" through 8". 1/4 to 50 HP at 1750 RPM and 5 to 60 HP at 3500 RPM. Available in bronze fitted and all cast iron construction. Flows to 2500 GPM, heads to 380 ft. Available in 175#, 250# and 300# working pressure designs.

MOTOR BRACKET

Precisely machined rigid cast iron motor bracket ensures positive concentric alignment between motor and pump components. This helps promote maintenance free operation and contributes to pump longevity.

VOLUTE

Standard construction is for 175 psi working pressure, with flanges drilled to mate with 125# ANSI companion flanges. 250 psi and 300 psi working pressure with 250# flange drilling is optionally available.*

MOTORS

Standard NEMA JM and JP vertical solid shaft motors in dripproof enclosures are utilized on B&G Series 80 pumps. High efficiency motors, as well as TEFC and explosion proof enclosures are available options. Motor may be rotated on its bracket at 90° intervals to allow convenient positioning of the junction box.

INTERNALLY FLUSHED MECHANICAL SEAL

The B&G built-in mechanical seal with anti-vortex baffles in the seal chamber provide five times the flow around the seal face versus an externally flushed seal. Costly and inefficient external flush lines are not needed.

CONVENIENT TO INSTALL

In-line mounting eliminates the need for special pads or foundations in most cases. Standard piping supports on both sides of pump are required at all the times. The support ring located on the underside of pump volute is designed to provide ground support when necessary.

HORIZONTAL MOUNTING

Pump may be mounted horizontally in vertical piping if desired.

CONVENIENT TO SERVICE

Back pullout design allows servicing without disturbing the piping. Repairs can be made quickly and easily. Thus down-time is kept to a minimum.

IMPELLER BALANCED TO ANSI/HI GRADE G6.3

Quiet, vibration free operation results from this efficient balancing method. Factory selected diameters ensure that required performance will be attained.

*** 250 psi working pressure requires 80-S construction.
300 psi working pressure requires 80-S construction with silicon carbide seal.**

CONSTRUCTION MATERIALS

(For parts in contact with fluid pumped)

DESCRIPTION	BRONZE FITTED PUMP	ALL IRON PUMP
1. Shaft	Alloy Steel	Alloy Steel
2. Volute	Cast Iron ASTM #A159	Cast Iron ASTM #A159
3. Impeller	Cast Bronze ASTM #B584	Cast Iron ASTM #A159
4. Shaft Sleeve	Aluminum Bronze	#304 Stainless Steel
5. Impeller Key	#304 Stainless Steel	#304 Stainless Steel
6. Impeller Washer	Brass	#304 Stainless Steel
7. Impeller Lock Washer	#304 Stainless Steel	#304 Stainless Steel
8. Impeller Capscrew	#304 Stainless Steel	#304 Stainless Steel
9. Volute Gasket	Cellulose Fiber	Cellulose Fiber
10. Seal Assemblies		
A. Standard Seal		
Bellows	Buna N	Buna N
Faces	Carbon-Ceramic	Carbon-Ceramic
Metal Parts	Brass or Stainless Steel	Stainless Steel
Spring	Stainless Steel	Stainless Steel
For Stuffing Box Design		
B. Flushed Single Seal (80-S)		
O-Rings	EPR	EPR
Faces	Carbon-Tungsten Carbide	Carbon-Tungsten Carbide
Metal Parts	Stainless Steel	Stainless Steel
Spring	Stainless Steel	Stainless Steel
C. Flushed Double Seal (80-D)		
O-Rings	EPR	EPR
Faces	Carbon-Ceramic	Carbon-Ceramic
Metal Parts	Stainless Steel	Stainless Steel
D. Packed Type (80-PF)		
Packing	Impregnated Braided Yarn	Impregnated Braided Yarn
Gland	Bronze	Cast Iron
Lantern Ring	Glass Filled TFE	Glass Filled TFE

SEAL SELECTION GUIDE

A. STANDARD SEALS

Buna-PH Limitations 7-9; Temperature Range -20° to +225°F

EPT-PH Limitations 7-11; Temperature Range -20 to +250°F

For use on open or closed clear water systems.

Maximum working pressure 175 psi.

B. FLUSHED SINGLE SEALS (Stuffing Box Design)

PH Limitations 7-11; Temperature Range -20 to +300°F**

For use on closed or open systems where the temperature or pressure requirements exceed the limitations of the standard seal. Available in 175 psi or 250 psi working pressures.

C. FLUSHED DOUBLE SEALS (Stuffing Box Design)

PH Limitations 7-9; Temperature Range 0 to +250°F

For use on closed or open low pressure systems which may contain a high concentration of abrasives. An external flush is required. Maximum working pressure 175 psi.

D. PACKING (Stuffing Box Design)

PH Limitations 7-9; Temperature Range 0 to +190°F

For use on open or closed systems which require a large amount of make-up water, as well as systems which are subjected to widely varying chemical conditions and solids buildup. Maximum working pressure 175 psi.

****For operating temperatures above 250°F, a cooled flush is required – and is recommended for temperatures above 225°F for optimum seal life. On closed systems, cooling is accomplished by inserting a small heat exchanger in the flush line to cool the fluid.**

Flush-line Filters and Sediment Separators are available on special request.

SELECTION CHARTS

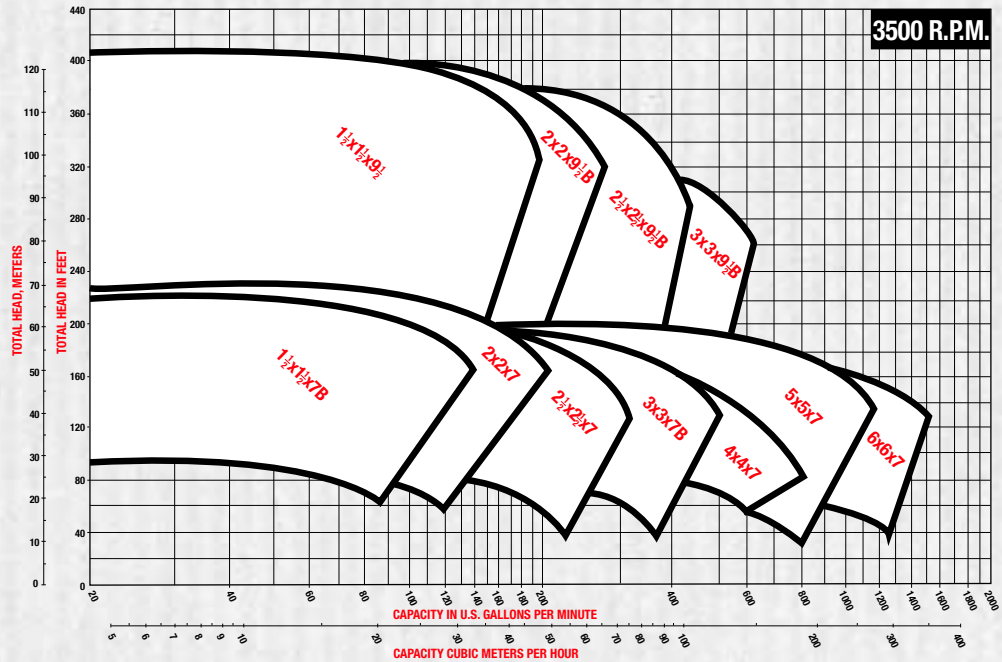
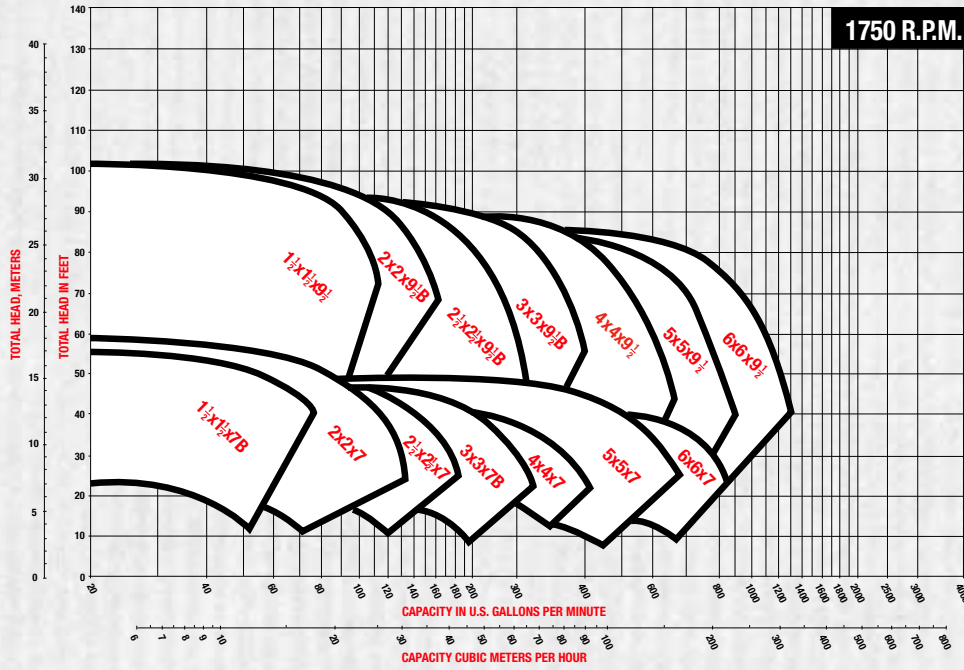
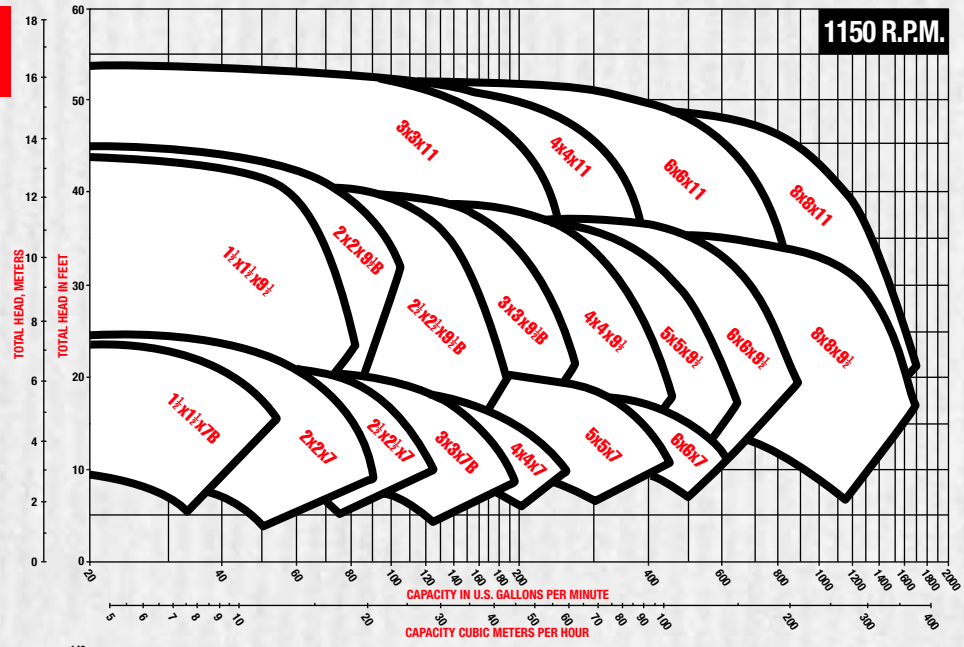

SERIES 80 - STANDARD SIZE PUMP

PERFORMANCE CURVES

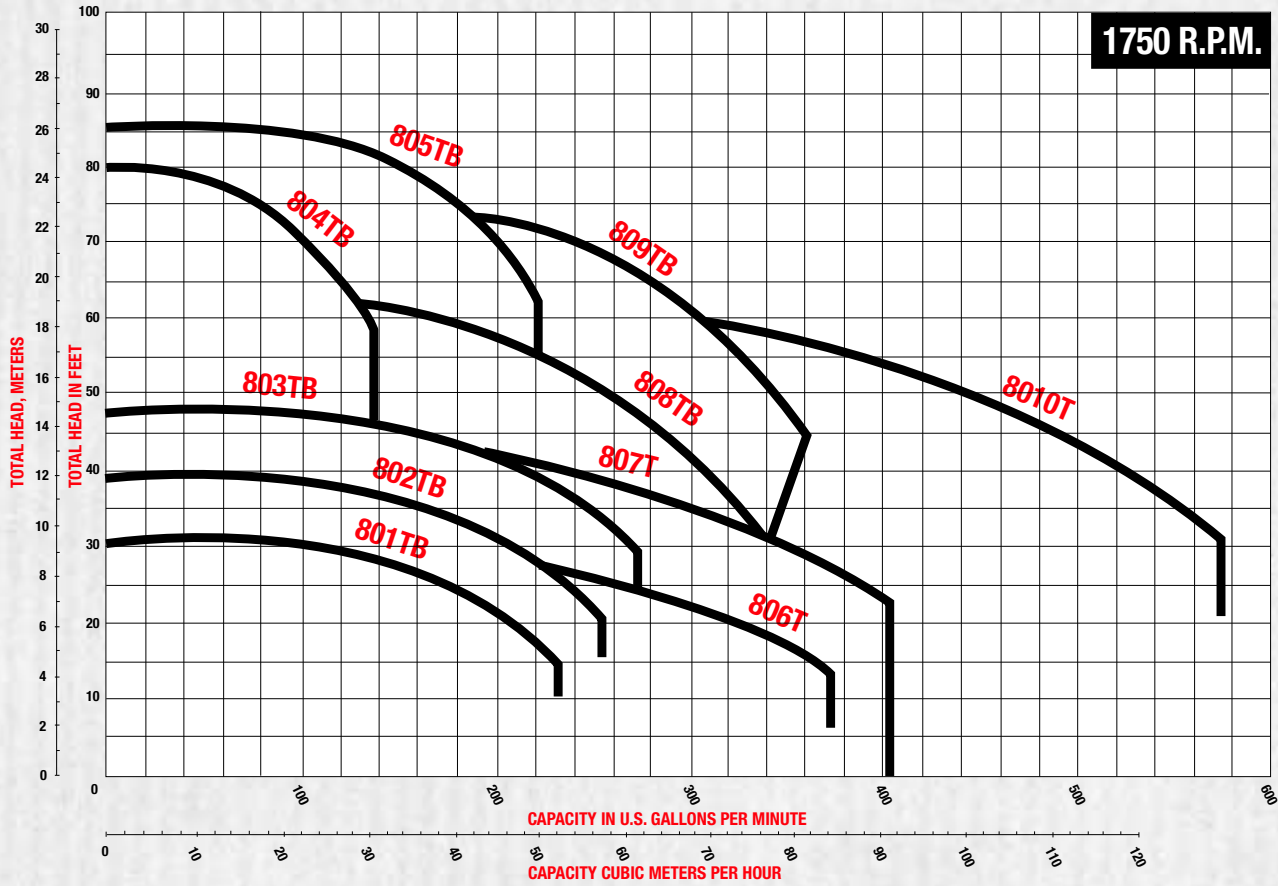

DIMENSIONS IN INCHES (mm)

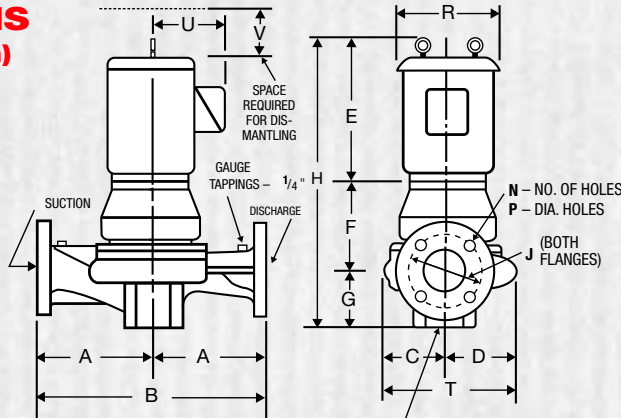

PUMP CONSTRUCTION:
BRONZE FITTED,
MECHANICAL SEAL

208-230/460 VOLT
3 PHASE, 60 HERTZ
OPEN DRIPPROOF
MOTORS. 1750 RPM

**MAXIMUM WORKING
PRESSURE 175 PSI (12 BAR)**

VOLUTE BASE RING TAPPED FOR
125# ANSI FLANGE - 2" FOR UNITS
801T THRU 805T; & 3" FOR UNITS
806T THRU 8010T

UNIT NO.	PUMP	MOTOR		A	B	C	D	E (MAX.)	F	G	H	125# ANSI			R	T	V	U
		H.P.	FR.									J	N	P				
801TB	3x3x7B	1.5	145JM	9 1/2	19	5 1/4	6 1/4	12 5/8	4 7/8	5 1/2	23	6	4	3/4	9 3/4	11 1/2	4 1/2	5 3/4
802TB		2		(241)	(483)	(133)	(159)	(321)	(124)	(140)	(584)				(152)	(114)		(146)
803TB		3		182JM	10	20	6	6 5/8	15 5/16	4 3/4	5 3/8				25 3/4	4 3/4		11 3/4
804TB	2x2x9 1/2 B	5	184JM	10 3/4	21 1/2	6 3/8	7 1/8	15 5/16	4 13/16	6	26 1/8	5 1/2	19	11 3/4	12 5/8	4 3/4	8 1/8	
805TB	2 1/2 x 2 1/2 x 9 1/2 B			10 3/4	21 1/2	6 3/8	7 1/8	15 5/16	4 13/16	6	26 1/8	5 1/2		11 3/4	12 5/8	4 3/4	8 1/8	
806T	4x4x7			10 1/2	21	5 1/2	6 3/4	12 5/8	5 1/8	6 3/8	24 1/8	7 1/2		8	9 3/4	12 1/4	5	5 3/4
807T	3x3x9 1/2 B	3	182JM	(267)	(533)	(140)	(171)	15 5/16	(130)	(162)	26 13/16	(191)	(203)	11 3/4	(311)	(127)	8 1/8	
808TB		5	184JM	11 1/2	23	6 3/8	7 1/2	(389)	4 13/16	6 1/8	26 1/4	6	4	(298)	14 1/8	4 1/2	(206)	
809TB		7.5	213JM	(292)	(584)	(168)	(191)	19 1/4	(122)	(156)	30 1/4	(152)	(102)	14	(359)	(114)	8 3/4	
8010T	4x4x9 1/2			12 1/2	25	7 1/4	8 1/2	(489)	5 1/8	7 1/8	31 1/2	7 1/2	8	(356)	15 3/4	5	(222)	

Dimensions subject to change without notice. Do not use for construction purposes.

MOTOR FRAME	DIMENSIONS IN INCHES (mm)																															
	A	B	C	D	MAX. E*	STD. SEAL - F	STUFF. BOX F	G	MAX. STD. - F H*	MAX. STUFF. BOX H*	125 #ANSI			250 #ANSI			MAX. R	T	MIN. V													
											J	N	P	J	N	P																
PUMP SIZE 6 x 6 x 7																																
182	14 (356)	28 (711)	6 1/2 (165)	8 1/2 (216)	15 5/16 (389)	6 1/16 (154)	9 1/4 (235)	8 1/8 (206)	29 1/2 (749)	32 11/16 (830)	9 1/2 (241)	8 (203)	7/8 (22)	10 5/8 (270)	12 (305)	7/8 (22)	11 3/4 (298)	15 (381)	5 1/4 (133)													
184					19 1/4 (489)				33 7/16 (849)	37 5/16 (947)							14 (356)															
213					24 1/8 (613)				42 3/16 (1072)	42 3/16 (1071)							17 (432)															
254					23 5/8 (600)	9 15/16 (252)	41 11/16 (1059)		41 11/16 (1059)	16 1/8 (410)																						
256					25 1/8 (638)					43 3/16 (1097)							43 3/16 (1097)			18 3/4 (476)												
284					26 (660)					44 1/16 (1119)							44 1/16 (1119)															
286																																
324																																
326																																
PUMP SIZE 1 1/2 x 1 1/2 x 9 1/2																																
143	9 1/2 (241)	19 (711)	5 7/8 (149)	6 1/4 (159)	11 5/8 (295)	4 11/16 (119)	7 13/16 (198)	4 1/2 (114)	20 7/8 (530)	24 (610)	3 7/8 (98)	4 (102)	5/8 (16)	4 1/2 (114)	4 (102)	7/8 (22)	9 3/4 (248)	12 1/8 (308)	4 (102)													
145					12 5/8 (321)				21 7/8 (556)	25 (635)							11 3/4 (298)															
182					15 5/16 (389)				24 1/2 (622)	27 5/8 (702)							13 3/4 (343)															
184					19 1/4 (489)	8 9/16 (217)	37 1/4 (946)		37 1/4 (946)	14 (356)																						
213					24 1/8 (613)					36 3/4 (933)							36 3/4 (933)			17 (432)												
254					23 5/8 (600)															16 1/8 (410)												
256																																
284																																
PUMP SIZE 2 x 2 x 9 1/2B																																
145	10 (254)	20 (508)	6 (152)	6 5/8 (168)	12 5/8 (321)	4 3/4 (121)	7 7/8 (200)	5 3/8 (137)	22 3/4 (578)	25 7/8 (657)	4 3/4 (121)	4 (102)	3/4 (19)	5 (127)	8 (203)	3/4 (19)	9 3/4 (248)	12 5/8 (321)	4 1/2 (114)													
182					15 5/16 (389)				25 7/16 (646)	28 9/16 (725)							11 3/4 (298)															
184					19 1/4 (489)				29 3/8 (746)	33 1/4 (845)							14 (356)															
213					24 1/8 (613)	38 1/8 (968)	38 1/8 (968)		17 (432)																							
254					23 5/8 (600)	37 5/8 (956)	37 5/8 (956)		16 1/8 (410)																							
256					25 1/8 (638)	39 1/8 (994)	39 1/8 (994)		18 3/4 (476)																							
284																																
PUMP SIZE 2 1/2 x 2 1/2 x 9 1/2B																																
145					10 3/4 (273)	21 1/2 (546)	6 3/4 (162)		7 1/8 (181)	12 5/8 (321)							4 13/16 (122)			7 15/16 (202)	6 (153)	23 1/2 (597)	26 5/8 (676)	5 1/2 (140)	4 (102)	3/8 (19)	5 7/8 (149)	8 (203)	7/8 (22)	9 3/4 (248)	13 1/2 (343)	4 3/4 (121)
182	15 5/16 (389)	26 1/8 (664)	29 1/4 (743)	11 3/4 (298)																												
184	19 1/4 (489)	30 1/8 (765)	34 (864)	14 (356)																												
213	24 1/8 (613)	38 7/8 (987)	38 7/8 (987)	17 (432)																												
254	23 5/8 (600)	38 3/8 (975)	38 3/8 (975)	16 1/8 (410)																												
256	25 1/8 (638)	39 7/8 (1013)	39 7/8 (1013)	18 3/4 (476)																												
284	26 (660)	40 3/4 (1035)	40 3/4 (1035)																													
324																																
326																																
PUMP SIZE 3 x 3 x 9 1/2B																																
184	11 1/2 (292)	23 (584)	6 5/8 (168)	7 1/2 (191)	15 3/8 (391)	4 13/16 (122)	7 15/16 (202)	6 1/8 (156)	26 1/4 (667)	29 3/8 (746)	6 (152)	4 (102)	3/4 (19)	6 5/8 (168)	8 (203)	7/8 (22)	11 3/4 (298)	14 1/8 (359)	4 1/2 (114)													
213					19 1/4 (489)				30 1/4 (768)	34 1/8 (867)							14 (356)															
254					24 1/8 (613)				39 (991)	39 (991)							17 (432)															
256					23 5/8 (600)	38 1/2 (978)	38 1/2 (978)		16 1/8 (410)																							
284					25 1/8 (638)	40 (1016)	40 (1016)		18 3/4 (476)																							
324					26 (660)	40 7/8 (1038)	40 7/8 (1038)																									
326																																
PUMP SIZE 4 x 4 x 9 1/2																																
184					12 1/2 (318)	25 (635)	7 1/4 (184)		8 1/2 (216)	15 5/16 (389)							5 1/8 (130)			8 1/4 (210)	7 1/8 (181)	27 9/16 (700)	30 11/16 (779)	7 1/2 (191)	8 (203)	3/4 (19)	7 7/8 (200)	8 (203)	7/8 (22)	11 3/4 (298)	15 3/4 (400)	5 (127)
213	19 1/4 (489)	9 (229)	31 1/2 (800)	35 3/8 (899)				14 (356)																								
254	24 1/8 (613)		40 1/4 (1022)	40 1/4 (1022)				17 (432)																								
256																																
PUMP SIZE 5 x 5 x 9 1/2																																
213	14 1/2 (368)	29 (737)	7 3/8 (187)	9 (229)	19 1/4 (489)	5 1/8 (130)	9 (229)	7 (178)	31 3/8 (797)	35 1/4 (895)	8 1/2 (216)	8 (203)	7/8 (22)	9 1/4 (235)	8 (203)	7/8 (22)	14 (356)	16 3/8 (416)	5 (127)													
215					24 1/8 (613)				9 (229)	40 1/8 (1019)							40 1/8 (1019)			17 (432)												
254																																
256																																
PUMP SIZE 6 x 6 x 9 1/2																																
213	16 3/4 (425)	33 1/2 (851)	8 1/4 (210)	10 (254)	19 1/4 (489)	5 3/8 (137)	9 1/4 (235)	8 3/4 (222)	33 3/8 (848)	37 1/4 (946)	9 1/2 (241)	8 (203)	7/8 (22)	10 5/8 (270)	12 (305)	7/8 (22)	14 (356)	18 1/4 (464)	5 (127)													
215					24 1/8 (613)				9 1/4 (235)	42 1/8 (1070)							42 1/8 (1070)			17 (432)												
254					23 5/8 (600)					41 5/8 (1057)							41 5/8 (1057)			16 1/8 (410)												
284																																
PUMP SIZE 8 x 8 x 9 1/2																																
254	18 (457)	36 (914)	8 1/2 (216)	11 (279)	24 1/8 (613)	10 1/4 (260)	10 1/4 (260)	10 1/4 (260)	44 5/8 (1133)	44 5/8 (1133)	11 3/4 (298)	8 (203)	7/8 (22)	13 (330)	12 (305)	1 (25)	17 (432)	19 1/2 (495)	6 1/4 (159)													
256					23 5/8 (600)				10 1/4 (260)	44 1/8 (1121)							44 1/8 (1121)			16 1/8 (410)												
284					25 1/8 (638)				10 1/4 (260)	45 5/8 (1159)							45 5/8 (1159)			18 3/4 (476)												
324					26 (660)	46 1/2 (1181)	46 1/2 (1181)																									
326																																

*For 1 phase motors add 1" maximum to dimensions E & H.

Dimensions subject to change without notice.
Do not use for construction purposes.

MOTOR FRAME	DIMENSIONS IN INCHES (mm)																			
	A	B	C	D	MAX. E*	STD. SEAL, -F F	80-S. D, -PF F	G	MAX. STD SEAL, -F H*	MAX. 80-S. -D, -PF H*	125 #ANSI			250 #ANSI			R	MAX. S**	T	MIN. V
											J	N	P	J	N	P				
PUMP SIZE 3 x 3 x 11																				
213	12 (305)	24 (610)	6 ¹⁵ / ₁₆ (176)	7 ⁵ / ₈ (194)	19 ¹ / ₄ (489)	4 ³ / ₁₆ (106)	7 ³ / ₁₆ (183)	6 ³ / ₄ (171)	30 ³ / ₁₆ (767)	33 ³ / ₁₆ (843)	6 (152)	4 (102)	3 ¹ / ₄ (91)	6 ⁵ / ₈ (168)	8 (203)	7 ¹ / ₈ (22)	14 (356)	-	14 ⁹ / ₁₆ (370)	5 ³ / ₄ (146)
215					24 ¹ / ₈ (613)	38 ³ / ₈ (975)	38 ³ / ₈ (975)		17 (432)											
254					23 ⁵ / ₈ (600)	37 ⁷ / ₈ (962)	37 ⁷ / ₈ (962)		16 ¹ / ₈ (410)											
256					25 ¹ / ₈ (638)	39 ³ / ₈ (1000)	39 ³ / ₈ (1000)		16 ¹ / ₈ (410)											
284					26 (660)	40 ¹ / ₄ (1022)	40 ¹ / ₄ (1022)		18 ³ / ₄ (476)											
286																				
324																				
326																				
PUMP SIZE 4 x 4 x 11																				
213	13 (330)	26 (660)	7 ⁹ / ₁₆ (192)	8 ⁹ / ₁₆ (217)	19 ¹ / ₄ (489)	4 ³ / ₈ (111)	7 ³ / ₈ (187)	7 ¹ / ₂ (191)	32 ¹ / ₈ (816)	35 ¹ / ₈ (892)	7 ¹ / ₂ (191)	8 (203)	3 ¹ / ₄ (91)	7 ⁷ / ₈ (200)	8 (203)	7 ¹ / ₈ (22)	14 (356)	-	16 ¹ / ₈ (410)	5 ¹ / ₄ (133)
215					24 ¹ / ₈ (613)	39 ⁵ / ₁₆ (999)	39 ⁵ / ₁₆ (999)		17 (432)											
254																				
256																				
PUMP SIZE 6 x 6 x 11																				
213	16 (406)	32 (813)	8 ³ / ₈ (213)	9 ³ / ₄ (248)	19 ¹ / ₄ (489)	-	7 ⁹ / ₁₆ (192)	8 ³ / ₄ (222)	-	35 ⁹ / ₁₆ (903)	9 ¹ / ₂ (241)	8 (203)	7 ¹ / ₈ (22)	10 ⁵ / ₈ (270)	12 (305)	7 ¹ / ₈ (22)	14 (356)	-	18 ¹ / ₈ (460)	5 ⁵ / ₁₆ (135)
215					24 ¹ / ₈ (613)	40 ¹¹ / ₁₆ (1033)	40 ¹¹ / ₁₆ (1033)		17 (432)											
254					23 ⁵ / ₈ (600)	40 ³ / ₁₆ (1021)	40 ³ / ₁₆ (1021)		16 ¹ / ₈ (410)											
256					25 ¹ / ₈ (638)	41 ¹¹ / ₁₆ (1059)	41 ¹¹ / ₁₆ (1059)		16 ¹ / ₈ (410)											
284					26 (660)	42 ⁹ / ₁₆ (1081)	42 ⁹ / ₁₆ (1081)		18 ³ / ₄ (476)											
286																				
324																				
PUMP SIZE 8 x 8 x 11																				
254	18 (457)	36 (914)	9 (229)	11 ³ / ₈ (289)	24 ¹ / ₈ (613)	8 ¹ / ₈ (206)	8 ¹ / ₈ (206)	10 ¹ / ₄ (260)	42 ¹ / ₂ (1080)	42 ¹ / ₂ (1080)	11 ³ / ₄ (298)	8 (203)	7 ¹ / ₈ (22)	13 (330)	12 (305)	7 ¹ / ₈ (22)	17 (432)	-	20 ³ / ₈ (518)	5 ³ / ₄ (146)
256					23 ⁵ / ₈ (600)				42 (1067)	42 (1067)							16 ¹ / ₈ (410)			
284					25 ¹ / ₈ (638)				43 ¹ / ₂ (1105)	43 ¹ / ₂ (1105)							16 ¹ / ₈ (410)			
286					26 (660)				44 ³ / ₈ (1127)	44 ³ / ₈ (1127)							18 ³ / ₄ (476)			
324																				
326																				

*For 1 phase motors add 1" maximum to dimensions E & H.

**For TEFC Motors add S dimensions to dimensions E & H.

Dimensions subject to change without notice.
Do not use for construction purposes.

TYPICAL SPECIFICATIONS FOR BELL & GOSSETT SERIES 80 IN-LINE PUMPS

Furnished and installed with capacities as shown on plans. Pumps shall be in-line type, close-coupled single stage design, for installation in vertical or horizontal position, and capable of being serviced without disturbing piping connections.

Pump casing shall be of Class 30 cast iron. The impeller shall be of cast bronze, closed type, balanced to ANSI/Hi Grade G6.3, keyed to the shaft and secured by locking capscrew.

The liquid cavity shall be sealed off at the motor shaft by an internally-flushed mechanical seal with ceramic seal seat and carbon seal ring, suitable for continuous operation at 225°F.

A bronze shaft sleeve shall completely cover the wetted area under the seal.

Pumps shall be rated for minimum of 175 psi working pressure (optional 250 psi and 300 psi working pressure). The pump case shall have gauge tapings at the suction and discharge nozzles and will include drain ports.

Motor shall meet NEMA specifications and shall be the size, voltage and enclosure called for on the plans. It shall have heavy-duty, grease lubricated ball bearings, completely adequate for the maximum load for which the pump is designed.

Each pump shall be factory tested per Hydraulic Institute standards. It shall then be thoroughly cleaned and painted with at least one coat of high-grade machinery enamel prior to shipment.

Pumps shall be Series 80 as manufactured by ITT Bell & Gossett or equal.



Bell & Gossett

USA
Bell & Gossett
8200 N. Austin Avenue
Morton Grove, IL 60053
Phone: (847) 966-3700
Facsimile: (847) 966-9052
<http://www.bellgossett.com>

INTL.
Bell & Gossett / Export Dept.
8200 N. Austin Avenue
Morton Grove, IL 60053
Phone: (847) 966-3700
Facsimile: (847) 966-8366
<http://www.bellgossett.com>

CANADA
Fluid Products Canada
55 Royal Road
Guelph, Ontario,
N1H 1T1, Canada
Phone: (519) 821-1900