



Model EAS Enhanced Air Separator

REMOVES ENTRAINED AIR

- Increases heat transfer and comfort
- Reduces noise in the system

SUPREME FIRST PASS EFFICIENCY

- Removes over 99% of air, including micro-bubbles

PREVENTS CALL BACKS

HIGH FLOW RATES

- Up to 55% more than the competition

FOUR SIZES AVAILABLE

- For residential and commercial applications

EASY TO INSTALL

- No minimum pipe run required
- Straight or angle installation
- Compatible with diaphragm or compression tanks

REMOVABLE 3/4" HIGH CAPACITY AIR VENT



HOW IT WORKS:

1. As system fluid enters through the inlet, (either straight or angle) the diffuser distributes flow evenly across the stainless steel, wire brush-like medium.
2. Air bubbles, even micro air bubbles, stick to the brush filaments.
3. Trapped air rises above the diffuser, through a baffle (not pictured), where the air is then released through an opening on top.
4. Deaerated water then goes back into the system.

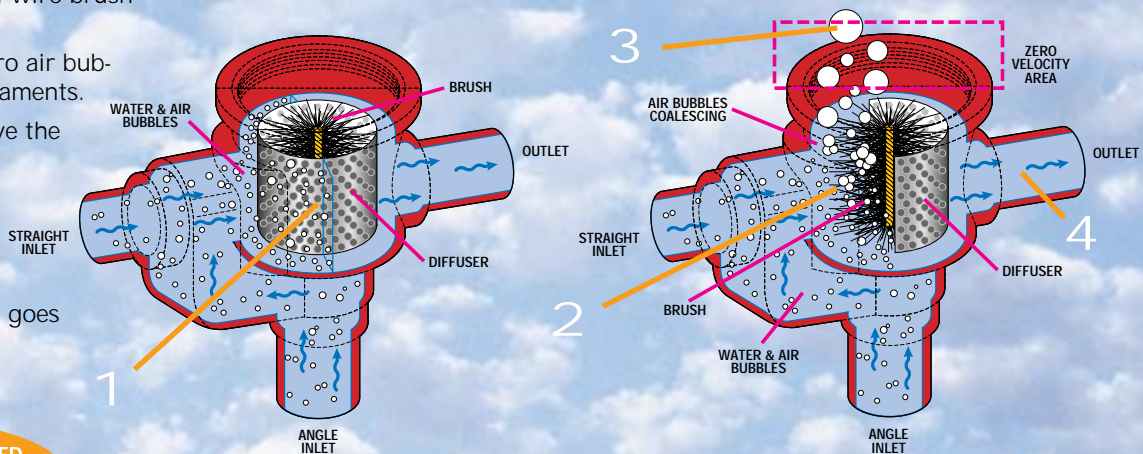

DESIGNED & MANUFACTURED
IN THE U.S.A. FOR AMERICAN
HEATING SYSTEMS

Bell & Gossett Model EAS Enhanced Air Separator

Description

Bell & Gossett's Model EAS Enhanced Air Separator is a patented, innovative design in air separators. It has been engineered to remove entrained air from hydronic heating and cooling systems providing far superior air removal compared with other devices available today. The EAS is ideal for residential, institutional and light commercial applications.

Operating Data

Maximum working pressure 150 psi (10.3 bar)
 Maximum operating temperature 250°F (121°C)

Materials of Construction

Body & Cap Cast Iron
 Internals Stainless Steel
 3/4" Large Capacity Air Vent Brass Body, Nonferrous Internals

Warranty

The Model EAS Enhanced Air Separator and 3/4" Large Capacity Air Vent come with Bell & Gossett's standard warranty of 18 months from the date of manufacture, or one year from date of installation, against failure as a result of defects in materials and workmanship.

Dimensions & Weights

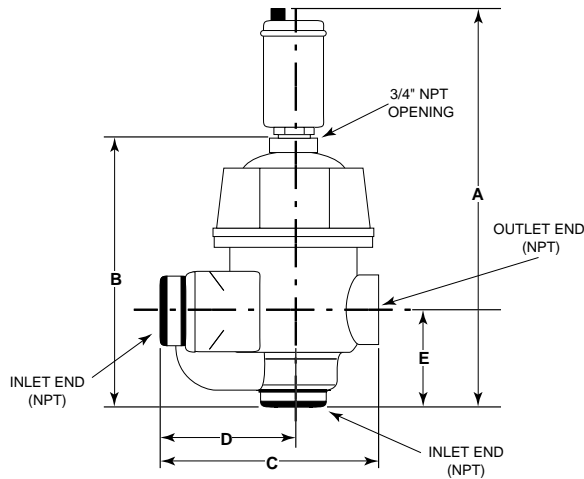

MODEL NO.	PART NO.	MAX. FLOW (GPM)	SIZE INCHES NPT	DIMENSIONS - INCHES (MM)					APPROX. SHPG. WGT. LBS. (Kg)
				A	B	C	D	E	
EAS-1	112105	35	1	12 ³ / ₁₆ (310)	6 ⁷ / ₈ (175)	6 ⁷ / ₁₆ (164)	3 ¹⁵ / ₁₆ (100)	3 (76)	8.8 (4)
EAS-1 ¹ / ₄	112106	35	1 ¹ / ₄	12 ³ / ₁₆ (310)	6 ⁷ / ₈ (175)	6 ⁷ / ₁₆ (164)	3 ¹⁵ / ₁₆ (100)	3 (76)	8.4 (3.8)
EAS-1 ¹ / ₂	112107	45	1 ¹ / ₂	15 ³ / ₄ (400)	11 ³ / ₈ (289)	8 ⁵ / ₈ (219)	4 ⁷ / ₈ (124)	4 ¹ / ₄ (108)	15.5 (7)
EAS-2	112108	70	2	17 ¹ / ₂ (445)	11 ³ / ₈ (289)	8 ⁵ / ₈ (219)	4 ⁷ / ₈ (124)	4 ¹ / ₄ (108)	15.25 (6.9)

EAS-1 or EAS-1 ¹/₄ MAX. WIDTH 4 ¹/₁₆" (103mm)
 EAS-1 ¹/₂ or EAS-2 MAX. WIDTH 5 ³/₄" (146mm)



Typical Applications

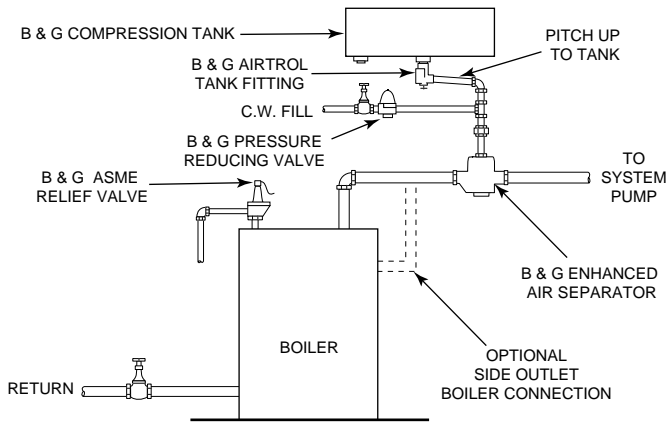

Model EAS with Conventional Compression Tank

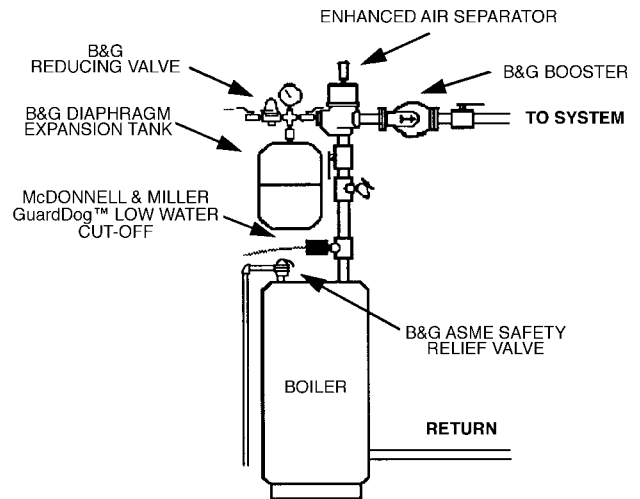

Model EAS with Pressurized Expansion Tank

ITT Industries

Bell & Gossett

8200 N. Austin Avenue
 Morton Grove, IL 60053
 Phone: 847/966-3700
 FAX: 847/966-9052
<http://fhs.ittind.com>