

## Series 90 In Line Centrifugal Pump

INSTRUCTIONS FOR:

INSTALLATION  
OPERATION  
SAFETY  
SERVICE

---

**INSTALLER:** PLEASE LEAVE THIS MANUAL FOR THE OWNER'S USE.

---

### DESCRIPTION

The Series 90 In-Line Mounted Centrifugal Pump is a close coupled, space saving, low maintenance pump capable of performing a wide range of fluid applications. The Back Pull-Out feature allows the pump to be serviced without disturbing system piping. The Series 90 pumps are available for pipe sizes from 1" to 2".

### PUMP APPLICATION

Series 90 Pumps may be used for hydronic heating & cooling, domestic hot water, cooling towers, machinery cooling, pressure boosting, industrial fluid transfer, refrigeration & heat exchanger circulation. Bell & Gossett recommends that bronze constructed pumps be used for pumping potable water. For other applications contact your local B&G Representative.

### OPERATIONAL LIMITS

B&G Series 90 Pumps are designed to pump liquids compatible with their iron or bronze body construction. Unless special provisions have been made by ITT Bell & Gossett, the operational limits for Series 90 Pumps are listed below.

**Do not exceed these values.**

Maximum Working Pressure: 175 psi

Mechanical Seal: Buna – PH limitations 7-9;  
Temperature Range –40 to +225°F

EPT – PH Limitations 7-9  
Temperature Range –40 to +250°F

## SAFETY INSTRUCTIONS



This safety alert symbol will be used in this manual and on the pump instructions decal to draw attention to safety related instructions. When used, the safety alert symbol means **ATTENTION! BECOME ALERT! YOUR SAFETY IS INVOLVED! FAILURE TO FOLLOW THE INSTRUCTIONS MAY RESULT IN A SAFETY HAZARD.**

Your Series 90 Pump should have the following warning labels affixed to the pump in the approximate positions shown. If these warnings are missing or illegible, contact your Bell & Gossett Representative for a replacement.

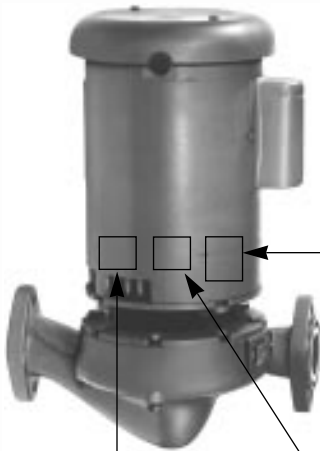

## SAFETY REQUIREMENTS

### ELECTRICAL SAFETY



#### **WARNING: ELECTRICAL SHOCK HAZARD.**

Electrical connections to be made by a qualified electrician in accordance with all applicable codes, ordinances and good practices. Failure to follow these instructions could result in serious personal injury, death and/or property damage.



#### **WARNING: ELECTRICAL OVERLOAD HAZARD.**

Three phase motors must have properly sized heaters to provide overload and under voltage protection. Single phase motors have built-in overload protectors. Failure to follow these instructions could result in serious personal injury, death and/or property damage.

### THERMAL SAFETY



#### **WARNING: EXTREME TEMPERATURE HAZARD.**

If the pump, motor, or piping are operating at extremely high or low temperature, guarding or insulation is required. Failure to follow these instructions could result in serious personal injury, death and/or property damage.



#### **WARNING: HOT WATER HAZARD.**

When disassembling a gasketed joint, always use a new gasket upon reassembly. **NEVER RE-USE OLD GASKETS.** Failure to follow these instructions could result in serious personal injury, death and/or property damage.

### MECHANICAL SAFETY



#### **WARNING: UNEXPECTED START-UP HAZARD.**

Disconnect and lockout power before servicing. Failure to follow these instructions could result in serious personal injury, death and/or property damage.



#### **WARNING: EXCESSIVE SYSTEM PRESSURE HAZARD.**

The maximum working pressure of the pump is listed on the nameplate – **DO NOT EXCEED THIS PRESSURE.** Failure to follow these instructions could result in serious personal injury, death and/or property damage.



#### **WARNING: EXCESSIVE PRESSURE HAZARD –**

**VOLUMETRIC EXPANSION.** The heating of water and other fluids causes volumetric expansion. The associated forces may cause failure of system components and release high temperature fluids. This can be prevented by installing properly sized and located compression tanks and pressure relief valves. Failure to follow these instructions could result in serious personal injury, death and/or property damage.

## PUMP INSTALLATION

### PUMP SUPPORT AND LOCATION

The Bell & Gossett Series 90 pump should be installed where there will be sufficient room for future inspection, maintenance and service. It is highly recommended that service valves (shut-off) also be installed on each side of the pump to facilitate servicing or replacing without draining the system. Special precautions should be taken to avoid sound and vibration transmission. If the pump is to be located near a noise sensitive area, consult a sound specialist.

If it is required to lift the entire pump, do so with slings placed around the pump assembly as shown.



Install the suction and discharge flanges on the pipe ends using teflon tape sealer or high quality thread sealant. Minimize strain on the pump by supporting the suction and discharge piping with pipe hangers near the pump. Line up the vertical and horizontal piping so that the bolt-holes in both the pump and pipe flanges are aligned. **DO NOT ATTEMPT TO SPRING THE SUCTION OR DISCHARGE LINES INTO POSITION. THIS MAY RESULT IN UNWANTED STRESS IN THE PUMP BODY, FLANGE CONNECTIONS AND/OR PIPING.** The code for pressure piping, ANSI B31.1, lists types of supports available for various applications.

Ordinary wire or band hangers are not adequate to maintain alignment. It is very important to provide strong, rigid support for the suction and discharge lines.

New Bell & Gossett flange gaskets must be installed between the flanges of the pump body and suction and discharge pipes. The gaskets should be clean and grease-free; old gaskets should never be reused. Suitable fasteners for this connection are supplied in the B&G fastener pack. Apply a torque of 8-11 ft. lbs. to each of the flange bolts. Both the suction and discharge flanges must be torqued to the same level.



#### **WARNING: HOT WATER LEAKAGE HAZARD.**

Make certain that the flange bolts have been adequately torqued. Failure to follow these instructions could result in serious personal injury and/or property damage.

**IMPORTANT:** In closed systems, do not install and operate Bell & Gossett pumps, 3D valves, suction diffusers, etc., without properly sized safety and control devices. Such devices include properly sized and located pressure relief valves, compression tanks and pressure, temperature, and flow controls. If the system is not equipped with these devices, consult the responsible engineer or architect before operating.

### MODE OF DISCHARGE

B&G Series 90 In-Line pumps may be installed to discharge vertically or horizontally. **THE ARROW ON THE PUMP BODY MUST POINT IN THE DIRECTION OF THE FLOW.**

The pump may be installed with the motor vertical or horizontal. Do not install with the motor below the pump body.

### SYSTEM PIPING

Always install a section of straight pipe between the suction side of the pump and the first elbow. The length of this pipe should be equal to five times the diameter of the suction pipe size. This reduces turbulence of the suction by straightening the liquid flow path prior to pump entry.

Air must be kept out of the system. On an open system always place the end of the suction pipe at least three feet (3') below the surface of the water in the suction well to prevent air from being drawn into the pump. Avoid air pockets in the suction line and ensure that each section of the suction pipe is absolutely air tight.

If high temperature variation is anticipated, expansion fittings should be installed such that they reduce pump strain.

## PIPING SCHEMATIC

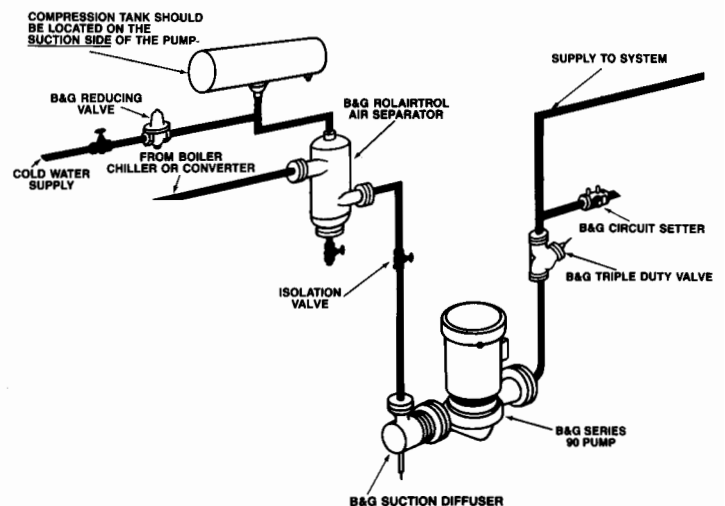

## WIRING INSTRUCTIONS



### **WARNING: ELECTRICAL SHOCK HAZARD.**

Disconnect and lockout the power before making electrical connections. Failure to follow these instructions could result in serious personal injury, death and/or property damage.

Remove the screws securing the conduit box cover (wiring compartment) and lift off the cover. Attach the appropriate size connector to the hole in the side of the conduit box.



### **WARNING: ELECTRICAL OVERLOAD HAZARD**

Three phase motors must have properly sized heaters to provide overload and under voltage protection. Single phase motors have built-in overload protectors. Failure to follow these instructions could result in serious personal injury or death.



### **WARNING: ELECTRICAL SHOCK HAZARD.**

Be certain that all connections are secure and the conduit box cover is closed before electrical power is connected. Failure to follow these instructions could result in serious personal injury or death.

## OPERATIONAL INSTRUCTIONS

### SYSTEM PREPARATION

Prior to pump start up, closed heating and cooling systems should be flushed and drained with clean water. The system should then be filled with clean water having a PH between 7 and 9.

### LUBRICATION

Series 90 Pumps with 5 HP and smaller motors are permanently lubricated. Pumps with 7<sup>1</sup>/<sub>2</sub>, 10 and 15 HP motors are furnished with grease fittings and should be lubricated in accordance with the manufacturer's nameplate instructions. For future lubrication, Bell & Gossett supplies a high quality lubricant specifically for this purpose which can be purchased from any B&G representative (Part No. L23401).

### ROTATION

Pump rotation is clockwise when viewed from the back of the motor. An arrow is provided to show the rotational direction.

### PRIMING AND STARTING



### **CAUTION: SEAL DAMAGE HAZARD.**

Do not run the pump dry – seal damage may occur. Failure to follow these instructions could result in moderate personal injury and/or property damage.

Before starting, the Series 90 pump must first be filled with water. Manual priming may be necessary if the system does not fill the pump body automatically. Vent plugs are provided on the pump body to vent the air.



### **WARNING: HOT WATER LEAKAGE HAZARD.**

Pressurize the pump body slowly while checking for leaks at all joints with gaskets. Failure to follow these instructions could result in serious personal injury and/or property damage.

The pump should be started with the discharge valve closed and the suction valve fully open. After the pump is at operating speed, the discharge valve should be opened gradually

## SERVICE INSTRUCTIONS

### GENERAL INSTRUCTIONS

1. Keep motor properly lubricated if required.
2. If the pump is to be exposed to freezing temperatures, drain the pump.

### PERIODIC INSPECTION

Inspect the pump regularly for leaking seals, worn gaskets, and loose or damaged components. Replace or repair as required.

## REPLACING THE SEAL



### **WARNING: ELECTRICAL SHOCK HAZARD.**

Disconnect and lockout the power before servicing. Failure to follow these instructions could result in serious personal injury or death.

The electrical supply must be disconnected and locked out of service. Loosen the conduit box cover screws and remove the cover. Disconnect conduit and wiring.



### **WARNING: UNEXPECTED START-UP HAZARD.**

Disconnect and lockout power before servicing. Failure to follow these instructions could result in serious personal injury, death and/or property damage.

Close the valves on the suction and discharge sides of the pump (if no valves have been installed, it will be necessary to drain the system).



### **CAUTION: EXTREME TEMPERATURE HAZARD.**

Allow the pump temperature to reach an acceptable level before proceeding. Open the drain valve and do not proceed until the liquid has completely drained. If the liquid does not stop flowing from the drain valve, then the isolation valves are not sealing and should be repaired before continuing. After the liquid has stopped flowing, leave the drain valve open and continue. Remove the drain plug located on the bottom of the pump volute. Do not reinstall this plug or close the drain valve until the reassembly is complete. Failure to follow these instructions could result in moderate personal injury and/or property damage.

Loosen the volute capscrews but do not remove them. Shift the pump position slightly to allow the pressurized water to escape.



**WARNING: EXCESSIVE PRESSURE HAZARD.**

Make certain that the internal pressure is relieved before continuing. Failure to follow these instructions could result in serious personal injury and/or property damage.

Remove the volute capscrews and remove the pump assembly from the volute.

**DETERMINE THE SEAL SIZE**

Cut away diagrams have been provided to illustrate the components of the Series 90 pump assemblies. The primary feature distinguishing between the A and AA type pumps is size. Measure the diameter of the shaft sleeve to determine nominal seal size. Series 90 pumps have three nominal seal sizes: 1/2", 3/4" & 1 1/4". Most components of the A and AA pump seals are similar (but not interchangeable). All Series 90 seals, except the 1 1/4", require a spring retainer as part of the seal assembly. Refer to these diagrams whenever seal replacement becomes necessary.

**PUMP BODY DIAGRAM – A Size**

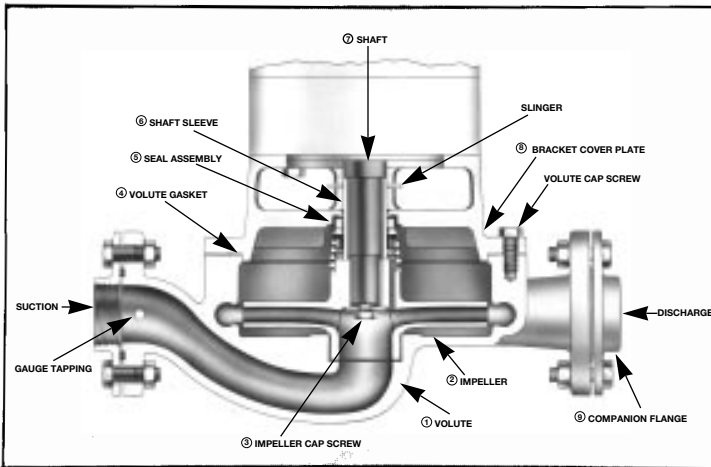

**PUMP BODY DIAGRAM – AA Size**

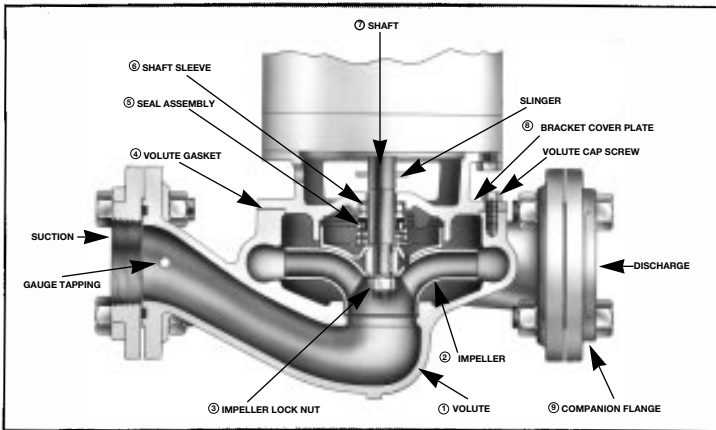

**REPLACEMENT PROCEDURE**

With the motor assembly removed from the system, use the following instructions to facilitate the replacement.

1. Use a strap wrench or rag to prevent the impeller from turning with one hand and loosen the impeller nut with the other.
2. Lift the spring retainer (not found in the 1 1/4" seal assembly) and the seal spring from the shaft. Remove the compression ring from the seal collar by inserting a small screwdriver underneath the ring and carefully applying an upward force.

**NOTE:** Bell and Gossett seal assemblies consist of a stationary seal insert assembly and a rotating seal assembly. Each of these components must be replaced when replacing the mechanical seal. NEVER REPLACE INDIVIDUAL COMPONENTS SEPERATELY.

3. Using a clean, lint free rag, remove any debris that may have accumulated in the seal recess.
4. For the 1/2" & 3/4" seals, place the new retainer in the face plate seal recess. Set the thin seat gasket in the recess and set the seat insert atop the gasket. A ceramic insert has a top side and bottom side. The bottom is identifiable by its slightly recessed grooves. These grooves should face downward toward the rubber gasket.

For the 1 1/4" seals, set the seal insert into the elastomeric seat cup. Lubricate the seat cup with soapy water and set it into the face plate recess.

5. Lubricate the rubber seal collar with soapy water. The entire rotating seal assembly, which includes a seal ring, bellows and seal housing, is to be pushed onto the shaft as one unit. Do not attempt to assemble the seal by placing the components on the shaft individually. The notches in the collar should be aligned with the recesses found on each side of the carbon ring.
6. Press the seal housing tightly against the upper end of the rubber collar. A screwdriver can be used at several points along its periphery to provide a tight and even fit. Press with the screwdriver – do not tap. Tapping on the seal may break the ceramic or carbon insert.
7. Place the seal spring on the shaft and then the spring retainer (except for the 1 1/4" seal). Next, place the impeller and lock washer on the shaft. Thread the impeller nut onto the shaft and tighten according to: 3/8" nut to 8-12 ft. lbs. 7/16" nut to 17-22 ft. lbs. & 3/8" capscrews to 10-14 ft. lbs. Do not overtighten.



**WARNING: HOT WATER HAZARD.**





When disassembling a gasketed joint, always use a new gasket upon reassembly. NEVER RE-USE OLD GASKETS. Failure to follow these instructions could result in serious personal injury, death and/or property damage.

(CONTINUED ON NEXT PAGE)

**SEAL REPLACEMENT (continued)**

- 8. Clean the pump body of excess debris. Place a new gasket in the recess of the pump body; ensure that it sits flush against the gasket surface.
- 9. Replace the motor assembly by inserting the impeller in the pump body and evenly tighten the eight cap screws. Refer to the TORQUE CHART below.

- 10. Refer to the WIRING INSTRUCTIONS section in this manual to properly configure all electrical connections.
- 11. Follow the OPERATIONAL INSTRUCTIONS in this manual to 1) check the PH of the system water, 2) to check the rotation of the pump and 3) to pressurize the system prior to starting.

Capscrew Type	Head Marking	CAPSCREW TORQUE (FOOT-POUND)								
		Capscrew Diameter								
		1/4	5/16	3/8	7/16	1/2	5/8	3/4	7/8	1
SAE Grade 2		6	13	25	38	60	120	190	210	300
Brass Stainless Steel	 or 	4	10	17	27	42	83	130	200	300
SAE Grade 5		10	20	35	60	90	180	325	525	800

**DEALER SERVICING**

YOUR BELL & GOSSETT REPRESENTATIVE IS ...

If your pump requires further repair, contact your local B&G Representative. Having the following information at hand will facilitate your representative's ability to assist you:

- 1. Complete data from nameplate.
- 2. Suction and discharge pipe pressure gauge readings.
- 3. Ampere draw of motor.
- 4. A sketch of the pumping system (include pipes, valves, etc.)

For further information, contact ITT Bell & Gossett, 8200 N. Austin Avenue, Morton Grove, IL 60053, Phone (847) 966-3700 – Facsimile (847) 966-9052.